

FILE

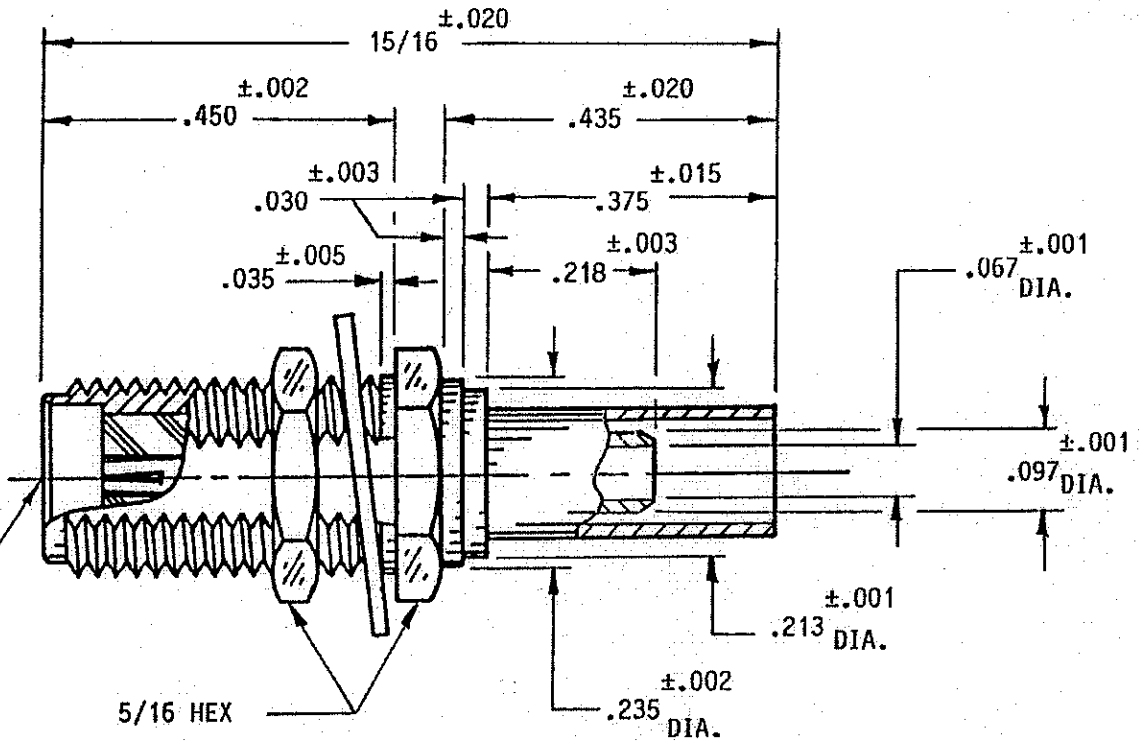

INTERFACE CONFORMS TO MIL-C-39012 SMA SERIES

** USE .128 HEX CRIMP DIE FOR CRIMPING

NOTES:

MATERIAL:

1. BODY & NUT = STAINLESS STEEL PER ASTM-A-582, TYPE 303.
2. CONTACT = BERYLLIUM COPPER PER QQ-C-530.
3. INSULATOR = TEFLON TFE PER ASTM-D-1710.
4. LOCKWASHER = PHOSPHOR BRONZE PER QQ-B-750.
5. CRIMP SLEEVE = SEAMLESS COPPER TUBE PER WW-T-799 TEMPER DEAD SOFT PER ASTM-B-188.

FINISHES:

1. BODY & NUT = GOLD PLATE PER MIL-G-45204 TYPE II, CLASS O, GRADE C OVER STRESS FREE NICKEL PER QQ-N-290.
2. LOCKWASHER & CRIMP SLEEVE = GOLD PLATE PER MIL-G-45204 TYPE II, CLASS O, GRADE C OVER COPPER STRIKE PER MIL-C-14550.
3. CONTACT = GOLD PLATE PER MIL-G-45204 TYPE II, CLASS I, GRADE C OVER STRESS FREE NICKEL PER QQ-N-290.

PROPRIETARY INFORMATION
NOT TO BE RELEASED
WITHOUT WRITTEN PERMISSION
FROM AN AUTHORIZED
REPRESENTATIVE OF
APPLIED ENGINEERING PRODUCTS.

SMA STRAIGHT BULKHEAD
JACK FOR USE WITH RG174,
179,316,M17/113,119,&173
FLEXIBLE CABLE

APPLIED ENGINEERING PRODUCTS
104 John W. Murphy Drive, P.O. Box 510
New Haven, CT 06513

CODE IDENT. **19505**

9030-1023-003