

Description

The electronic circuit breaker ESS30-S with physical isolation is the globally unique electronic overcurrent protection for DC 24 V applications as a “low energy breaker”. For the use in decentralised and centralised power supply units, it meets the requirements to DIN EN 60934, to UL1077 as a Supplementary Protector and to UL 1310 as “Class2 power unit” (NEC class2). The compact device can be plugged into the terminal blocks 17plus and 18plus and into the SVS power distribution systems and ensures quick and easy installation.

The ESS30-S is only 12.5 mm wide and selectively protects all DC 24 V load circuits. This is achieved by a combination of active electronic current limitation in the event of a short circuit and overload disconnection at typically 1.2 times rated current. DC 24 V switch-mode power supplies are widely used in automation today. In the event of an overload, however, they turn down the output voltage which is intended to power all connected loads. So if there is a failure in a single load of the system, the supply voltage will break down also in all other load circuits. Not only does this frequently cause undefined fault conditions, but it can even lead to machine stoppages or system downtimes.

The max. possible overcurrent is limited to typically 1.2 times rated current (see table 1). Switching capacitive loads up to 40,000 µF is possible without any problems. For adjustment to the load conditions the current rating can be selected in fixed values from 0.5 A to 10A and adjustable versions 1A/2A or 3A/6A are also available. Visual status indication is by means of a multicoloured LED and by integral signal outputs. The manual ON/OFF switch on the device itself allows start-up of certain individual load circuits and reset after disconnection on grounds of overcurrent.



Features

- Plug-in mounting on power distribution modules 17plus,18plus and SVSxx
- Physical isolation in the event of a failure
- Active linear current limitation
- Capacitive loads up to 40,000 µF
- Fixed current ratings 0.5 A...10 A (0.5A...3.6A NEC Class 2)
- 2 steps (1A/2A or 3A/6A) can be adjusted on the device by means of a switch
- Approvals: UL, NEC Class 2, VDE

Your Benefits

- Inventory costs are cut, because one model covers two current ratings
- Flexibility is enhanced through plug-in design and ease of current rating adjustment
- Cost-savings because the breakers up to 3.6A approved to UL12310 (NEC Class 2) replace the previously used expensive switch mode power supplies
- Saves energy costs through 1/3 lower power loss compared to competitive solutions.
- Increases system availability through clear failure detection and signalling

Preferred types – for more details on all configurations please see order numbering code

Preferred types are E-T-A products most frequently used by E-T-A customers. We manufacture E-T-A preferred types in particularly high

volumes. Our preferred types are supplied at shorter lead times than non-standard versions.

Preferred types	Preferred ratings (A)											
	0.5	1	2	3.6	3	4	6	8	10	2 (CL2)	3 (CL2)	3.6 (CL2)
ESS30-S003-DC24V	x	x	x		x	x	x	x	x			x

Approvals



Information online

For access to the latest documents please follow: www.e-t-a.de/e353

Compliances



Technical data ($T_{amb} = 25\text{ °C}$, $U_B = DC\ 24\ V$)

For further details please see: www.e-t-a.de/ti_e

Operating data

Operating voltage U_B	DC 24 V (18...30 V)
Current ratings I_N	fixed ratings: 0.5 A; 1 A; 2 A; 2 A CL2; 3 A; 3 A CL2; 3,6 A; 3,6 CL2 4 A; 6 A; 8 A; 10 A; Adjustable current ratings: 1 A/2 A; 3 A/6 A
Standby current I_0	in ON condition: typically 4 mA with adjustable versions typically 5.5 mA
Trip current (bimetal)	typically 0.4 A (only under fault condition, till physical isolation)
Visual status indication	<ul style="list-style-type: none"> ● multicoloured LED: <ul style="list-style-type: none"> green: <ul style="list-style-type: none"> - device is ON (S1 = ON) load circuit connected orange: <ul style="list-style-type: none"> - overload or short circuit until electronic disconnection red: <ul style="list-style-type: none"> - device switched OFF electronically load circuit OFF - undervoltage ($U_B < 14\ V$) OFF: <ul style="list-style-type: none"> - manually OFF (S1 = OFF) load circuit physically isolated or device is dead-voltage ● Potential-free signal contact ● On/off position of the switch S1

Load circuit

Load output	power MOSFET switching output (plus switching)
Overload and short circuit disconnection	typically $1.2 \times I_N$ with active current limitation
Trip times for electronic disconnection	see time/current characteristic overload trip time typically 500 ms short circuit trip time depending on current rating (see table 1)
for physical isolation	typically 5 s (3 ... 9 s)
Temperature disconnection	internal temperature monitoring with physical isolation
Undervoltage monitoring of load output	with hysteresis, no reset required: »OFF« at $U_B < 14\ V$ »ON« at $U_B > 17\ V$
Switch-on delay t_{Start}	typically 2 ms after each ON operation, reset and after applying of U_B
Capacitive loads	up to 40,000 μF
Free-wheeling diode	external free-wheeling diode recommended for inductive load
Parallel connection of several load outputs	not allowed

Error message:

Signal output F	potential-free signal contact switches simultaneously with physical isolation, max. DC 30 V / 2 A, min. DC 12 V / 10 mA
-----------------	--

Technical data ($T_{amb} = 25\text{ °C}$, $U_B = DC\ 24\ V$)

Signal output ESS30-S001 make contact	blue push button is in ON position: aux. contact 13/14-12 is closed blue push button is in OFF position: aux. contact 13/14-12 is open
Signal output ESS30-S002 brake contact	blue push button is in ON position aux. contact 13/14-12 is open blue push button is in OFF position: aux. contact 13/14-12 is closed
Signal output ESS30-S003 changeover contact	blue push button is in ON position: aux. contact 13-14 is closed, 13-12 is open blue push button is in OFF position: aux. contact 13-14 is open, 13-12 is closed

Visual status indication

LED green	U_B is applied and switch S1 is ON and no overload, no short circuit
OFF condition LED off	<ul style="list-style-type: none"> ● device switched off (switch S1 is OFF) ● load circuit physically isolated ● no operating voltage U_B
LED orange	overload conditions > 1.2 times rated current until, electronic disconnection
LED red	electronic disconnection upon overload, short circuit or undervoltage

General data

Fail-safe element	back-up fuse for ESS30-S.. <u>not required</u> due to integral redundant fail-safe element (protective element)
Blade terminals	6.3 mm to EN 60934-6.3-0.8
Housing material	moulded
Mounting	pluggable into power distribution systems for side-by-side mounting (module 17plus or 18plus by E-T-A)
Ambient temperature	0...+60 °C (without condensation, cf. EN 60204-1)
Storage temperature	-40...+70 °C
Humidity	96 hours at 95 % RH, 40 °C to IEC 60068-2-78,-Cab climate class 3K3 to EN60721
Vibration	3 g test to IEC 60068-2-6, test Fc
Degree of protection	operating area IP30 EN 60529 installation area IP00 EN 60529
EMC requirements (EMC directive, CE logo)	noise emission: EN 61000-6-3 susceptibility: EN 61000-6-2
Insulation co-ordination (IEC 60934)	0.5 kV / pollution degree 2 reinforced insulation in operating area
Dielectric strength	(see also dimensions)
operating area	test voltage AC 1000 V
installation area	test voltage AC 500 V
load circuit	
auxiliary contact	test voltage AC 500 V
Insulation resistance (OFF condition)	> 100 M Ω (DC 500 V) between LINE (+) and LOAD (+)
Compliance	CE-marking
Dimensions (w x h x d)	12.5 x 78.5 x 60 mm (tolerances to DIN ISO 286 part 1 IT13)
Operating force	
ON	5...8 N
OFF	7...10 N
Mass	approx. 39 g

4

Preferred types

Preferred types are E-T-A products most frequently used by E-T-A customers. We manufacture E-T-A preferred types in particularly high

volumes. Our preferred types are supplied at shorter lead times than non-standard versions.

Preferred types	Preferred ratings (A)											
	0.5	1	2	3.6	3	4	6	8	10	2 (CL2)	3 (CL2)	3.6 (CL2)
ESS30-S003-DC24V	x	x	x		x	x	x	x	x			x

Order numbering code

Type	ESS30	Electronic circuit breaker with current limitation
Mounting	S	plug-in type
Version	0	with physical isolation in the event of a failure
Signal input	0	without signal input
Signal output:	1	signal make contact (min. 12 V/10 mA; max. 30 V/2 A)
	2	signal break contact (min. 12 V/10 mA; max. 30 V/2 A)
	3	signal change over contact (min. 12 V/10 mA; max. 30 V/2 A)
Operating voltage	DC 24 V	voltage rating DC 24 V
Current ratings	0.5 A (Class 2)	
	1 A (Class 2)	
	2 A	
	3 A	
	3.6 A	
	4 A	
	6 A	
	8 A	
	10 A	
	1 A/2 A adjustable	
	3 A/6 A adjustable	
Approvals	CL2	Class2 (only for 2, 3 and 3.6 A versions)
ESS30 - S 0 0 3 - DC 24 V - 3,6 A-CL2 ordering example		
ESS30 - S 0 0 3 - DC 24 V - 10 A ordering example		

Please be informed that we have minimum ordering quantities to be observed.

Class 2
Meets requirement for Class 2 current limitation
(ESS30-S...-0.5 A/1 A/2 A/3 A/3.6 A)

Custom designed versions

Looking for a version you cannot find in our ordering number code? Please get in touch. We will be pleased to find a solution for you.

Application note

- The user has to ensure that the cable cross section of the load circuit in question complies with the current rating of the ESS31-T used.
- In addition special precautions must be taken in the system or machine (e.g. use of a safety PLC) which reliably prevent an automatic re-start of parts of the system (cf. Machinery Directive 2006/42/EG and EN 60204-1, Safety of Machinery). In the event of a failure (short circuit/overload) the load circuit will be disconnected electronically with physical isolation of the contacts by the ESS31-T.

Approvals of ESS30-S

Approval authority	Standard	File-Certificate Nr.	Rated voltage	Current ratings
UL	UL 2367	E306740	24 V DC	0.5 A...10 A
UL	UL 1310 NEC Class 2	E306740	24 V DC	0.5 A, 1 A, 2 A, 3 A, 3.6 A
UL	UL 2367	E306740	24 V DC	0.5 A...10 A
UL	UL 1077 C22.2 No. 235-04	E67320	24 V DC	0.5 A...10 A, 1 A/2 A, 3 A/6 A
VDE	IEC/EN 60934 (VDE 0642)	40039681	24 V DC	0.5 A...10 A

Table 1: Voltage drop, current limitation, trip times, fail-safe element, max. load current

current rating I_N	typical voltage drop U_{ON} at I_N	active current limitation typically	trip time I_{KS} typically ¹⁾	trip time I_{OL} typically ²⁾	fail-safe element	max. load current at 100 % ON duty		
						$T_{Amb} = 40\text{ °C}$	$T_{Amb} = 50\text{ °C}$	$T_{Amb} = 60\text{ °C}$
0.5 A	90 mV	1.2 x rated current	500 ms	500 ms	2 A	0.5 A	0.5 A	0.5 A
1 A	100 mV	1.2 x rated current	500 ms	500 ms	2 A	1 A	1 A	1 A
2 A	110 mV	1.2 x rated current	500 ms	500 ms	4 A	2 A	2 A	2 A
2 A CL2	130 mV	1.2 x rated current	500 ms	500 ms	4 A	2 A	2 A	2 A
3 A	150 mV	1.2 x rated current	500 ms	500 ms	6.3 A	3 A	3 A	3 A
3 A CL2	200 mV	1.2 x rated current	500 ms	500 ms	4 A	3 A	3 A	3 A
3.6 A	155 mV	1.2 x rated current	350 ms	500 ms	6.3 A	3.6 A	3.6 A	3.6 A
3,6 A CL2	220 mV	1.05 x rated current	450 ms	500 ms	4 A	3,6 A	3,6 A	3,6 A
4 A	160 mV	1.2 x rated current	280 ms	500 ms	6.3 A	4 A	4 A	4 A
6 A	170 mV	1.2 x rated current	150 ms	500 ms	10 A	6 A	6 A	6 A
8 A	190 mV	1.2 x rated current	280 ms	500 ms	15 A	8 A	7.5 A	7 A
10 A	210 mV	1.2 x rated current	200 ms	500 ms	15 A	9.5 A	9 A	8.5 A
1 A/2 A	45 mV/90 mV	1.2 x rated current	500 ms	500 ms	4 A	1 A/2 A	1 A/2 A	1 A/2 A
3 A/6 A	80 mV/160 mV	1.2 x rated current	500 ms/150 ms	500 ms	10 A	3 A/6 A	3 A/6 A	3 A/6 A

Note: When mounted side-by-side without convection the devices can only carry max. 80 % of their rated current continuously (100 % ON duty) due to thermal effect.

¹⁾ short circuit
²⁾ overload

4

Tabelle 2: ESS30-S – Gerätevarianten

Version	Signal input			Signal output:						
				signal output F (aux. contact)			status output SF			
ESS30-S.	without	control input ON/OFF +24 V Control IN+	reset input +24 V ↓ RE	without	single signal make contact (normally open NO)	single signal break contact (normally closed NC)	double auxiliary change over contact	without	status-OUT +24V = OK	status-OUT 0V = OK
001	x				x			x		
002	x					x		x		
003	x						x	x		

Typical time/current characteristic ($T_{amb} = 25\text{ °C}$)

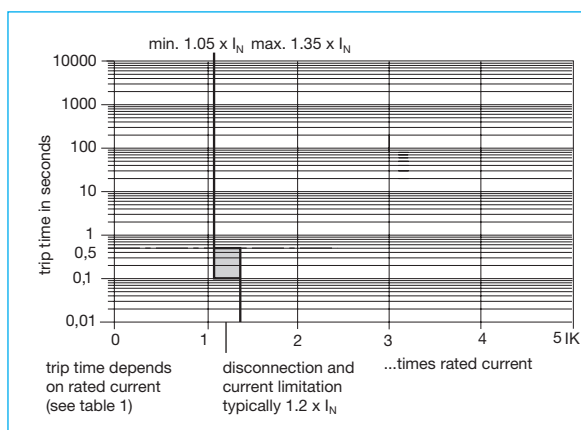

- The overload trip time is typically 500 ms (e.g. ESS30-S...-6A)
- **The electronic current limitation typically begins at $1.2 \times I_N$ (exception: ESS30-S-...-3.6 A CL2 typically $1.05 \times I_N$).** This means: under all overload conditions (independent of power supply and load circuit resistance) typically 1.2 times rated current is applied until disconnection. The corresponding current limitation value I_{Limit} depends on the current rating of the device I_N .
- Without the current limitation getting into effect at typically $1.2 \times I_N$ there would be a much higher overcurrent in the event of an overload or short circuit.
- Reset of the circuit breaker is only possible approximately 10 sec after tripping.

Connection diagram ESS30-S003-... (Example)

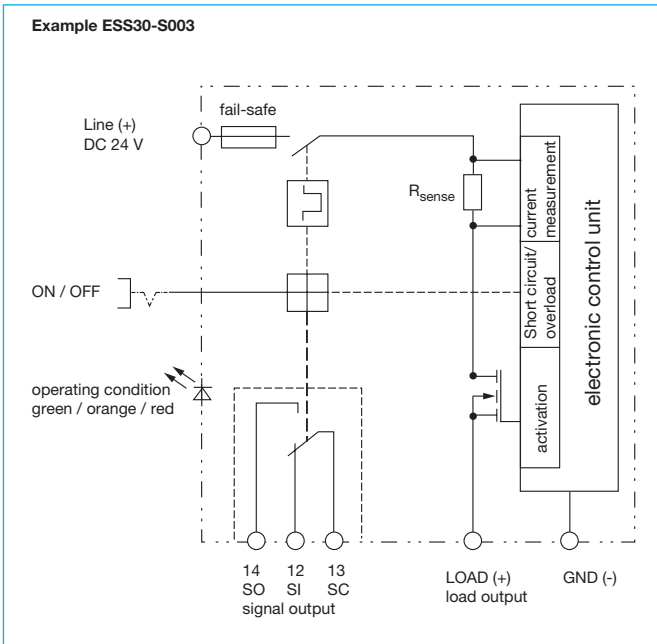

ESS30-S signal output (connection diagrams)

The auxiliary contacts are shown in OFF or fault condition

ESS30-S003
without signal input
with signal output f
single signal, change-over

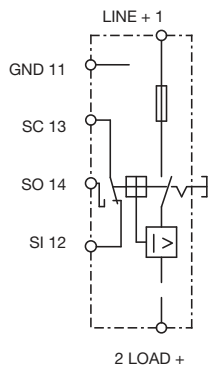

operating condition
13-14 closed; 13-12 open
fault condition
13-14 open; 13-12 closed

Connection diagram ESS30-S003-... (Example)

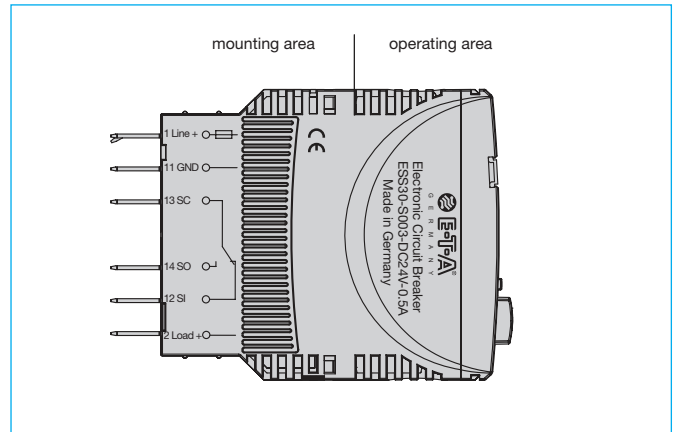

Dimensions ESS30-S

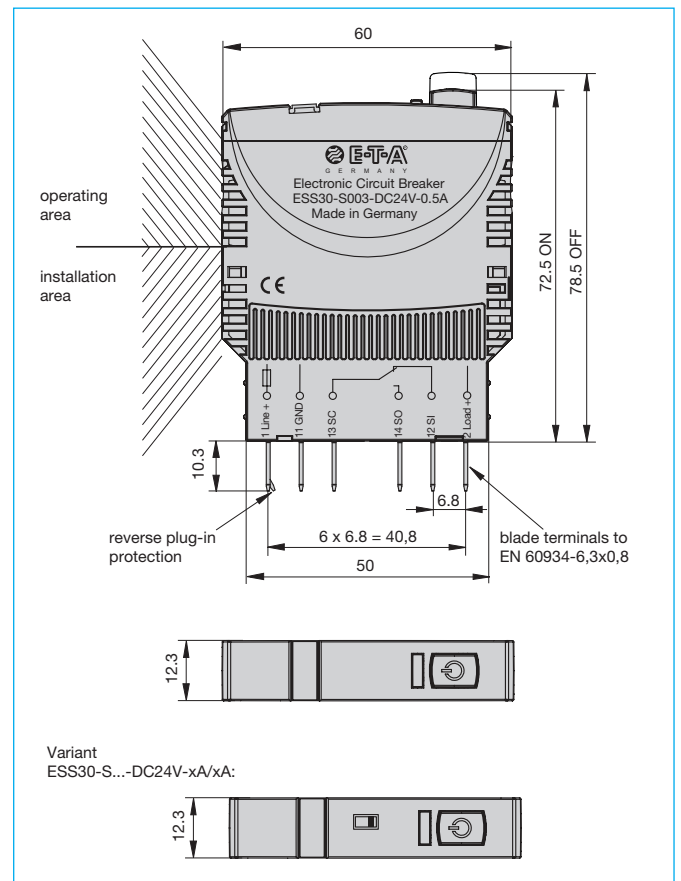

Mounting examples for ESS30-S

Module 17plus

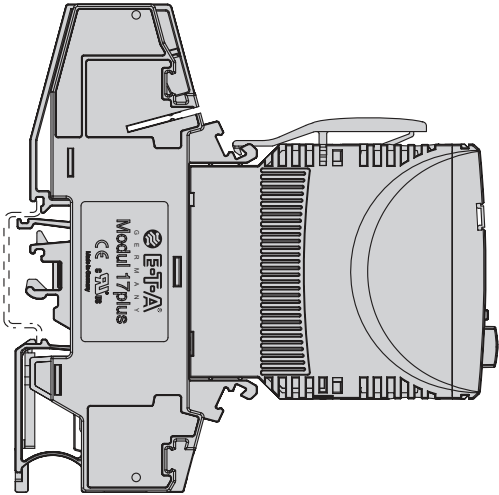

Retaining clip Y 311 978 01

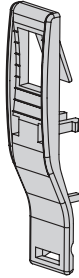

Installation example with ESS30-S with optional retaining clip

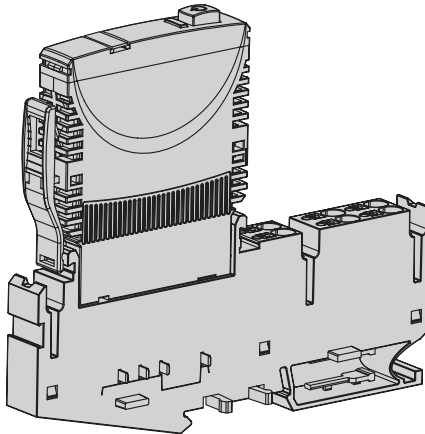

Module 18plus

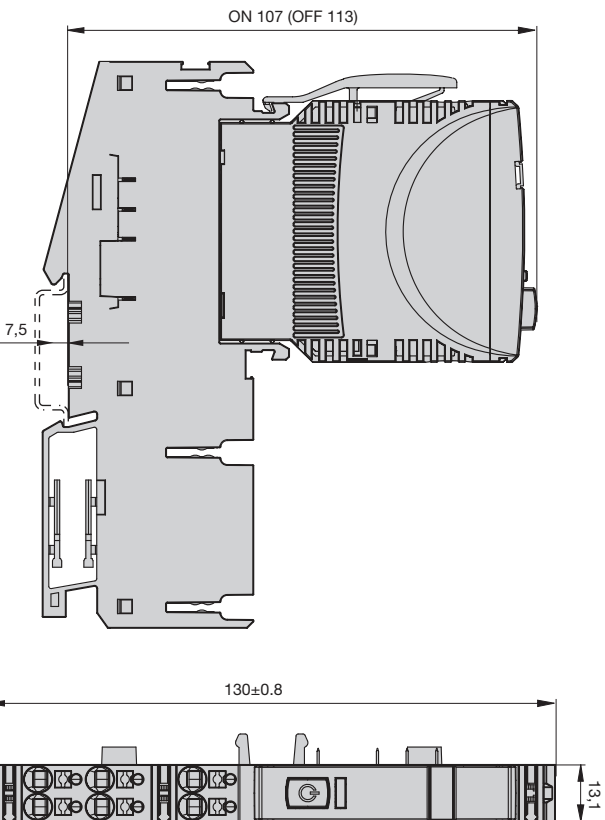

All dimensions without tolerances are for reference only. E-T-A reserves the right change specifications at any time in the interest of improved design, performance and cost effectiveness, the right to make changes in these specifications without notice is reserved. Product markings may not be exactly as the ordering codes. Errors and omissions excepted.