

Datasheet

GNSS

GNSS active antenna

Features:

Frequency 1575-1602 MHz
Polarization RHCP
LNA Gain 28dB
Current consumption 10-15mA
Cable RG-174 with SMA

Applications:

- GPS & Glonass
- Navigation
- Location Based Services
- Fleet management



GNSS Antenna



Electrical Specifications

Antenna Characteristics

Frequency (MHz)	1575.42 ± 3	1602 ± 8
Return Loss (dB)	< -10	< -10
Gain (dBi) @Zenith (28mm × 28mm GND)	-0.5	2.5
Polarization	RHCP	RHCP

LNA Characteristics

Frequency (MHz)	1575.42 ± 3	1602 ± 8
Gain (dB)	28 ± 3	
Noise Figure (dB) @3.0V	1.5 Typ.	
Current Consumption (mA) @3.0V	10~15	
Operation Voltage (V)	2.7~5.0	
Output Impedance (Ω)	50	
ESD (kV)	2.5 HBM	

Total Characteristics

Frequency (MHz)	1575.42 ± 3	1602 ± 8
Gain (dB) at Zenith	27.5 ± 3 – (Cable Loss)	30.5 ± 3 – (Cable Loss)
Output Impedance (Ω)	50	
VSWR	2.0 Max.	

*Note : Cable Loss : 1.4 dB/M (Max.)

Mechanical Specifications

Environmental

Temperature Range (°C)	-40 to 85
Humidity	Non-condensing 65°C 95% RH
IP Rating	IPX7

RoHS Compliant

Part Number	Length (mm)	Weight (g)	Connector Type	Cable Type	Radome
ST0326-41-001-A	50	62.7	SMA	RG-174	ABS

Mechanical Drawing

Unit : mm

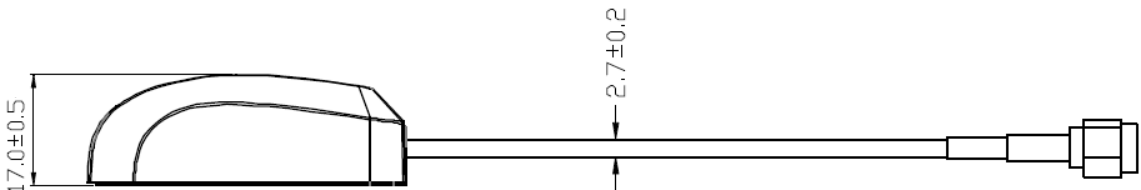
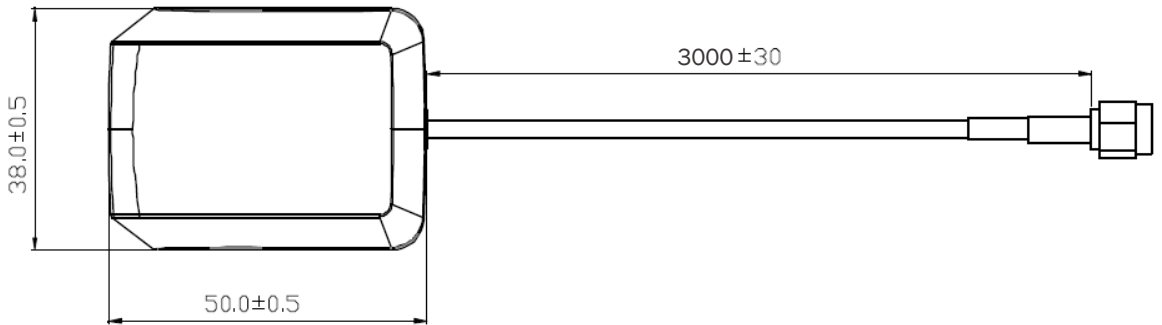

ST0326-41-001-A

Antenna Return Loss

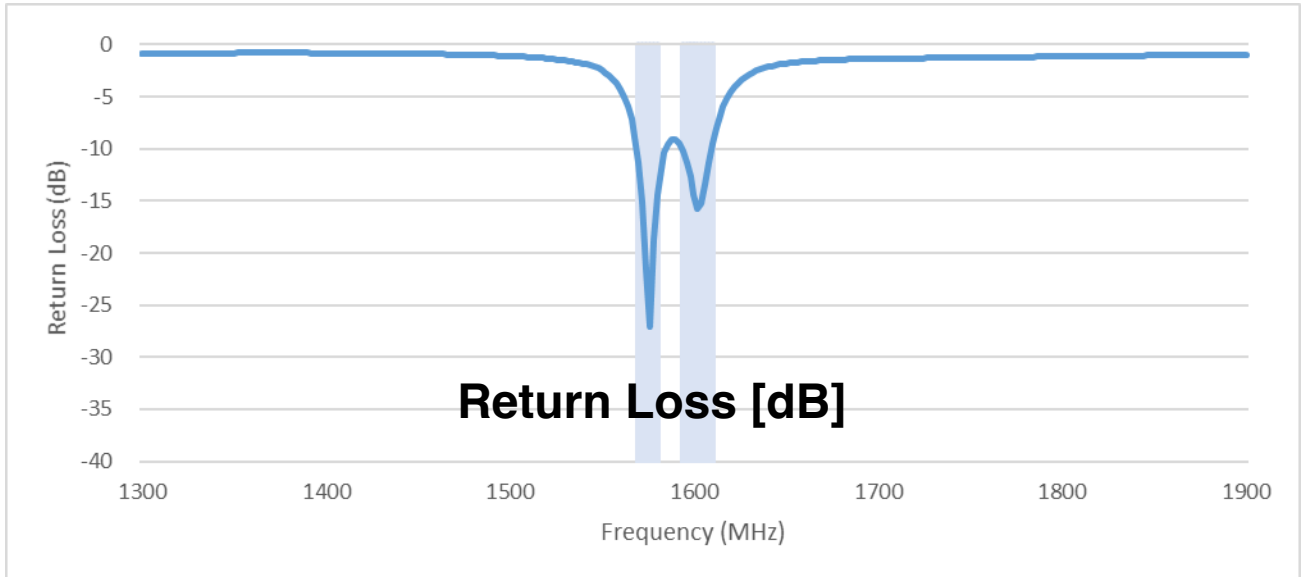

Blue background represents frequency response.

LNA Gain

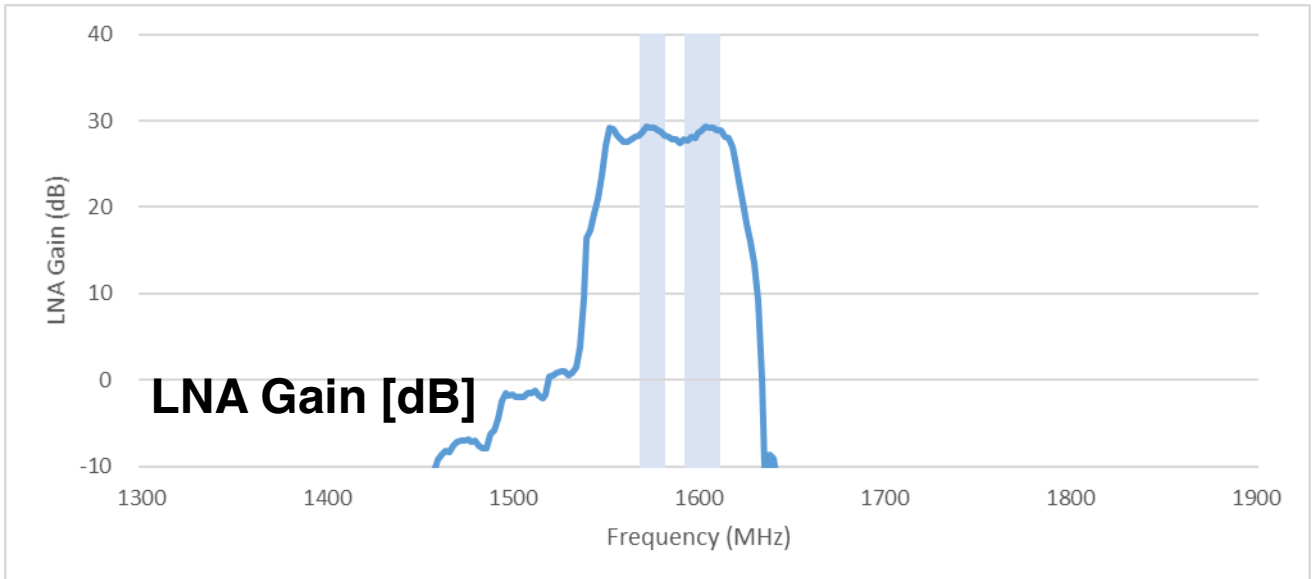

Blue background represents frequency response.

Revisions

Rev	Description	Date	ECN	Approval
A	Initial Release	2022-10-25	ST0326-41-001-A-RA00	ATC

NOTICE - These drawings, specifications, or other data (1) are, and remain the property of Amphenol corp. (2) must be returned upon request; and (3) are confidential and not to be disclosed to any person other than those to whom they are given by Amphenol Corp. the furnishing of these drawings, specifications, or other data by Amphenol Corp., or to any other person to anyone for any purpose is not to be regarded by implication or otherwise in any manner licensing, granting rights to permitting such holder or any other person to manufacture, use or sell any product, process or design, patented or otherwise, that may in any way be related to or disclosed by said drawings, specifications, or other data.