

PLATING THICKNESS
MEASUREMENT LOCATION

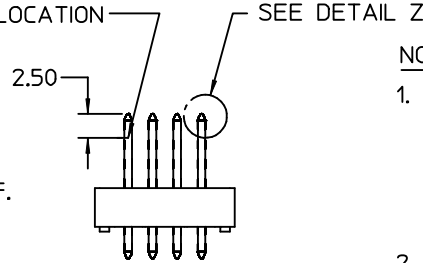

NOTES :

1. MATERIALS :

- WAFER BOARD : 30% GLASS-FILLED LCP,
(LIQUID CRYSTAL POLYMER)
COLOR - BLACK

- PINS : BRASS ALLOY C-26000, 3/4 HARD.
.00050/(0.0013) NICKEL PLATE
MOLEX SPECIFICATION : ES-88-121

3. PRODUCT SPECIFICATION : N/A

4. TAPE AND REEL PACKAGING PER PK-45616-001.

5. PIN RETENTION SPECIFICATION : 1.5 Lbs MIN PER PIN.

6. THIS PART CONFORMS TO CLASS B REQUIREMENTS OF
COSMETIC SPECIFICATION PS-45499-002.

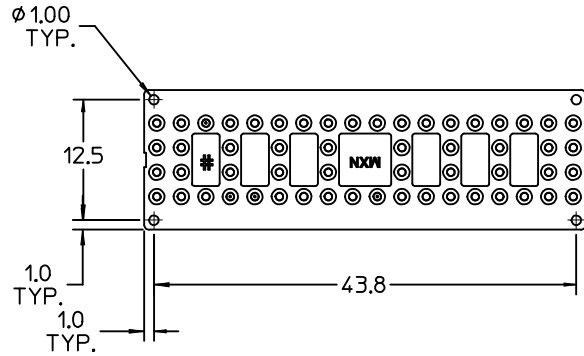
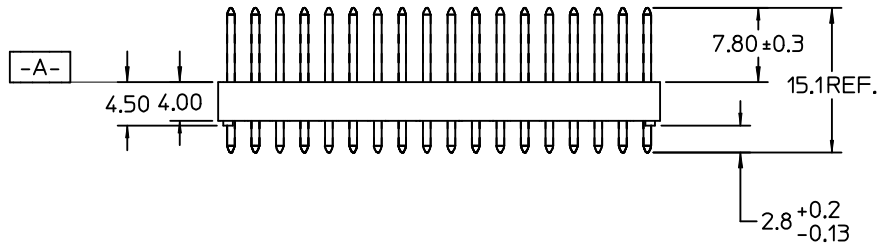

UPDATE NOTES EC NO: UCF2007-3250 DRW:ADRR 2007/06/25 CHKD:JBELL 2007/06/27 APPR:FSMITH 2007/06/28	QUALITY SYMBOLS ▽=0 ▽=0	GENERAL TOLERANCES (UNLESS SPECIFIED)		DIMENSION STYLE MM ONLY	SCALE 2:1	DESIGN UNITS METRIC	THIRD ANGLE PROJECTION		
		4 PLACES ± --- ± ---	DRAWN BY MUELLER	DATE 2003/07/31	TITLE 56 PIN HEADER - ASSEMBLY				
		3 PLACES ± --- ± ---	CHECKED BY MUELLER	DATE 2003/07/31					
		2 PLACES ± 0.13 ± --- 1 PLACE ± 0.25 ± ---	APPROVED BY MARGULIS	DATE 2003/07/31	MOLEX INCORPORATED				
ANGULAR ± 2 °		MATERIAL NO. 456160001	DOCUMENT NO. SD-45616-001	SHEET NO. 1 OF 1					
DRAFT WHERE APPLICABLE MUST REMAIN WITHIN DIMENSIONS		THIS DRAWING CONTAINS INFORMATION THAT IS PROPRIETARY TO MOLEX INCORPORATED AND SHOULD NOT BE USED WITHOUT WRITTEN PERMISSION							

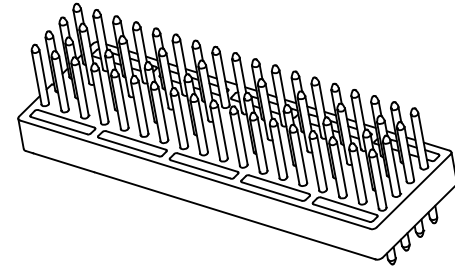
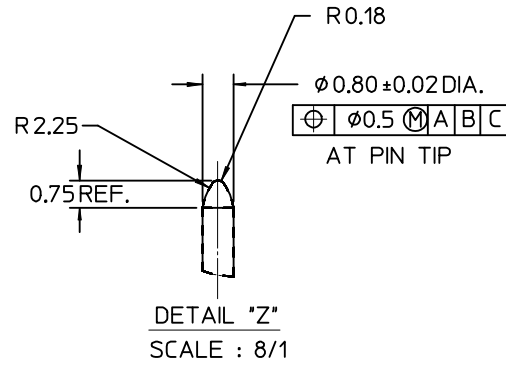
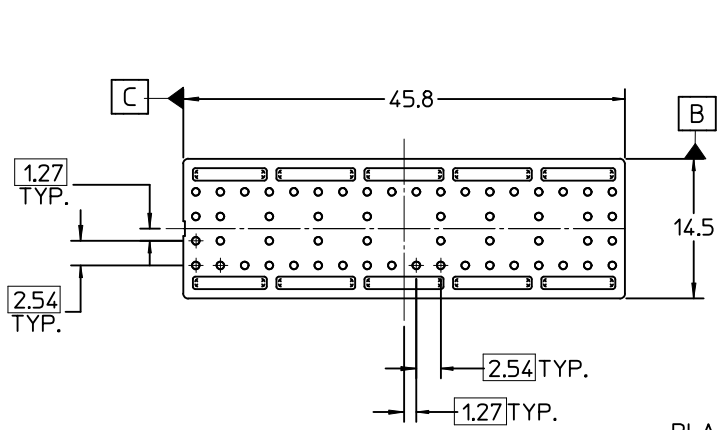

PLATING THICKNESS
MEASUREMENT LOCATION

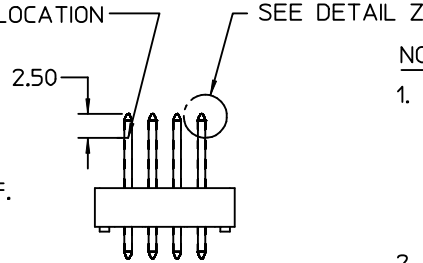

NOTES :

1. MATERIALS :

- WAFER BOARD : 30% GLASS-FILLED LCP,
(LIQUID CRYSTAL POLYMER)
COLOR - BLACK

- PINS : BRASS ALLOY C-26000, 3/4 HARD.
.00050/(0.0013) NICKEL PLATE
MOLEX SPECIFICATION : ES-88-121

3. PRODUCT SPECIFICATION : N/A

4. TAPE AND REEL PACKAGING PER PK-45616-001.

5. PIN RETENTION SPECIFICATION : 1.5 Lbs MIN PER PIN.

6. THIS PART CONFORMS TO CLASS B REQUIREMENTS OF
COSMETIC SPECIFICATION PS-45499-002.

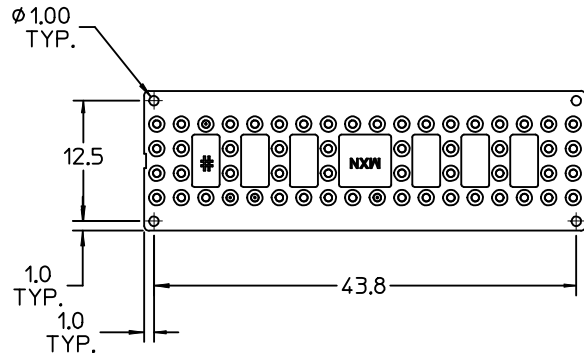
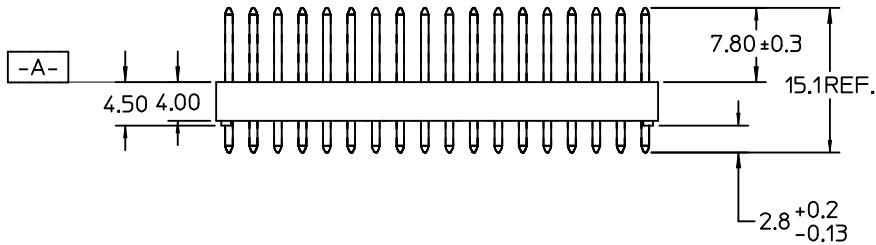

UPDATE NOTES EC NO: UCF2007-3250 DRW:ADDER 2007/06/25 CHKD:JBELL 2007/06/27 APPR:FSMITH 2007/06/28	DESCRIPTION B	QUALITY SYMBOLS ▽=0 ▽=0	GENERAL TOLERANCES (UNLESS SPECIFIED)		DIMENSION STYLE	SCALE	DESIGN UNITS	THIRD ANGLE PROJECTION		
			mm	INCH	MM ONLY	2:1	METRIC			
			4 PLACES ± ---	± ---	DRAWN BY	DATE	TITLE			
			3 PLACES ± ---	± ---	MUELLER	2003/07/31	56 PIN HEADER - ASSEMBLY			
2 PLACES ± 0.13	± ---	CHECKED BY	DATE	MOLEX INCORPORATED MATERIAL NO. 456160001 DOCUMENT NO. SD-45616-001 SHEET NO. 1 OF 1						
1 PLACE ± 0.25	± ---	MUELLER	2003/07/31							
ANGULAR ± 2 °		APPROVED BY	DATE							
DRAFT WHERE APPLICABLE MUST REMAIN WITHIN DIMENSIONS		MARGULIS	2003/07/31							
		SIZE B		THIS DRAWING CONTAINS INFORMATION THAT IS PROPRIETARY TO MOLEX INCORPORATED AND SHOULD NOT BE USED WITHOUT WRITTEN PERMISSION						