

8-BIT INVERTING/NON-INVERTING SCHMITT-TRIGGER BUFFER WITH 3-STATE OUTPUTS

FEATURES

- Operating Range of 2 V to 5.5 V V_{CC}
- 8-Bit Inverting/Non-Inverting Outputs
- 20-Pin Thin Shrink Small-Outline Package [TSSOP (PW)] and 20-Pin Plastic Dual-In-Line Package [PDIP (N)]

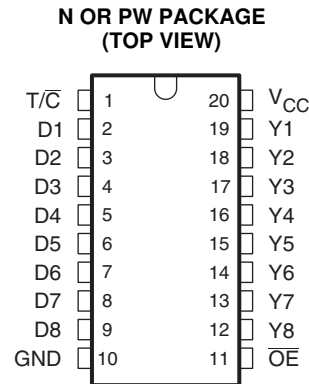

DESCRIPTION

The SN74AHC8541 8-bit inverting/non-inverting buffers are ideal for driving bus lines or buffer memory address registers. These devices feature inputs and outputs on opposite sides of the package to facilitate printed circuit board layout.

All outputs are in the high-impedance state (disabled) when the output-enable (\overline{OE}) input is high. When \overline{OE} is low, the respective gate passes the data from the D input to its Y output.

The T/\overline{C} input selects inverting or non-inverting data transfer. When the T/\overline{C} input is high, it provides non-inverting buffers. When the T/\overline{C} input is low, it provides inverting buffers when they are not in the high-impedance state.

To ensure the high-impedance state during power up or power down, \overline{OE} should be tied to V_{CC} through a pullup resistor; the minimum value of the resistor is determined by the current-sinking capability of the driver.

**FUNCTION TABLE
(EACH BUFFER)⁽¹⁾**

INPUTS			OUTPUT Y
\overline{OE}	T/\overline{C}	D	
L	H	H	H
L	H	L	L
L	L	H	L
L	L	L	H
H	X	X	Z

- (1) L: Low-level
H: High-level
X: Irrelevant
Z: High-impedance (off)



Please be aware that an important notice concerning availability, standard warranty, and use in critical applications of Texas Instruments semiconductor products and disclaimers thereto appears at the end of this data sheet.

LOGIC SYMBOL

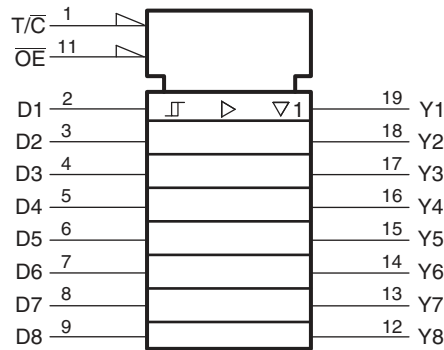

LOGIC DIAGRAM (POSITIVE LOGIC)

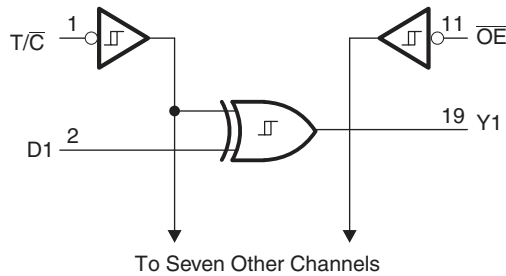

ABSOLUTE MAXIMUM RATINGS⁽¹⁾

		MIN	MAX	UNIT	
V_{CC}	Supply voltage range	-0.5	7	V	
V_I	Input voltage range ⁽²⁾	-0.5	7	V	
V_O	Voltage range applied to any output in the high-impedance or power-off state ⁽²⁾	-0.5	7	V	
	Output voltage range applied in the high- or low-state ⁽²⁾⁽³⁾	-0.5	$V_{CC} + 0.5$	V	
I_{IK}	Input clamp current	$V_I < 0\text{ V}$		-20	V
I_{OK}	Output clamp current	$V_O < 0\text{ V}$ or $V_O > V_{CC}$		±50	mA
I_O	Continuous output current	$V_O = 0\text{ V}$ to V_{CC}		±25	mA
Continuous current through V_{CC} or GND				±50	mA
θ_{JA}	Thermal impedance ⁽⁴⁾	N package		69	°C/W
		PW package		83	
T_{stg}	Storage temperature range	-65	150	°C	

- (1) Stresses beyond those listed under absolute maximum ratings may cause permanent damage to the device. These are stress ratings only, and functional operation of the device at these or any other conditions beyond those indicated under *Recommended Operating Conditions* is not implied. Exposure to absolute-maximum-rated conditions for extended periods may affect device reliability.
- (2) The input and output voltage ratings may be exceeded if the input and output current ratings are observed.
- (3) This value is limited to 5.5 V maximum.
- (4) The package thermal impedance is calculated in accordance with JESD 51-7.

RECOMMENDED OPERATING CONDITIONS⁽¹⁾

over operating free-air temperature range (unless otherwise noted)

		MIN	MAX	UNIT		
V_{CC}	Supply voltage	2	5.5	V		
V_{IH}	High-level input voltage	$V_{CC} = 2\text{ V}$	1.5	V		
		$V_{CC} = 3.3\text{ V} \pm 0.3\text{ V}$	$V_{CC} \times 0.7$			
		$V_{CC} = 5\text{ V} \pm 0.5\text{ V}$	$V_{CC} \times 0.7$			
V_{IL}	Low-level input voltage	$V_{CC} = 2\text{ V}$	0.5	V		
		$V_{CC} = 3.3\text{ V} \pm 0.3\text{ V}$	$V_{CC} \times 0.3$			
		$V_{CC} = 5\text{ V} \pm 0.5\text{ V}$	$V_{CC} \times 0.3$			
V_I	Input voltage	0	5.5	V		
V_O	Output voltage	High or low state		V		
		3-state				
I_{OH}	High-level output current	$V_{CC} = 2\text{ V}$	-50	μA		
		$V_{CC} = 3.3\text{ V} \pm 0.3\text{ V}$	-6	mA		
		$V_{CC} = 5\text{ V} \pm 0.5\text{ V}$	-12			
I_{OL}	Low-level output current	$V_{CC} = 2\text{ V}$	50	μA		
		$V_{CC} = 3.3\text{ V} \pm 0.3\text{ V}$	6	mA		
		$V_{CC} = 5\text{ V} \pm 0.5\text{ V}$	12			
$\Delta t/\Delta V$	Input transition rise or fall rate	$T/\overline{C}, \overline{OE}$	$V_{CC} = 3.3\text{ V} \pm 0.3\text{ V}$	0	100	ns/V
			$V_{CC} = 5\text{ V} \pm 0.5\text{ V}$	0	20	
		D	$V_{CC} = 3.3\text{ V} \pm 0.3\text{ V}$	0	3	ms/V
			$V_{CC} = 5\text{ V} \pm 0.5\text{ V}$	0	2	
t_{pa}	Pulse reception time ⁽²⁾	$V_{CC} = 3.3\text{ V} \pm 0.3\text{ V}$	100	ns		
		$V_{CC} = 5\text{ V} \pm 0.5\text{ V}$	60			
T_A	Operating free-air temperature	-40	85	$^{\circ}\text{C}$		

(1) All unused inputs of the device must be held at V_{CC} or GND to ensure proper device operation.

(2) Buffer inputs D1 to D8 might accept no pulse after t_{pa} period after receiving the first pulse edge. If the input state changes from H to L or L to H in this period, the corresponding output changes from L to H or H to L respectively, in $t_{pa} + t_{pd}$ as delay time in worst-case scenario.

Maximum input frequency, f_{max} , is calculated by the following formula:

$f_{max} = \text{input pulse duty cycle} / (t_{pa(\min)} + t_{pd(\max)})$ when input pulse duty cycle <50%

$f_{max} = (1 - \text{input pulse duty cycle}) / (t_{pa(\min)} + t_{pd(\max)})$ when input pulse duty cycle >50%

ELECTRICAL CHARACTERISTICS

over operating free-air temperature range (unless otherwise noted)

PARAMETER		TEST CONDITIONS	V _{CC}	MIN	TYP ⁽¹⁾	MAX	UNIT
V _{T+}	Positive-going input threshold voltage	D	3.3 V			2.31	V
			5 V			3.5	
V _{T-}	Negative-going input threshold voltage	D	3.3 V	0.99			V
			5 V	1.5			
ΔV _T	Hysteresis (V _{T+} – V _{T-})	D	3.3 V	0.33		1.32	V
			5 V	0.5		2	
V _{OH}	High-level output voltage	I _{OH} = –50 μA	2 V	1.9			V
		I _{OH} = –6 μA	3 V	2.48			
		I _{OH} = –12 μA	4.5 V	3.8			
V _{OL}	Low-level output voltage	I _{OL} = 50 μA	2 V			0.1	V
		I _{OL} = 6 μA	3 V			0.44	
		I _{OL} = 12 μA	4.5 V			0.55	
I _I	Input current	V _I = 5.5 V or GND	0 V to 5.5 V			±1	μA
I _{OZ}	OFF-state output current	V _O = V _{CC} or GND	5.5 V			±5	μA
I _{CC}	Supply current	V _I = V _{CC} or GND, I _O = 0 A	5.5 V			20	μA
C _I	Input capacitance	V _I = V _{CC} or GND	5 V		3		pF
C _O	Output capacitance	V _O = V _{CC} or GND	5 V		5		pF
C _{pd}	Power dissipation capacitance	f = 1 MHz, no load	5 V		15		pF

(1) All typical values are at T_A = 25°C.

SWITCHING CHARACTERISTICS

V_{CC} = 3.3 V ±0.3 V, T_A = –40°C to 85°C, see [Figure 1](#)

PARAMETER	FROM (INPUT)	TO (OUTPUT)	LOAD CAPACITANCE	MIN	TYP	MAX	UNIT
t _{pd}	D	Y	C _L = 15 pF	1	15	29	ns
			C _L = 50 pF	1	18	34	
	T/ \bar{C}		C _L = 15 pF	1	16	30	
			C _L = 50 pF	1	20	36	
t _{en}	\overline{OE}	Y	C _L = 15 pF	1	9	16	ns
			C _L = 50 pF	1	11	20	
t _{dis}	\overline{OE}	Y	C _L = 15 pF	1	8	14	ns
			C _L = 50 pF	1	11	18	

SWITCHING CHARACTERISTICS

V_{CC} = 5 V ±0.5 V, T_A = –40°C to 85°C, see [Figure 1](#)

PARAMETER	FROM (INPUT)	TO (OUTPUT)	LOAD CAPACITANCE	MIN	TYP	MAX	UNIT
t _{pd}	D	Y	C _L = 15 pF	1	10	16	ns
			C _L = 50 pF	1	12	20	
	T/ \bar{C}		C _L = 15 pF	1	11	17	
			C _L = 50 pF	1	13	21	
t _{en}	\overline{OE}	Y	C _L = 15 pF	1	6	10.5	ns
			C _L = 50 pF	1	8	12.5	
t _{dis}	\overline{OE}	Y	C _L = 15 pF	1	6	10	ns
			C _L = 50 pF	1	8	11.5	

NOISE CHARACTERISTICS⁽¹⁾

$V_{CC} = 5\text{ V}$, $C_L = 50\text{ pF}$, $T_A = -40^\circ\text{C}$ to 85°C

PARAMETER		MIN	TYP	MAX	UNIT
$V_{OL(P)}$	Quiet output, maximum dynamic V_{OL}		0.4		V
$V_{OL(V)}$	Quiet output, minimum dynamic V_{OL}		-0.4		V
$V_{OH(V)}$	Quiet output, minimum dynamic V_{OH}		4.5		V
$V_{IH(D)}$	High-level dynamic input voltage	3.5			V
$V_{IL(D)}$	Low-level dynamic input voltage			1.5	V

(1) Characteristics are for surface-mount packages only.

PARAMETER MEASUREMENT INFORMATION

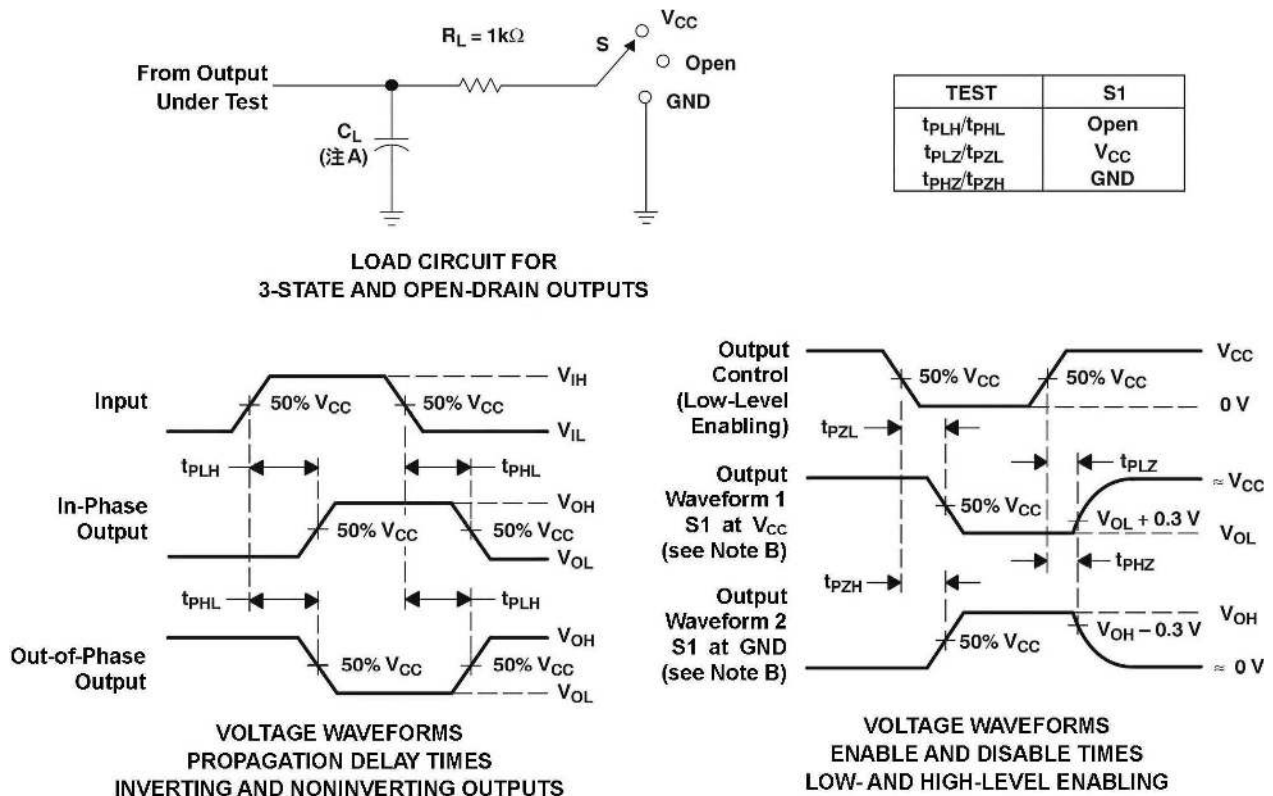

- A. C_L includes probe and jig capacitance.
- B. Waveform 1 is for an output with internal conditions such that the output is low except when disabled by the output control.
Waveform 2 is for an output with internal conditions such that the output is high except when disabled by the output control.
- C. All input pulses are supplied by generators having the following characteristics: $PRR \leq 1\text{ MHz}$, $Z_O = 50\ \Omega$, $t_r \leq 3\text{ ns}$, $t_f \leq 3\text{ ns}$.
- D. The outputs are measured one at a time with one transition per measurement.
- E. t_{PZL} and t_{PZH} are the same as t_{en} .
- F. t_{PLZ} and t_{PHZ} are the same as t_{dis} .
- G. t_{PLH} and t_{PHL} are the same as t_{pd} .

Figure 1. Load Circuit and Voltage Waveforms

PACKAGING INFORMATION

Orderable Device	Status (1)	Package Type	Package Drawing	Pins	Package Qty	Eco Plan (2)	Lead finish/ Ball material (6)	MSL Peak Temp (3)	Op Temp (°C)	Device Marking (4/5)	Samples
SN74AHC8541N	ACTIVE	PDIP	N	20	20	RoHS & Non-Green	NIPDAU	N / A for Pkg Type	-40 to 85	SN74AHC8541N	Samples

(1) The marketing status values are defined as follows:

ACTIVE: Product device recommended for new designs.

LIFEBUY: TI has announced that the device will be discontinued, and a lifetime-buy period is in effect.

NRND: Not recommended for new designs. Device is in production to support existing customers, but TI does not recommend using this part in a new design.

PREVIEW: Device has been announced but is not in production. Samples may or may not be available.

OBsolete: TI has discontinued the production of the device.

(2) **RoHS:** TI defines "RoHS" to mean semiconductor products that are compliant with the current EU RoHS requirements for all 10 RoHS substances, including the requirement that RoHS substance do not exceed 0.1% by weight in homogeneous materials. Where designed to be soldered at high temperatures, "RoHS" products are suitable for use in specified lead-free processes. TI may reference these types of products as "Pb-Free".

RoHS Exempt: TI defines "RoHS Exempt" to mean products that contain lead but are compliant with EU RoHS pursuant to a specific EU RoHS exemption.

Green: TI defines "Green" to mean the content of Chlorine (Cl) and Bromine (Br) based flame retardants meet JS709B low halogen requirements of <=100ppm threshold. Antimony trioxide based flame retardants must also meet the <=1000ppm threshold requirement.

(3) MSL, Peak Temp. - The Moisture Sensitivity Level rating according to the JEDEC industry standard classifications, and peak solder temperature.

(4) There may be additional marking, which relates to the logo, the lot trace code information, or the environmental category on the device.

(5) Multiple Device Markings will be inside parentheses. Only one Device Marking contained in parentheses and separated by a "~" will appear on a device. If a line is indented then it is a continuation of the previous line and the two combined represent the entire Device Marking for that device.

(6) Lead finish/Ball material - Orderable Devices may have multiple material finish options. Finish options are separated by a vertical ruled line. Lead finish/Ball material values may wrap to two lines if the finish value exceeds the maximum column width.

Important Information and Disclaimer:The information provided on this page represents TI's knowledge and belief as of the date that it is provided. TI bases its knowledge and belief on information provided by third parties, and makes no representation or warranty as to the accuracy of such information. Efforts are underway to better integrate information from third parties. TI has taken and continues to take reasonable steps to provide representative and accurate information but may not have conducted destructive testing or chemical analysis on incoming materials and chemicals. TI and TI suppliers consider certain information to be proprietary, and thus CAS numbers and other limited information may not be available for release.

In no event shall TI's liability arising out of such information exceed the total purchase price of the TI part(s) at issue in this document sold by TI to Customer on an annual basis.

TUBE

*All dimensions are nominal

Device	Package Name	Package Type	Pins	SPQ	L (mm)	W (mm)	T (μm)	B (mm)
SN74AHC8541N	N	PDIP	20	20	506	13.97	11230	4.32

N (R-PDIP-T**)

PLASTIC DUAL-IN-LINE PACKAGE

16 PINS SHOWN



4040049/E 12/2002

- NOTES:
- A. All linear dimensions are in inches (millimeters).
 - B. This drawing is subject to change without notice.
 - (C) Falls within JEDEC MS-001, except 18 and 20 pin minimum body length (Dim A).
 - (D) The 20 pin end lead shoulder width is a vendor option, either half or full width.

IMPORTANT NOTICE AND DISCLAIMER

TI PROVIDES TECHNICAL AND RELIABILITY DATA (INCLUDING DATA SHEETS), DESIGN RESOURCES (INCLUDING REFERENCE DESIGNS), APPLICATION OR OTHER DESIGN ADVICE, WEB TOOLS, SAFETY INFORMATION, AND OTHER RESOURCES "AS IS" AND WITH ALL FAULTS, AND DISCLAIMS ALL WARRANTIES, EXPRESS AND IMPLIED, INCLUDING WITHOUT LIMITATION ANY IMPLIED WARRANTIES OF MERCHANTABILITY, FITNESS FOR A PARTICULAR PURPOSE OR NON-INFRINGEMENT OF THIRD PARTY INTELLECTUAL PROPERTY RIGHTS.

These resources are intended for skilled developers designing with TI products. You are solely responsible for (1) selecting the appropriate TI products for your application, (2) designing, validating and testing your application, and (3) ensuring your application meets applicable standards, and any other safety, security, regulatory or other requirements.

These resources are subject to change without notice. TI grants you permission to use these resources only for development of an application that uses the TI products described in the resource. Other reproduction and display of these resources is prohibited. No license is granted to any other TI intellectual property right or to any third party intellectual property right. TI disclaims responsibility for, and you will fully indemnify TI and its representatives against, any claims, damages, costs, losses, and liabilities arising out of your use of these resources.

TI's products are provided subject to [TI's Terms of Sale](#) or other applicable terms available either on ti.com or provided in conjunction with such TI products. TI's provision of these resources does not expand or otherwise alter TI's applicable warranties or warranty disclaimers for TI products.

TI objects to and rejects any additional or different terms you may have proposed.

Mailing Address: Texas Instruments, Post Office Box 655303, Dallas, Texas 75265
Copyright © 2022, Texas Instruments Incorporated