

© - TE Connectivity. All Rights Reserved.

REVISIONS				
P	LTR	DESCRIPTION	DATE	APVD
	F1	REVISED PER ECN-22-156403	06JUN2022	RK CSD

AMP
WIRE RANGE

26 AWG
STRANDED

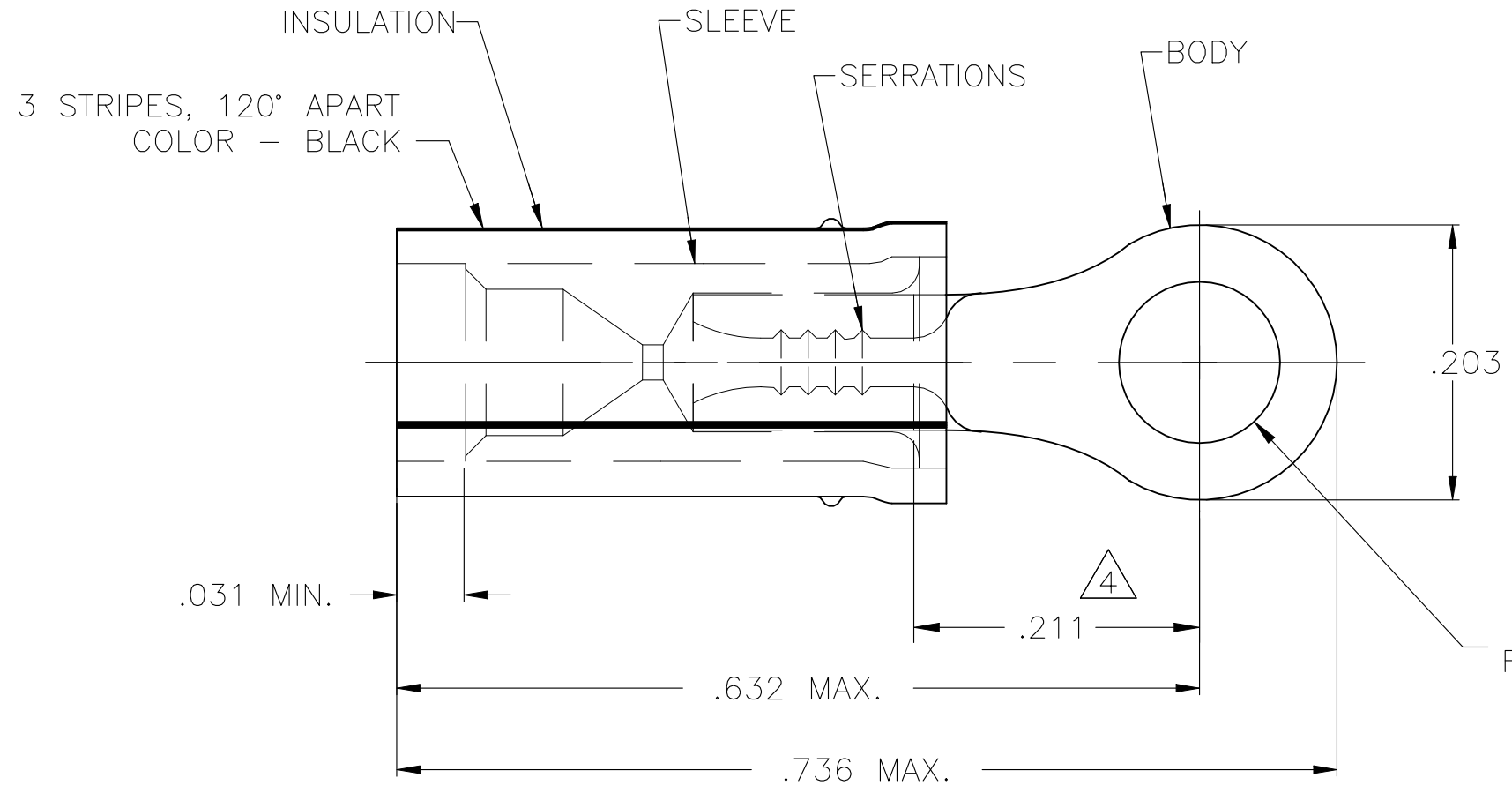

- 1 TONGUE MATERIAL THK: .027±.001.
- 2 FOR .026 TO .055 WIRE INS. OD.
- 3 MUST BE CRIMPED WITH 22-18 OR 22-16 PIDG (RED) TOOL.
- △4 APPLIED FROM EDGE OF METAL WIRE BARREL TO CENTER OF STUD HOLE.
- △5 BODY & SLEEVE: CU PER ASTM B152
INSULATION: NYLON, COLOR - YELLOW.
- △6 BODY: TIN PLATE PER ASTM B545
SLEEVE: NI PLATE PER QQ-N-290.

M7928/1-2 CLASS 1	1	WIRE TERMINAL	53049
MILITARY P/N AND CLASS	QTY	PACKAGE TYPE	PART NO

AMP INCORPORATED CUSTOMER SERVICE SYSTEMS		MAX RECOMMENDED OPERATING TEMPERATURE: 105°C [221°F]	THIS DRAWING IS A CONTROLLED DOCUMENT.		DWN JR RUTH 28OCT08	STE TE Connectivity							
FOR ADDITIONAL PRODUCT INFORMATION OR COPIES OF DRAWINGS AND TECHNICAL DOCUMENTS	PRODUCT INFORMATION CENTER 1-800-522-6752	VOLTAGE RATING: 300V MAX	DIMENSIONS: INCHES	TOLERANCES UNLESS OTHERWISE SPECIFIED:	CHK TOM MICHIELUTTI 28OCT08	TERMINAL, PIDG, RING TONGUE, INSULATION RESTRICTING WIRE SIZE: 26							
FOR APPLICATION TOOLING INFORMATION	TOOLING ASSISTANCE CENTER 1-800-722-1111	CIRCULAR MIL AREA: 0.12-0.15mm² [238-304] STRANDED		0 PLC ± - 1 PLC ± - 2 PLC ± .008 3 PLC ± - 4 PLC ± - ANGLES ± -	APVD TOM MICHIELUTTI 28OCT08								
FOR ORDER ENTRY	1-800-526-5142	THIS DRAWING IS A CONTROLLED DOCUMENT FOR AMP INCORPORATED. IT IS SUBJECT TO CHANGE AND THE CONTROLLING ENGINEERING ORGANIZATION SHOULD BE CONTACTED FOR THE LATEST REVISION.	MATERIAL	FINISH	PRODUCT SPEC -	SIZE A3	CAGE CODE 00779	DRAWING NO C-53049	RESTRICTED TO -	CUSTOMER DRAWING	SCALE 8:1	SHEET 1 OF 1	REV F1