

THIS DRAWING IS UNPUBLISHED. RELEASED FOR PUBLICATION
 © COPYRIGHT - By - ALL RIGHTS RESERVED.

LOC	DIST	REVISIONS			
P	LTR	DESCRIPTION	DATE	DWN	APVD
AF	50	A2	ECR-15-005665	10AUG2015	BDA/ PK

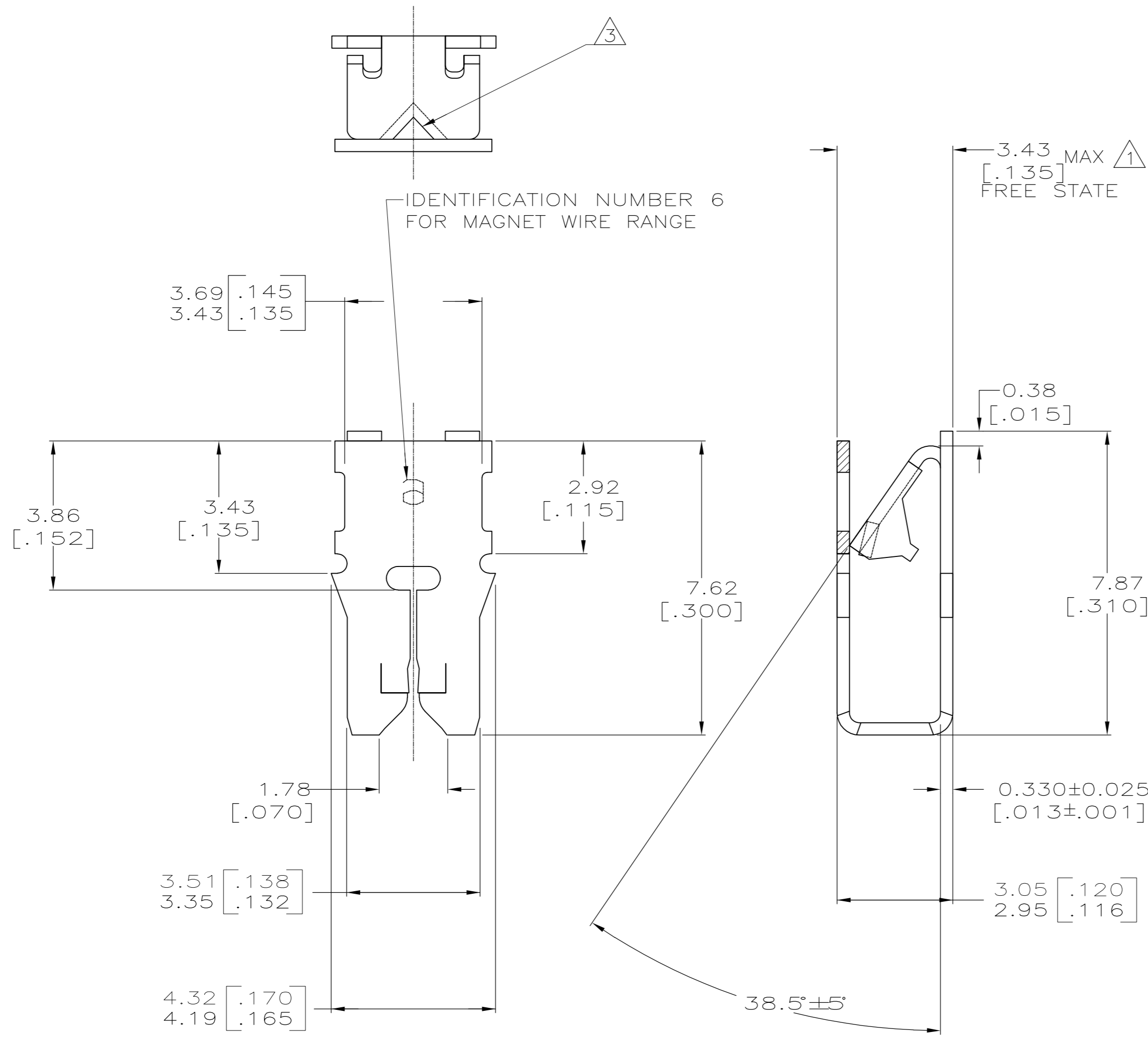

- ① DIMENSION APPLIES WITH LEAF EDGE TOUCHING CARRIER SIDE OF BOX
- ② SLOT TERMINATES EITHER A SINGLE OR DOUBLE MAGNET WIRE OF THE SAME SIZE AND TYPE. COPPER RANGE: 0.25-0.36mm [#30-#27] AWG. ALUMINUM RANGE: 0.32-0.45mm [#28-#25] AWG. ALUMINUM WIRE RANGE APPLIES FOR POST-TIN PLATED VERSIONS ONLY.
- ③ POKE-IN ACCEPTS A 0.5-0.9mm² [#20-#18] AWG SOLID OR FUSED STRANDED LEAD WIRE.
- ④ APPLY BLUE COLORING TO THIS SURFACE DURING LOOSE PIECE OPERATION TO PROVIDE COLOR CODING OF MAGNET WIRE RANGE

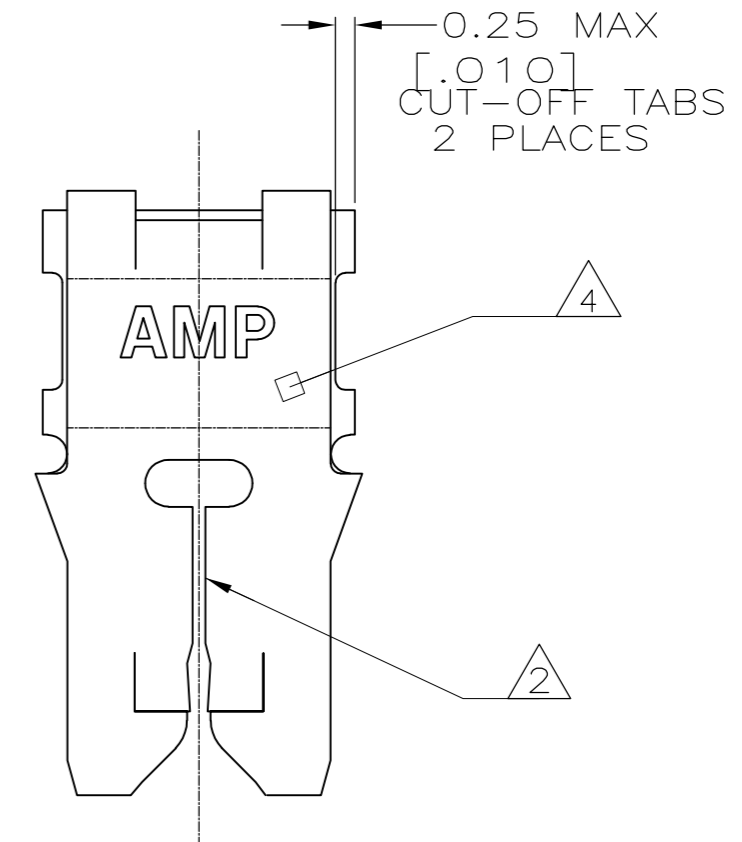

62526-1
PART NUMBER

THIS DRAWING IS A CONTROLLED DOCUMENT.		DWN R.GRZYBOWSKI 21JAN98	TE Connectivity	
DIMENSIONS: INCHES		CHK M.S.FEHER 21JAN98	NAME	
TOLERANCES UNLESS OTHERWISE SPECIFIED:		APVD N.E.NEFF 21JAN98	PRODUCT SPEC	
0 PLC ± -		108-2012		
1 PLC ± -		APPLICATION SPEC		
2 PLC ± 0.25[.010]		114-2046		
3 PLC ± -		WEIGHT -		
4 PLC ± -		SIZE A2 CAGE CODE 00779		
ANGLES ± -		DRAWING NO C=62526		
FINISH		RESTRICTED TO -		
BRASS		SCALE 10:1 SHEET 1 of 1 REV A2		
TIN PLATED		CUSTOMER DRAWING		