

LOC	DIST	P	F	ZONE	LTR	REVISIONS	DATE	APPD
CM	54				R	RLSD -4 AND REV PER EC 0730-0100-94	5-3-94	RV RS

- ① 0.00203 [.000080] MIN BRIGHT TIN-LEAD OVER  
0.00127 [.000050] MIN NICKEL.
- ② 0.00330 [.000130] MAX PRE-TIN.
- ③ 0.00013 [.000005] GOLD OVER 0.00127 [.000050]  
MIN NICKEL ALL OVER AND 0.00076 [.000030] MIN  
GOLD ON CONTACT AREA.
- 4. WIRE RANGE: 0.2-0.9mm<sup>2</sup> (24-18 AWG).  
INSULATION RANGE: 2.79 [.110] DIA MAX.
- 5. DIMENSIONS IN BRACKETS ARE IN INCHES.
- ⑥ 0.00013 [.000005] GOLD OVER 0.00127 [.000050]  
MIN NICKEL ALL OVER AND 0.00038 [.000015] MIN  
GOLD ON CONTACT AREA.

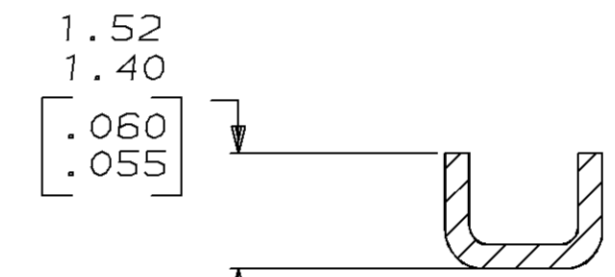

SECTION A-A  
SCALE 10:1

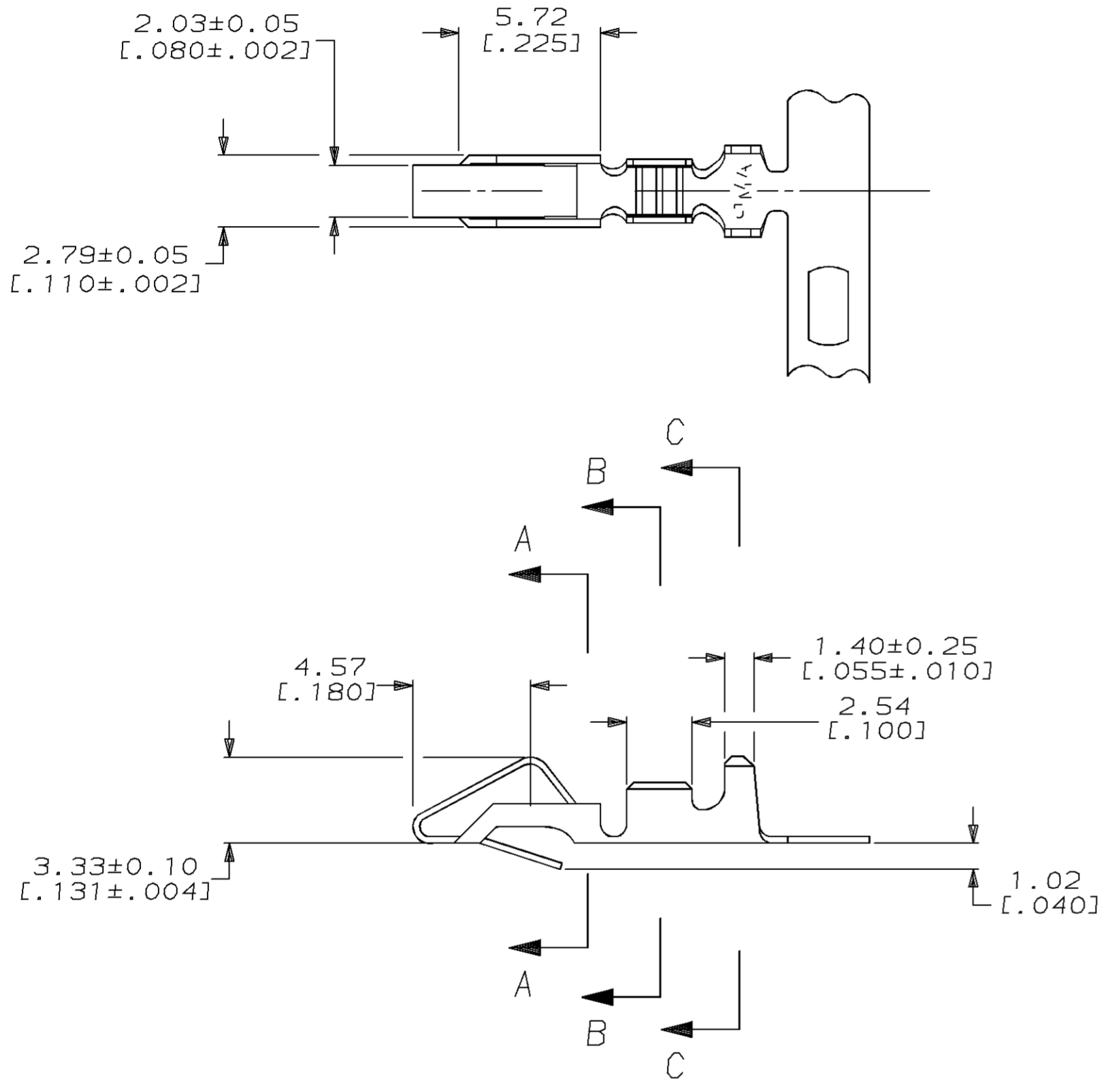
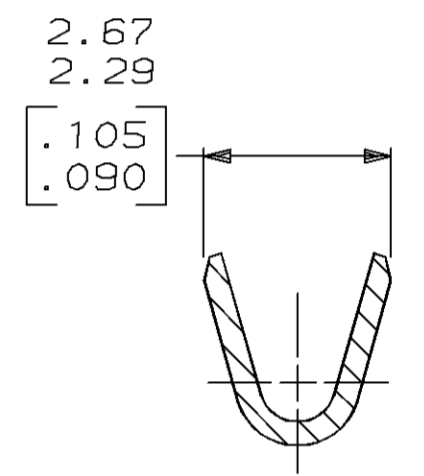

SECTION B-B  
SCALE 10:1

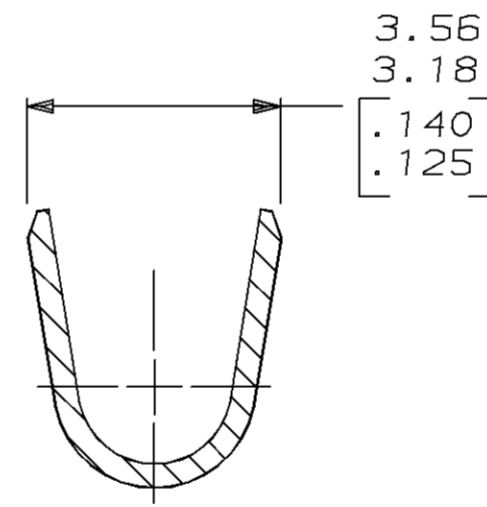

SECTION C-C  
SCALE 10:1

LOOSE PIECE	FINISH	PART NO
—	⑥	350980-4
SEE 770258-1	③	350980-3
—	②	350980-2
SEE 640707-1	①	350980-1

**METRIC**

THIS DRAWING IS A CONTROLLED DOCUMENT FOR AMP INCORPORATED. IT IS SUBJECT TO CHANGE AND THE CONTROLLING ENGINEERING ORGANIZATION SHOULD BE CONTACTED FOR THE LATEST REVISION.

DO NOT SCALE PRINT. UNLESS SPECIFIED DIMENSIONS IN mm [INCHES] TOLERANCES ON : 2 PLC DEC ± 0.13 [.005] 3 PLC DEC ± - ANGLES ± -		DR 11-2-92 K. SALMON		<b>AMP</b> AMP Incorporated Harrisburg, PA 17105-3608	
MATERIAL 0.33 [.013] BRASS		CHK 11-2-92 R. SWING			
FINISH SEE TABLE		APPD 11-20-92 E. BEILES		NAME RECEPTACLE, SL-156	
WEIGHT -		APPD 11-20-92 E. BEILES		SIZE C	
		PRODUCT SPEC -		CAGE CODE 00779	
		APPLICATION SPEC -		DRAWING NO G=350980	
		SCALE 5:1		SHEET 1 OF 1	