



FEATURES:

- AC-DC Constant Current LED Driver
- Input range 90-264VAC/47-440Hz
- High Efficiency up to 82%
- Operating temperature -20 to 80°C
- Total Harmonic Distortion < 20%
- 5 Year Limited Warranty
- Leading or Trailing Edge Triac
- IP20 or IP67 Case
- Active PFC with TRIAC Dimmable^②
- SCP, Over Load Protection

Models Single Output



Model	Max Output Power (W) ^①	Output Voltage Range (V)	No Load Output Voltage (V max.)	Output Current (A)	Input Voltage (VAC/Hz)	Efficiency (%)	
						115 VAC	230 VAC
AMEPR15D-5030AZ+Suffix ^②	15	36-50	62	0.3	90-264/47-440	82	82
AMEPR15D-4835AZ+Suffix ^②	15.8	30-48	62	0.35	90-264/47-440	82	82
AMEPR15D-3650AZ+Suffix ^②	18	24-36	52	0.5	90-264/47-440	81	82
AMEPR15D-2470AZ+Suffix ^②	16.8	12-24	34	0.7	90-264/47-440	81	82
AMEPR15D-15100AZ+Suffix ^②	15	8-15	23	1	90-264/47-440	80	79

^①Exceeding the maximum output power will permanently damage the converter.

^②Model Nomenclature for Ordering:

Add Suffix "-UD"	Universal AC input 90-264VAC, (no TRIAC dimming option), IP20
Add Suffix "-UW"	Universal AC input 90-264VAC, (no TRIAC dimming option), IP67
Add Suffix "-110D"	AC input 90-135VAC, IP20, 115VAC typical value
Add Suffix "-110W"	AC input 90-135VAC, IP67, 115VAC typical value
Add Suffix "-220D"	AC input 180-264VAC, IP20, 230VAC typical value
Add Suffix "-220W"	AC input 180-264VAC, IP67, 230VAC typical value

NOTE: Aimtec limited warranty of 5 years is valid based on product operation at datasheet specifications at ambient temperature of 25°C, humidity<75%, nominal input voltage (115/230VAC) and at rated output load unless otherwise specified. See <http://www.aimtec.com/terms-sale>

AMEPR15D-AZ's AC/DC LED drivers have electrical safeguards designed within to protect it from conventional electrical abnormalities with the levels listed in the safety table. Applications for use within rural agricultural, heavy industrial, and other areas or regions which are prone to 'dirty' electrical conditions which would subject any of the above models to excessive voltages surges or spikes, may damage or cause early life failure of product. In this case consideration should be made by the end user to ensure that adequate line or mains surge suppression is installed in front of Aimtec device to ensure the longevity of the products. Failure to identify excessive line surges violations prior to installation may damage sensitive equipment permanently.

Input Specifications

Parameters	Conditions	Typical	Maximum	Units
Inrush current <2ms (cold start)	115VAC		15	A
	230VAC		25	
Leakage current			25	mA
AC current	115VAC		400	mA
	230VAC		250	
Power Factor	115VAC		0.9	
	230VAC		0.9	
External fuse	Recommend Slow Blown Type	1		A
Start up time		200		ms

Output Specifications

Parameters	Conditions	Typical	Maximum	Units
Current accuracy		±7		%
Line regulation	LL-HL	±10		%
Load regulation	0-100% load	±7		%
Ripple & Noise ^③		3		V p-p
Hold-up time		1		ms
Minimum load voltage	See the models table			

^③ Ripple and Noise are measured at 20MHz bandwidth by using a 0.1µF (M/C) or (C/C) and 47µF (E/C) parallel capacitor.

Isolation Specifications

Parameters	Conditions	Typical	Maximum	Units
Tested I/O voltage	3sec		3000	VAC
Isolation resistance		>1000		MΩ

General Specifications

Parameters	Conditions	Typical	Maximum	Units
Switching frequency		65		KHz
Over load protection		110		%
Over voltage protection		110		%
Short circuit protection		Auto recovery		
Short circuit restart				
Over temperature protection		>105°C		
Operating temperature	With derating over 55°C (for IP67 case)	-20 to +80		°C
Maximum case temperature			100	°C
Storage temperature		-40 to +95		°C
Temperature coefficient		±0.02		% / °C
Cooling		Free air convection		
Humidity			95	% RH
Case material		Plastic		
Wires		UL1015 Input 18AWG*10CM / Output 20 AWG*10CM		
Weight		IP20 160 IP67 200		g
Dimensions (L X H X W)		133 x 33 x 30mm (5.24 x 1.30 x 1.18 inch)		
MTBF		>400,000 hrs (MIL-HDBK-217F at t=+25°C)		

Environment Approval

Test	Parameters	Conditions
Shock	Wave form	Half sine wave
	Acceleration amplitude	5gn
	Bump duration	30 ms
	Converter operation	Before and after test, body mounted (on chassis)
	Number of bumps	18 (3 in each direction for every axis)
Vibration	Test mode	Sweep sine, 10-100Hz, speed 0.05Hz/s
	Displacement	1 mm
	Acceleration	3g, 3 loops 30min one cycle, 3h total, every axis tested
	Converter operation	Before and after test, body mounted (on chassis)

Safety Specifications

Parameters		
Agency approvals	CE, FCC	
Standards	EN61347-1, EN61347-2-13, IEC62384, EN55015, EN55024, FCC Part 15 Subpart B, Class B, ANSI C63.4 :2003 Designed to meet UL8750, IEC/EN 60950-1 standards,	
	Harmonic Current Emissions	IEC/EN 61000-3-2, Class C
	Voltage fluctuations and flicker	IEC/EN 61000-3-3, (EN60555-3)
	Electrostatic Discharge Immunity	IEC 61000-4-2 Level 3
	RF, Electromagnetic Field Immunity	IEC 61000-4-3 Level 2
	Electrical Fast Transient/Burst Immunity	IEC 61000-4-4 Level 2
	Surge Immunity	IEC 61000-4-5 Level 1
	RF, Conducted Disturbance Immunity	IEC 61000-4-6 Level 2
	Power frequency Magnetic Field Immunity	IEC 61000-4-8 Level 2
Voltage dips, Short Interruptions Immunity	IEC 61000-4-11	

Dimensions

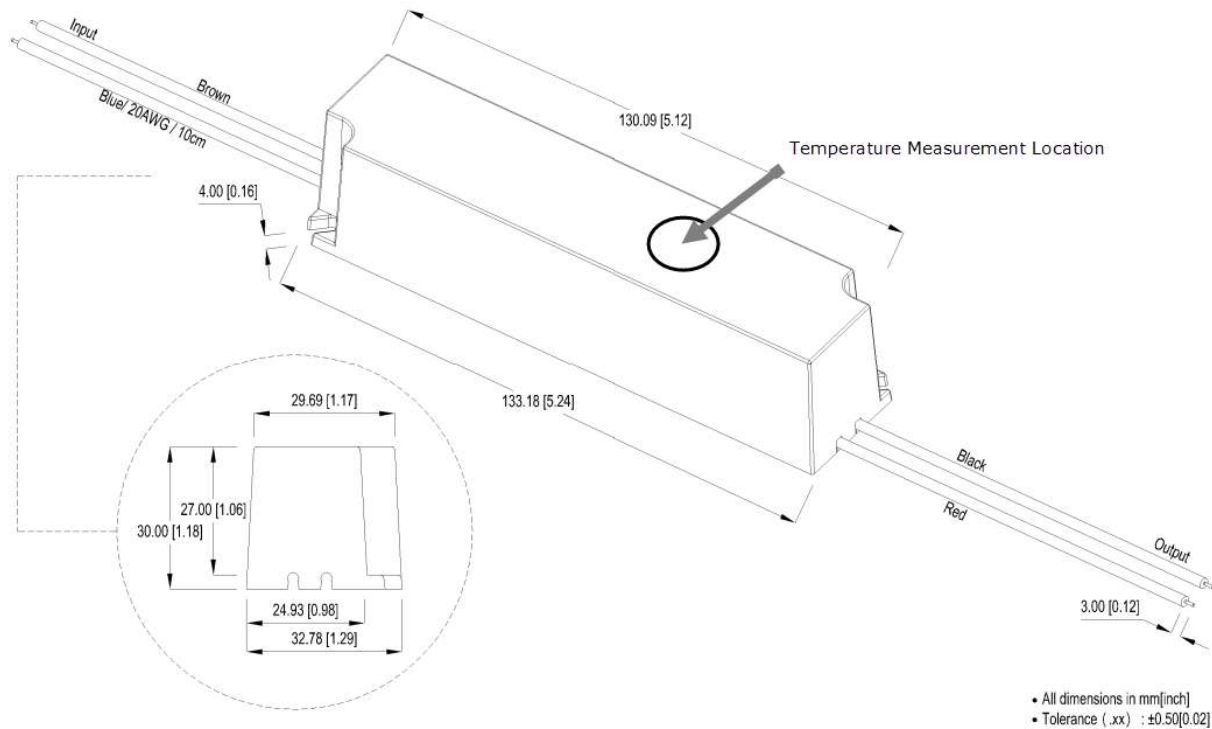

Temperature graph

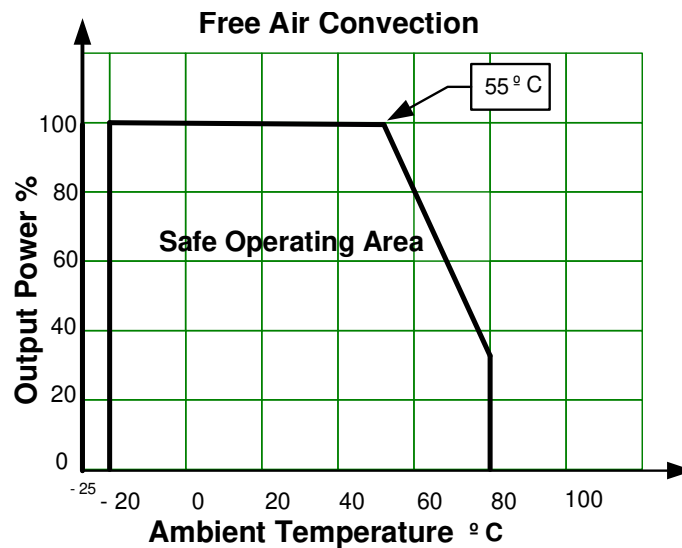

Triac Dimming Feature

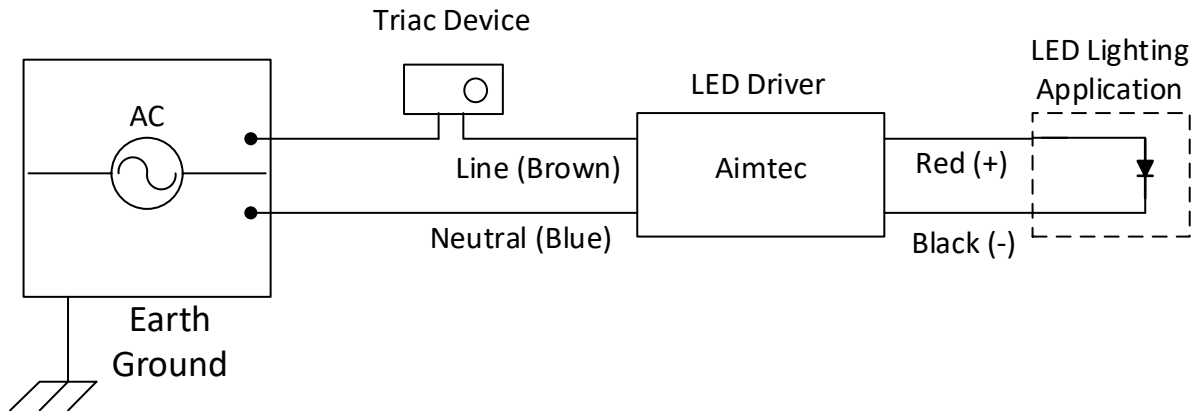

Triac Dimming Notes:

A- The triac device can be installed on either Line or Neutral

B- Aimtec LED drivers have been designed to function with a wide range of available Triac devices, however the following list of Triac devices have been tested.

- 1) Company: LUTRON
Series: SKYLARK
Model: SF-10P-WH (input voltage: 120Vac)
Model: SF-12P-277-WH (input voltage 277Vac)
- 2) Company LUTRON
Series: DIVA
Model: DVF-103P-WH (input voltage: 120Vac)
Model: DVF-103P-277-WH (input voltage: 277Vac)
- 3) Company BERKER
Model: 2867 10 (input voltage:230Vac)

If the power voltage range is 90~135Vac, triac suggested use model SF-10P-WH or DVF-103P-WH.

If the power voltage range is 180~260Vac, triac suggested use model SF-12P-277-WH or DVF-103P-277-WH.

Triac Dimming Performance

AMEPR15D-2470AZ

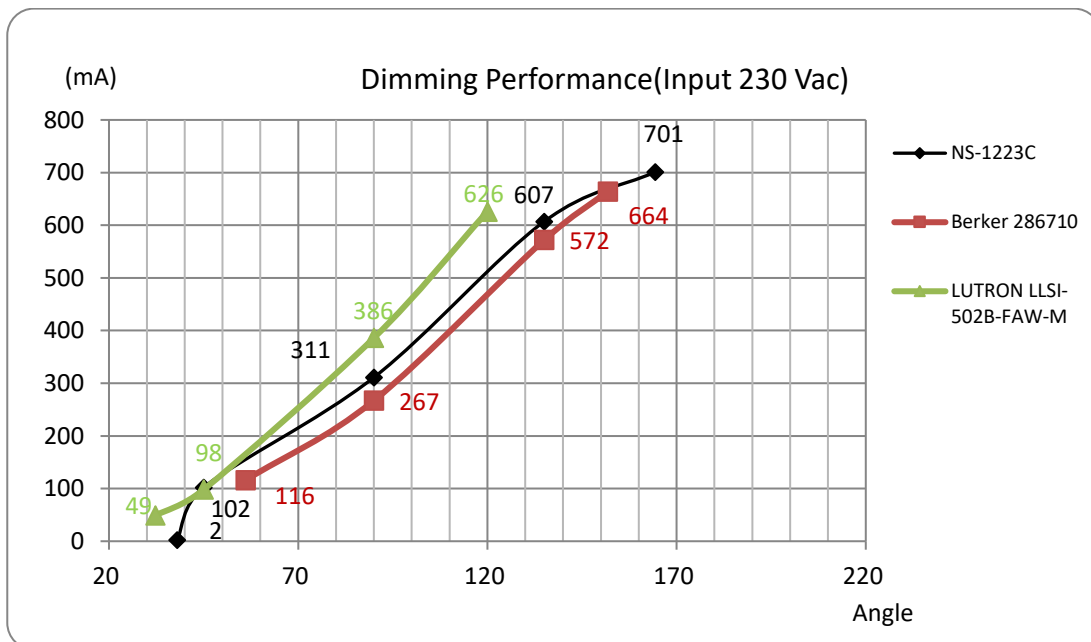
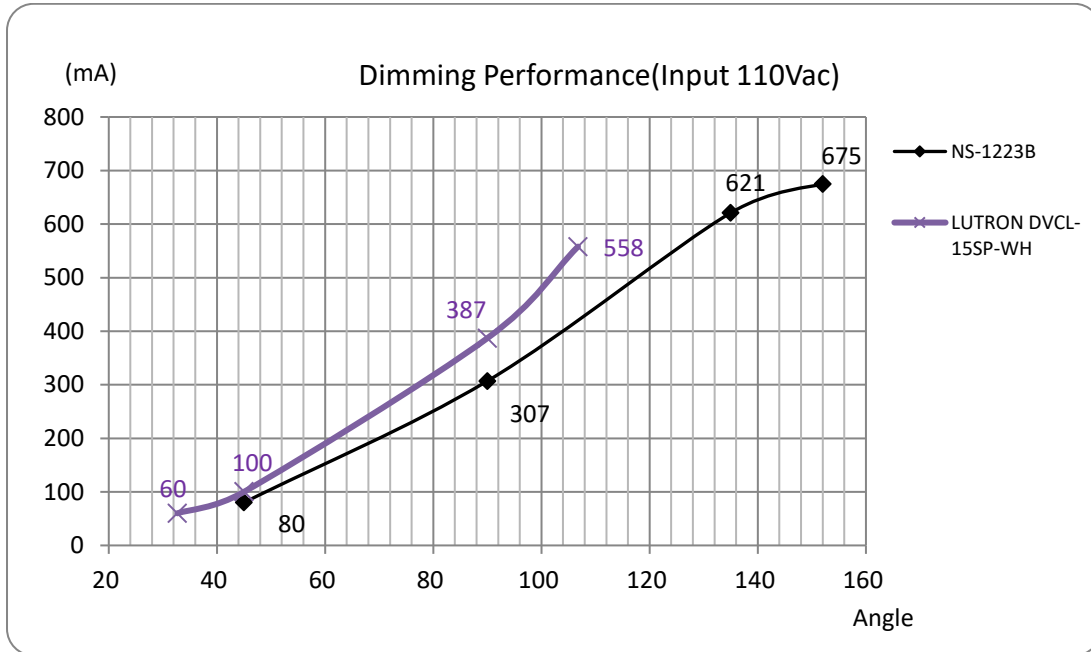

Triac dimming performance is typical as with other models, for specific details on other model performance, please see the Aimtec Triac Dimming Application note at www.aimtec.com

NOTE: 1. Datasheets are updated as needed and as such, specifications are subject to change without notice. Once printed or downloaded, datasheets are no longer controlled by Aimtec; refer to www.aimtec.com for the most current product specifications. 2. Product labels shown, including safety agency certifications on labels, may vary based on the date manufactured. 3. Mechanical drawings and specifications are for reference only. 4. All specifications are measured at an ambient temperature of 25°C, humidity<75%, nominal input voltage and at rated output load unless otherwise specified. 5. Aimtec may not have conducted destructive testing or chemical analysis on all internal components and chemicals at the time of publishing this document. CAS numbers and other limited information are considered proprietary and may not be available for release. 5. This product is not designed for use in critical life support systems, equipment used in hazardous environments, nuclear control systems or other such applications which necessitate specific safety and regulatory standards other the ones listed in this datasheet.