

Transfer or duplication of this document as well as the utilisation or communication of its content are not permitted unless express consent is granted. Violations give rise to claims for damages. All rights reserved in case of patent, utility model or design patent registrations.

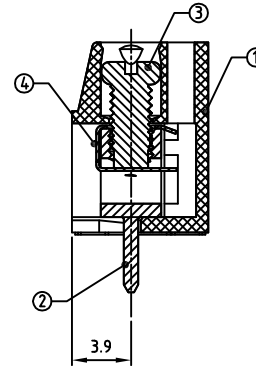
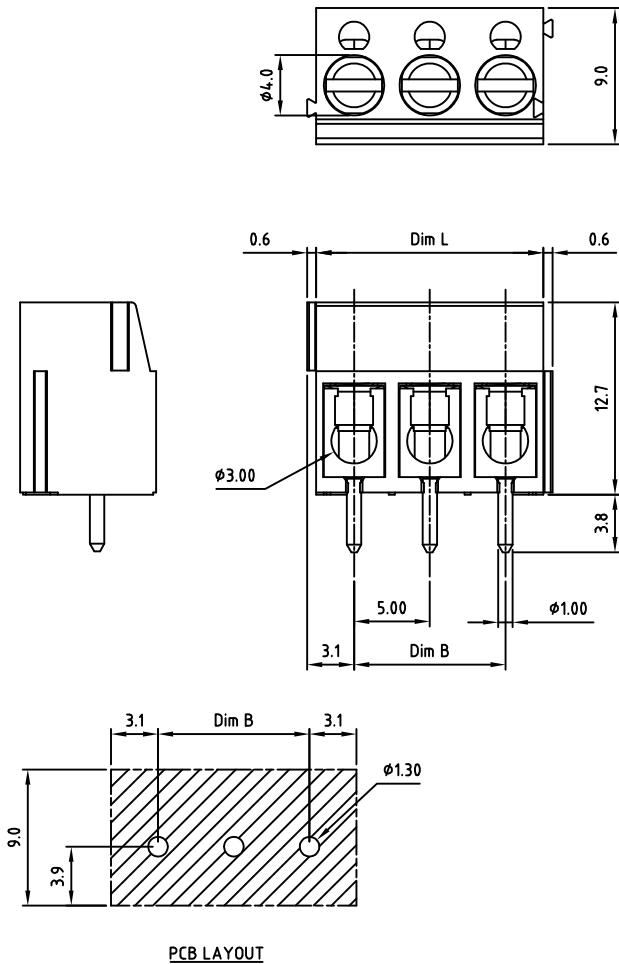

Technical data

- 1.Nominal voltage: 300V/16A
PITCH:5.0mm
- 2.Connection capacity:
AWG 26-14
- 3.Insulation Withstanding Voltage:
AC 1600V/MIN
- 4.Insulation Resistance:
1000MΩ or more at DC500V
- 5.Tightening torque:
4.0kgf.cm (0.4N.m)
- 6.Screw thread: M3
- 7.Stripping length: 6-7mm
- 8.Operating temperature range:-40°C ~ 115°C
Soldering temperature:250±10°C /5s
- 9.Undimensioned Tolerances:

Dim.L=Px5.0		
Dim.B=(P-1)x5.0		
P= number of poles(2-24p)		
0-30mm	Dim B	Dim L
over 30mm-60mm	±0.15	±0.20
over 60mm-90mm	±0.20	±0.25
over 90mm	±0.25	±0.30
	±0.30	±0.40

- 10.Safety approval:
- 11.RoHS Compliance

Part No.:

OSTTAXX0161

No. of Poles	COLOR
02 2 Poles	0: Black
03 3 Poles	2: Red
...	3: Orange
24 24 Poles	4: Yellow
	5: Green
	6: Blue (Standard)
	8: Grey

Nonstandard colors
Mins could apply

4	WIRE GUARD	Stainless steel		P
3	SCREW	STEEL	M3x0.5, Zn Plated	P
2	CAGE	BRASS	M3x0.5, Tin PLATED	P
1	BODY	PA66 UL94V-0	ALL COLOR	1
ITEM	NAME OF PART	MATERIAL	NOTES	Q'TY
DWG.	WF. Zhang	DATE	2015.12.01	UNITS: MM SHEET: 1 OF 1 Tolerance
CHK.	WF. Zhang	DATE	2016.06.12	SCALE: NONE 3:1 (:) REV.: B
APP.		DATE		TITLE: OSTTA 5.0 Series "-" slot 2-Interlock type
				PART NO. OSTTAXX0161
				DWG NO. OSTTAXX0161.dwg

	SIGN	DESCRIPTION	CHK.	DATE
--	------	-------------	------	------

	ON-SHORE TECHNOLOGY, INC.
--	---------------------------