

NOTES:

- MATERIALS AND FINISHES:  
 BAYONET SLEEVE - BRASS, NICKEL PLATING (.000100/.000250) THICK  
 BODIES - BRASS, NICKEL PLATING (.000100/.000250) THICK  
 WASHER - BRASS, NICKEL PLATING (.000100/.000250) THICK  
 CLAMP - BRASS, NICKEL PLATING (.000100/.000250) THICK  
 CONTACT - BeCu, GOLD PLATING (.00005/.0001 THICK) OVER NICKEL  
 OUTER CONTACT - BeCu, GOLD PLATING (.00005/.0001 THICK) OVER NICKEL  
 REAR OUTER CONTACT - BRASS, NICKEL PLATING (.000100/.000250) THICK  
 REAR GASKET - FLUOROSILICONE, COLOR: BLUE  
 FRONT GASKET - SILICONE RUBBER  
 INSULATORS - PTFE  
 SPACER - BRASS, NICKEL PLATING (.000100/.000250) THICK  
 RETAINING RING - BRASS, NICKEL PLATING (.000100/.000250) THICK  
 SPRING WASHER - BeCu, GOLD PLATING (.00005/.0001 THICK) OVER NICKEL  
 FERRULE - COPPER TUBING, NICKEL PLATING (.000100/.000250) THICK
- ELECTRICAL:  
 A. IMPEDANCE: NON-CONSTANT CAN BE USED WITH 50, 75 AND 93 OHM TRIAXIAL CABLES  
 B. FREQUENCY RANGE: DC - 500 MHz
- ENVIRONMENTAL:  
 A. THERMAL: -65°C TO + 165°
- FOR ASSEMBLY INSTRUCTIONS SEE 9-9950-433.
- FERRULE TO BE CRIMPED WITH A .178 HEX DIE.  
 CONTACT TO BE SOLDERED.
- ASTERISK (\*) INDICATES CABLE ENTRY DIMENSIONS.

31-33485-23		REVISIONS			
DRAWING NO.	REV	DESCRIPTION	DATE	ECO	APPR
THIRD ANGLE PROJ.	A	RELEASE TO MFG	3/22/10	48023	GSA
	B	ADDED PARENTHESIS TO STAMP	9/9/11	48728	MJS
	C	SEE SHEET 1	3/13/12	48944	CPM

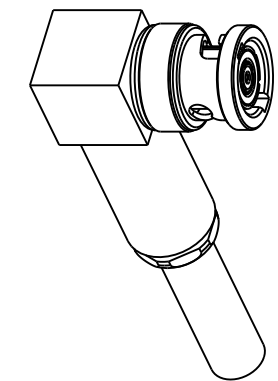
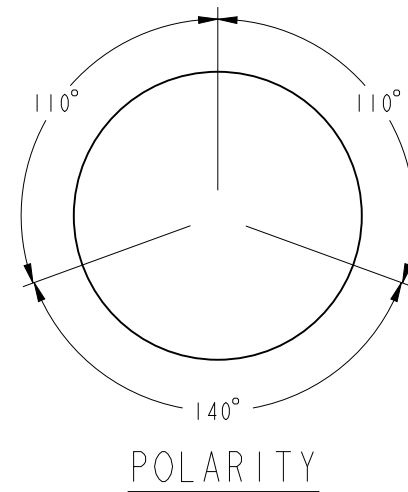

SCALE 1.000

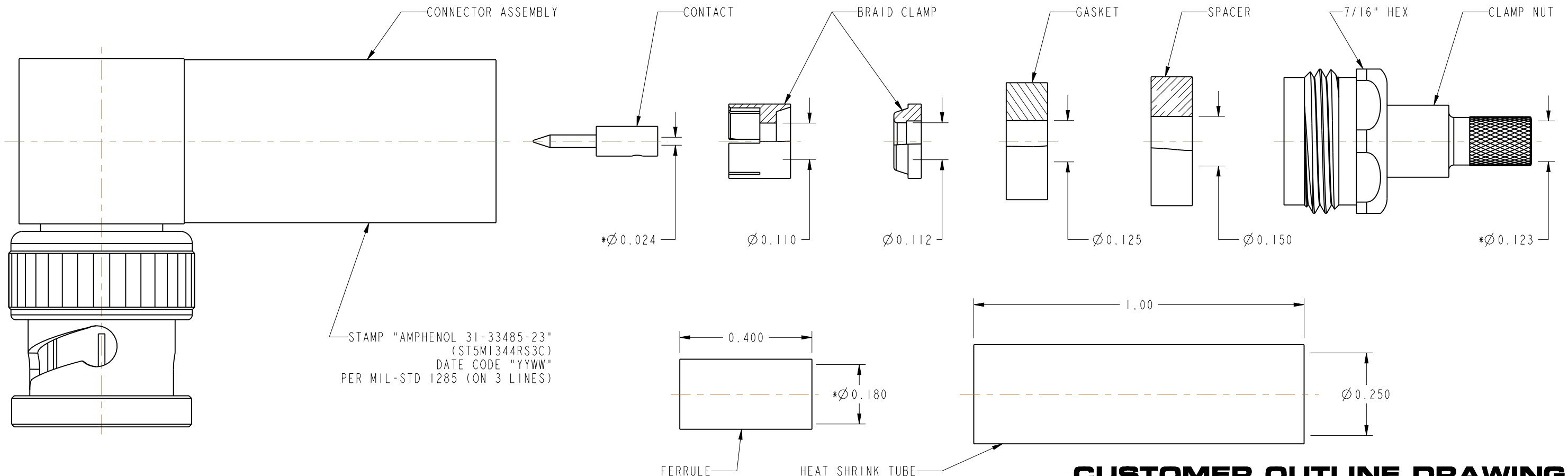

**CUSTOMER OUTLINE DRAWING**  
 ALL OTHER SHEETS ARE FOR INTERNAL USE ONLY

UNLESS OTHERWISE SPECIFIED, DIMENSIONS ARE IN INCHES AND TOLERANCES ARE: 2 PLACE DECIMAL ±.015 (0,381 mm) 3 PLACE DECIMAL ±.005 (0,127 mm) ANGLES ± 1°	MATERIAL	DRAWN BALAJI M	DATE 04-Mar-10	TITLE BNC R/A TRIAX PLUG FOR BOEING 5M2559 AND 5M2397 CABLE	Amphenol RF Danbury, CT, USA Tainan, Taiwan Shenzhen, China www.amphenolrf.com		
	REFERENCE McDONNELL-DOUGLAS SPEC. ST5M1344RS3C	ENGINEER BALAJI M	DATE 04-Mar-10				
NOTICE - These drawings, specifications, or other data (1) are, and remain the property of Amphenol Corp. (2) must be returned upon request; and (3) are confidential and not to be disclosed to any person other than those to whom they are given by Amphenol Corp. The furnishing of these drawings, specifications, or other data by Amphenol Corp., or to any other person to anyone for any purpose is not to be regarded by implication or otherwise in any manner licensing, granting rights or permitting such holder or any other person to manufacture, use or sell any product, process or design, patented or otherwise, that may in any way be related to or disclosed by said drawings, specifications, or other data.	APPROVED K. CAPOZZI	DATE 3/19/10	CODE ID 74868	DWG SIZE B	DRAWING NO. 31-33485-23	SCALE: 3.3:1	SHEET 2 OF 2
	CAD FILE I:\TRIA\31-33485-23						