



Entry+ Module XM124
Entry+ Module XM123
Datasheet v1.3



Abstract

The Entry+ Module XM124 is an integration ready Land Grid Array (LGA) module for compact commercial products that measures 18.6x15 mm. Optimized for use cases such as smart people presence, motion detection, parking space occupancy detection, and level measurement for example in tanks or waste containers.

The XM123 is an integration ready Land Grid Array (LGA) module for compact commercial products that measures 18.6x15mm. Dedicated for smart people presence and motion detection only. Note that the Entry+ Module XM123 to be used with XM123 software (SDK), Sparse service only.

The XM124 and the Entry+ Module XM123 is built around the Arm® 32-bit Cortex®-M4 MCU from STMicroelectronics (STM32L431CBY6) and can be used as a stand-alone module where customer can embed their application on top of the Acconeer RSS (Radar System Software). It can also be used with an external host controller where communication to the module is executed via a register command protocol.

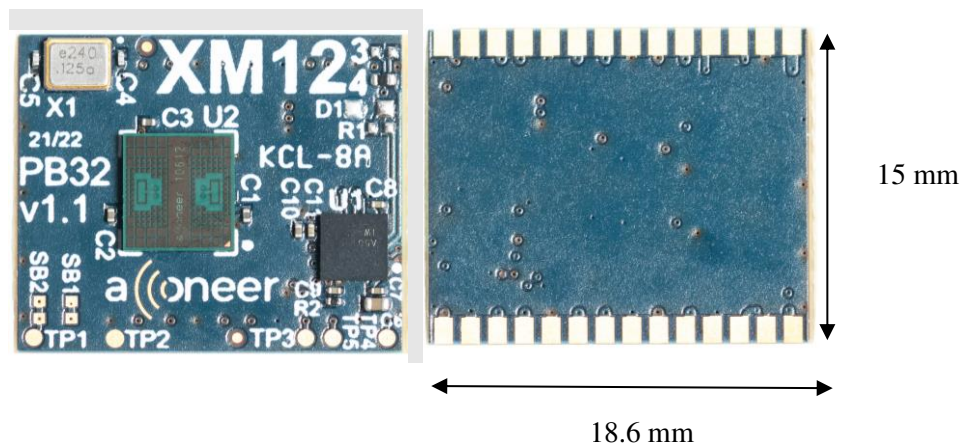

Figure 1.1. XM124/XM123 top view (left) and bottom view (right).



Table of Content

1	Revision History	4
2	Functional description.....	5
2.1	Overview	5
2.2	Product features.....	5
2.3	Block diagram	6
2.4	Module board Land Grid Array description.....	6
2.5	Software options.....	9
3	Interfaces	10
3.1	Module supply input.....	10
3.2	System functions	10
3.3	Serial interfaces	10
3.4	I/O interfaces	10
3.5	Module reset.....	10
4	Electrical specifications	11
4.1	Absolute maximum ratings	11
4.2	Recommended operating conditions	11
4.3	Power consumption summary	12
4.4	RF specification.....	12
4.5	Typical characteristics, Radar Loop Gain pattern	13
5	Reference design description	14
5.1	Schematics & BOM.....	14
6	Mechanical specifications and footprint	17
6.1	Moisture Sensitivity Level and Recommended Reflow Profile	18
6.2	RoHS and REACH Statement.....	18
7	Regulatory Approval.....	19
7.1	ETSI	19
7.2	FCC Approval	19
8	Reference documents	20
9	Abbreviations	21
	Disclaimer	22



1 Revision History

Revision	Comment
v1.0	Released version
v1.1	Updated schematic to A4 colored version. Added measured RLG patterns.
v1.2	Chapter 7 updated
v1.3	Added recommended footprint to chapter 6. Added information on VIN voltage ripple specification to chapter 3.1. Added current profile to chapter 4.3.

This document applies to the following product:

Product name	Part number
XM124	XM124
XM123	XM123



2 Functional description

2.1 Overview

The Entry+ Modules XM123 and XM124 comes with the A111 60 GHz PCR sensor and a 32-bit ARM® Cortex® M4 MCU, see Figure 2.1. The two variants have the same PCB but different component mounting options. The resistors R3 and R4 identify the two different variants.

The XM124 module is optimized for high precision people presence detection with capability to recognize movement within configurable zones, motion detection, parking space occupancy detection and level measurement for example in tanks or waste containers with configurable update frequency.

The XM123 module is a cost sensitive limited variant supporting the Acconeer Sparse Service which is suitable for applications such as people presence and motion detection.

The modules have been optimized for easy integration with LGA solder pads support, a small form factor of 18.6x15 mm and single supply operating voltage 1.8 V.

The modules are delivered with a bootloader which enables the customer to download the Acconeer Radar System Software (RSS) software as well as the SDK (Software Development Kit) for stand-alone usage where the customer can embed their own application on top of RSS software. The RSS software provides the API to set A111 sensor configuration and to retrieve supported radar services and detector data. The RSS enables interfacing through an external host using a register command protocol over UART and I2C.

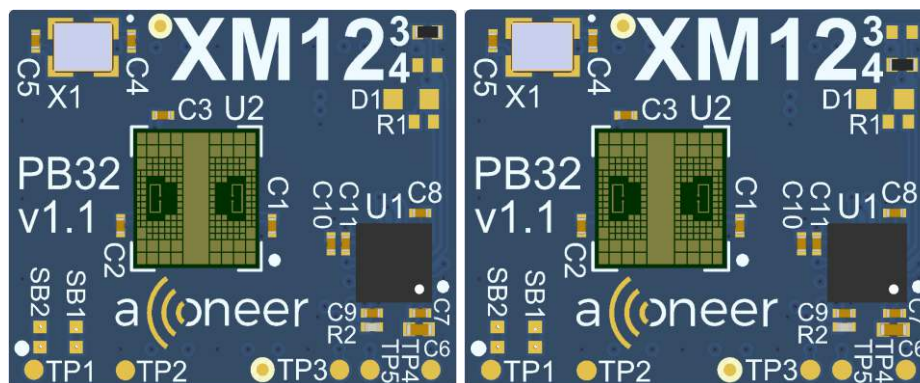

Figure 2.1. The XM123 (left) and XM124 (right) modules.

2.2 Product features

The modules have the following features:

- A111 60 GHz Pulsed Coherent Radar (PCR) with integrated baseband, RF front-end and Antenna in Package (AiP)
- 32-bit ARM® Cortex® M4 MCU (STM32L431CBY6), 80 MHz clk speed, 128kB Flash, 64 kB RAM
- Small 18.6x15 mm form factor, optimized for maximum antenna gain
- Single supply operating voltage 1.8 V
- Operating temperature -40° to 85°C
- External I/F support over UART, I2C, GPIO, reset
- SWD/JTAG for SW flash and debug
- Can be integrated behind plastic or glass radomes without any need for a physical aperture. See *Hardware and physical integration guideline* [6] for more information.
- Land Grid Array (LGA) solder pads



- Available in hermetically sealed reels for automated assembly
- PCB test points for SWD programming

2.3 Block diagram

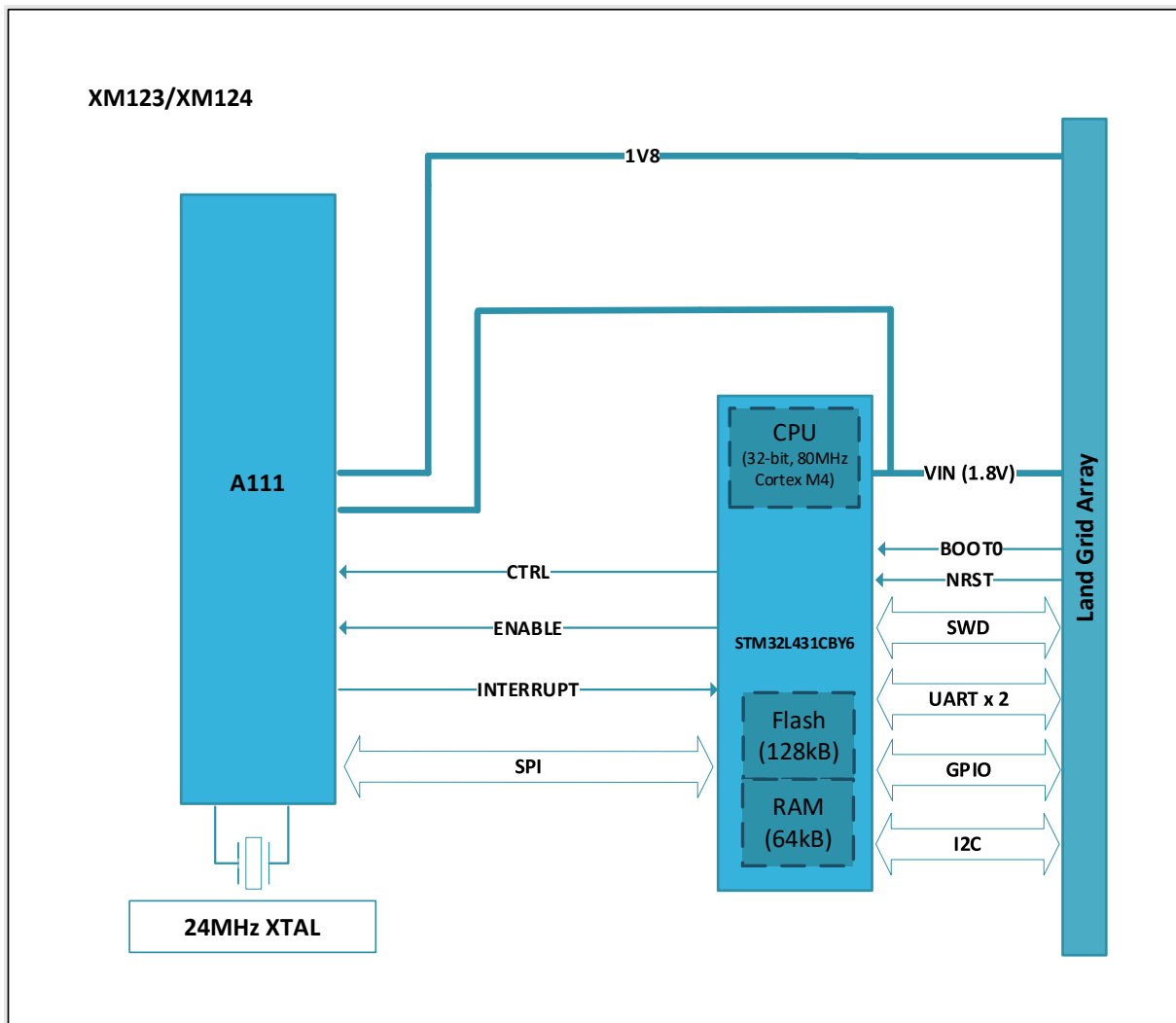

Figure 2.2. XM124/XM123 block diagram.

The XM124/XM123 block diagram shows the A111 60 GHz PCR radar connected to the M4 microcontroller. The module provides Land Grid Array pads where the MCU external I/F are accessible including single voltage supply.

2.4 Module board Land Grid Array description

Figure 2.3 shows the XM124 (XM123 module is similar) module front and back side pin markings. Table 1 shows the module pinout.

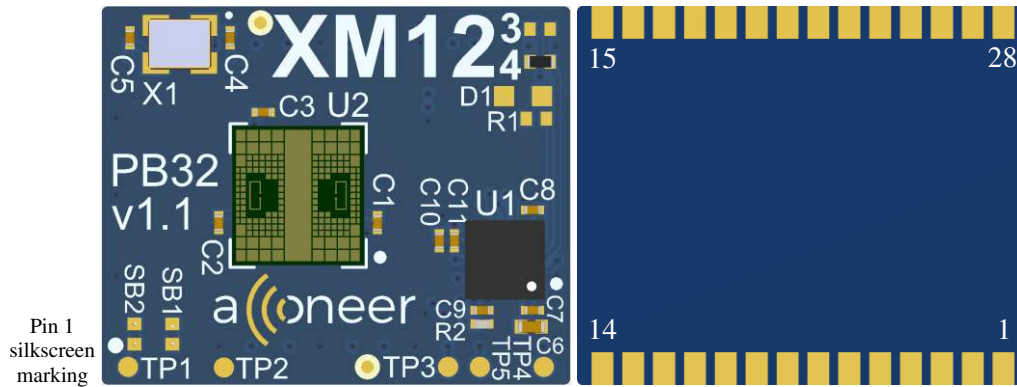

Figure 2.3. XM124 front and back side.

Table 1. XM123/XM124 LGA pinout.

Pin Number	Signal	Comment
1	VIN	1.8 V input voltage
2	Ground	
3	1V8	1.8 V input voltage
4	Ground	
5	UART_TX	Connect to UART_RX on host side. Leave Not Connected if unused.
6	UART_RX	Connect to UART_TX on host side. Leave Not Connected if unused.
7	Ground	
8	UART_CTS	Connect to UART_RTS on host side. Leave Not Connected if unused.
9	UART_RTS	Connect to UART_CTS on host side. Leave Not Connected if unused.
10	Ground	
11	SWD_IO	Leave Not Connected if unused.
12	SWD_CLK	Leave Not Connected if unused.
13	Ground	
14	NRESET	Reset. Leave Not Connected if unused.
15	WAKE_UP	Could be used by host to wake up XM124/XM123 MCU. Leave Not Connected if unused.
16	Ground	
17	I2C_SCL	Leave Not Connected if unused.
18	I2C_SDA	Leave Not Connected if unused.
19	Ground	
20	I2C_ADDRESS	For configuration of I2C address. Leave Not Connected if unused.
21	DEBUG_UART_RX	Connect to UART_TX on host side. Leave Not Connected if unused.



22	Ground	
23	DEBUG_UART_TX	Connect to UART_RX on host side. Leave Not Connected if unused.
24	MISC_GPIO0	Leave Not Connected if unused.
25	MISC_GPIO1	Leave Not Connected if unused.
26	MISC_GPIO2_BOOT0	Pulling BOOT0 high during boot of module will start the embedded boot loader. Leave Not Connected if unused.
27	Ground	
28	MCU_INT	Could be used to send interrupt from MCU to host. Leave Not Connected if unused.



2.5 Software options

The XM123/XM124 modules can be used in two regimes:

- **Stand-alone module:** The module operates as an independent system. The application is customized to a specific use case by the customer and runs on the embedded MCU. The customer application is accessing the RSS API.
- **Controlled module:** The module is connected to an external host where the customer runs their application software. The customers are accessing the RSS API via a hardware interface through the module server, that provides register command protocol. The module output is either detector output data or service radar data through the XM123/XM124 external interfaces such as UART and I2C.

As a stand-alone module the Acconeer SDK provides RSS, hardware abstraction layer, device drivers and build system. It is also possible for the customer to develop their own application and both the RSS and applications runs on the embedded MCU.

Using as a controlled module Acconeer provides SW images including RSS and module server application that provides hardware interface accessing the RSS API through a register command protocol, see ref [3].

For further software information, see XM124/XM123 Entry+ Module Evaluation Kit User guide, ref [2].



3 Interfaces

3.1 Module supply input

Both modules support a 1.8 V external single power supply, see Table 3 on recommended operating conditions. The power supply ripple specification of A111 VIO3 must be fulfilled for the “VIN” voltage to XM123/XM124. Refer to A111 datasheet, chapter 9.2 for details, ref [1].

Note that supply voltage conditions (e.g. slew rate) need to be taken into consideration according to STM M4 microcontroller datasheet, ref [5].

3.2 System functions

The Entry+ Module XM124 and the Entry+ Module XM123 supports system power states, see XM124/XM123 Module Software User guide, Ref [3] for further information.

Module RESET is supported by activating NRST pin (active low).

3.3 Serial interfaces

The Entry+ Module XM124 and the Entry+ Module XM123 GPIO pins can be configured to support up to two UARTs, the communication UART and a debug UART. The main UART has support for flow control. The XM124/XM123 supports I2C compatible 2-wire master/slave external serial interface, see Table 1. See also STM M4 microcontroller datasheet, ref [5] for further information.

The XM124/XM123 has JTAG/SWD interface for debugging and flashing.

3.4 I/O interfaces

The Entry+ Module XM124 and the Entry+ Module XM123 supports three General Purpose IOs (GPIOs), MISC_GPIO0, MISC_GPIO1 and MISC_GPIO2_BOOT0. The GPIO pins are configurable for different functions, only the debug and RESET pins are fixed to specific GPIOs, see Table 1. See also STM M4 microcontroller datasheet, ref [5] for further information.

The XM124/XM123 has a wake-up pin (WAKE_UP) which can be used to wake up the module.

3.5 Module reset

The Entry+ Module XM124 and the Entry+ Module XM123 has an external reset option (Pin 14 on the XM124/XM123).



4 Electrical specifications

4.1 Absolute maximum ratings

Table 2 shows the absolute maximum ratings over operating temperature range, unless otherwise noted.

Table 2. Absolute maximum ratings.

Parameter	Description	Min.	Max.	Unit
VIN, 1.8 V	power supply	-0.3	2	V
I/O	Voltage on I/O pins	-0.3	2	V
T _{OP}	Operating temperature range	-40	85	°C
T _{STG}	High temperature storage		125	°C

Stresses beyond those listed in Table 2 may cause permanent damage to the device. These are stress ratings only and functional operation of the device at these conditions or at any other conditions beyond those indicated under Recommended Operating Conditions is not implied. Exposure to absolute-maximum-rated conditions for extended periods of time may affect device reliability.

4.2 Recommended operating conditions

Table 3. Recommended operating conditions.

Parameter	Min.	Typ.	Max.	Unit
VIN, 1.8 V operating power supply voltage	1.71		1.89	V
I/O operating range	0		VIN+0.3	V
Operating temperature	-40		85	°C



4.3 Power consumption summary

Table 4 gives the power consumption and the idle current at $T_A = 25^\circ\text{C}$, 1.8 V supply, external power switch on VIO1 and VIO2 used.

Table 4. Power consumption and idle current.

Parameter	Min.	Typ.	Max.	Unit
Measurement range: 1.0 m, 0.1 Hz update rate, sensor off		0.044 ⁽¹⁾		mW
Measurement range: 2.5 m, 20 Hz update rate, sensor hibernate		8.16 ⁽¹⁾		mW
Idle current		6.65 ⁽²⁾		uA

¹Configuration with Sparse service, profile 3 used.

²STM M4 microcontroller is in sleep mode (Stop Mode 1) with full RAM retention and wake-up on RTC enabled.

Figure 4.1 gives the current profile for measurement range 1.0m.

Figure 4.1. Current profile, measurement range 1.0m.

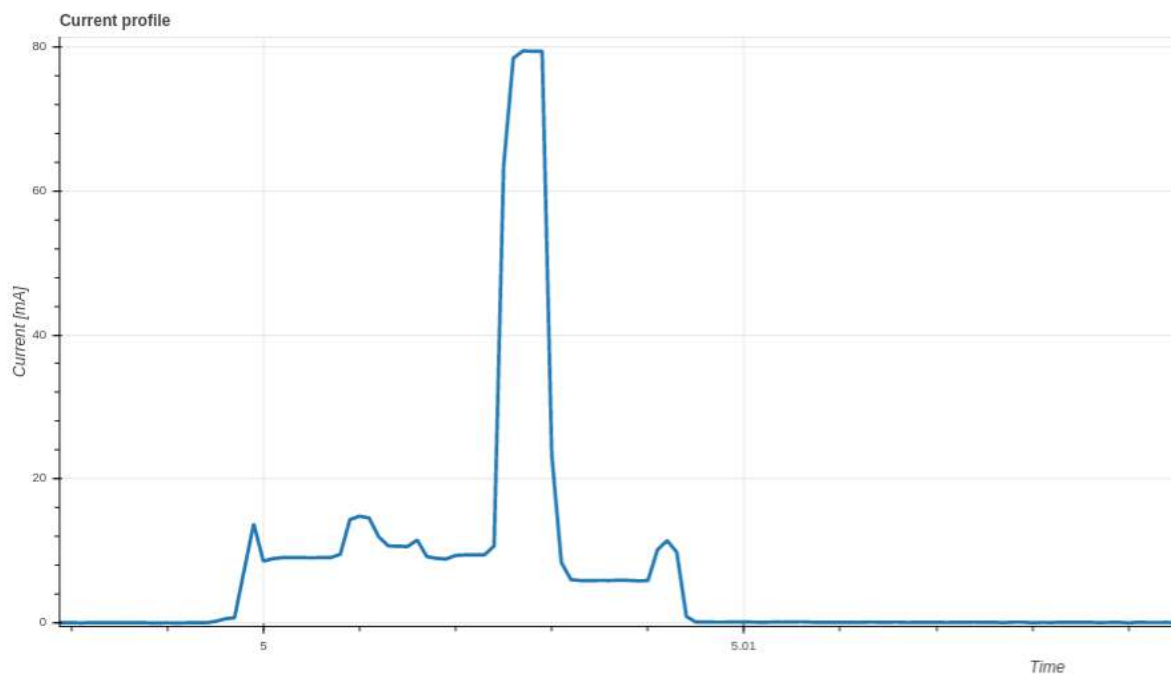

4.4 RF specification

The module RF specification is given in Table 5.

Table 5. XM123/XM124 RF specification.

Parameter	Min.	Typ.	Max.	Unit
Simulated Tx half power beamwidth, E-plane		55		degrees
Simulated Tx half power beamwidth, H-plane		64		degrees



4.5 Typical characteristics, Radar Loop Gain pattern

The Radar Loop Gain (RLG) pattern includes the gain in both the TX and RX radar paths and is defined as the angular separation between the two points at which the gain has decreased by 3 dB relative to the maximum main lobe value, when the radar itself is used to measure the reflected power.

Conditions: $T_A = 25\text{ }^\circ\text{C}$. Tested on 5 XM124/XM123 devices.

Figure 4.2 shows the RLG radiation pattern normalized to free space sensor boresight at elevation plane (E-plane) and azimuth plane (H-plane).

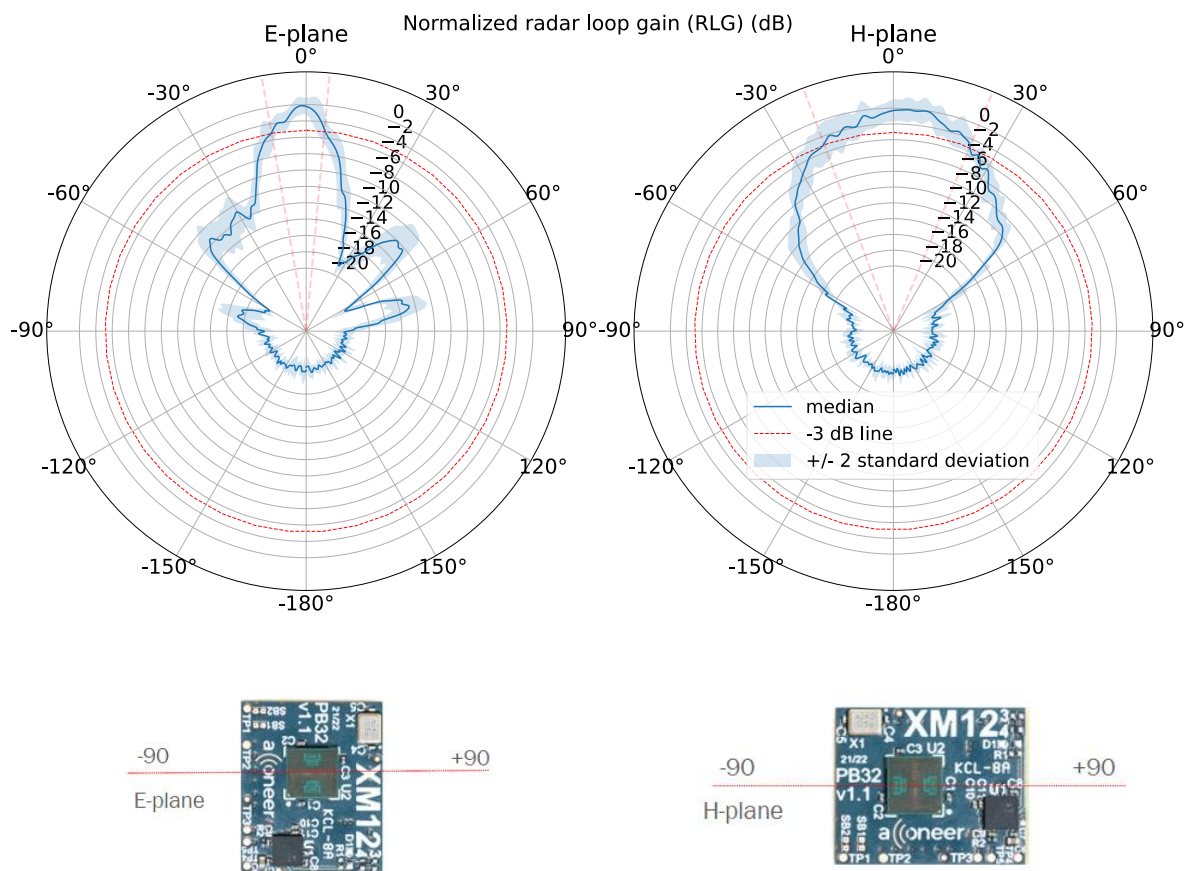

Figure 4.2. Radar Loop Gain (RLG) radiation patterns (normalized)



5 Reference design description

5.1 Schematics & BOM

The following pages include the module schematics and bill of materials.

THIS DOCUMENT AND THE DATA DISCLOSED HEREIN OR HEREWITH IS CONFIDENTIAL AND THE PROPERTY OF ACCONEER AB.

MCU

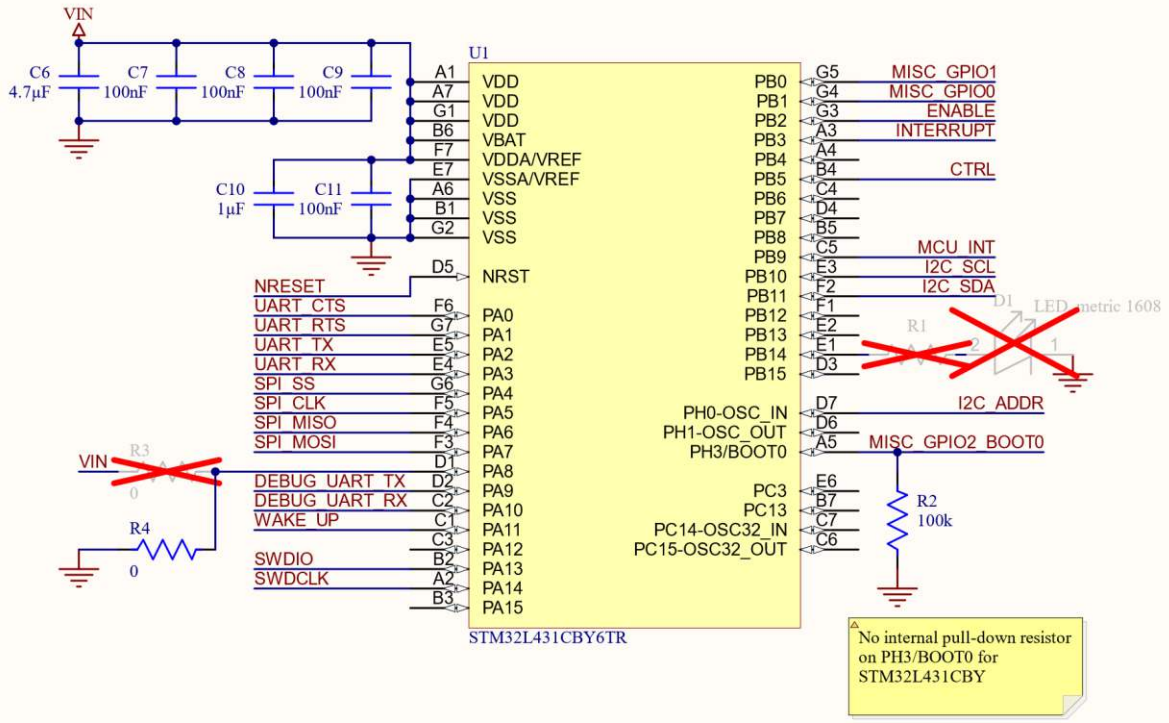

Radar sensor

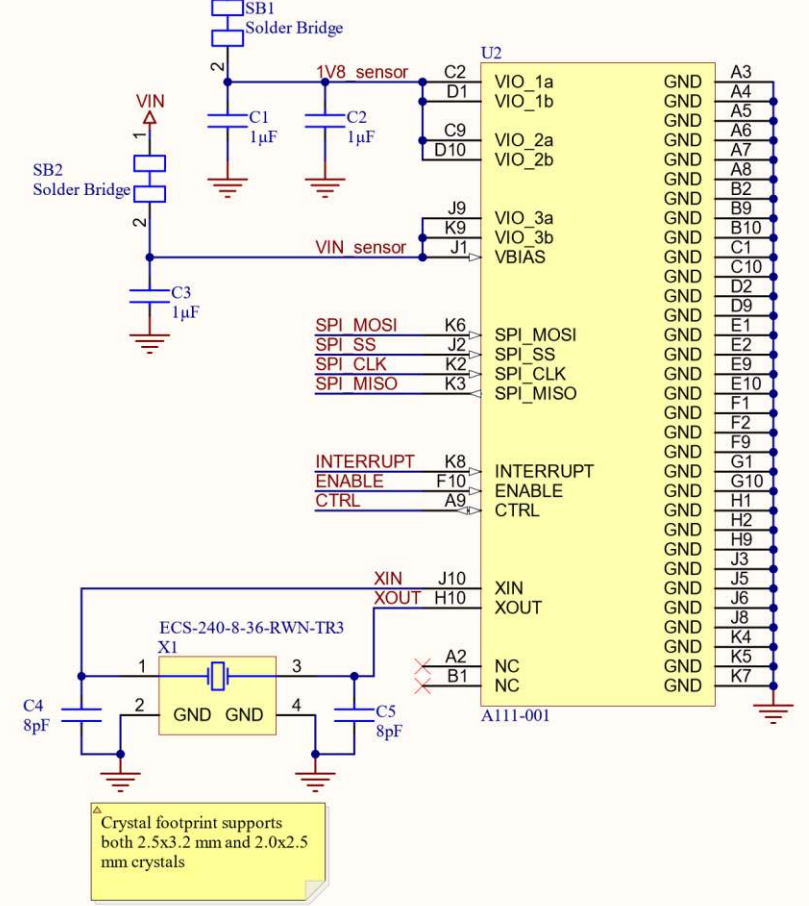

Module LGA footprint

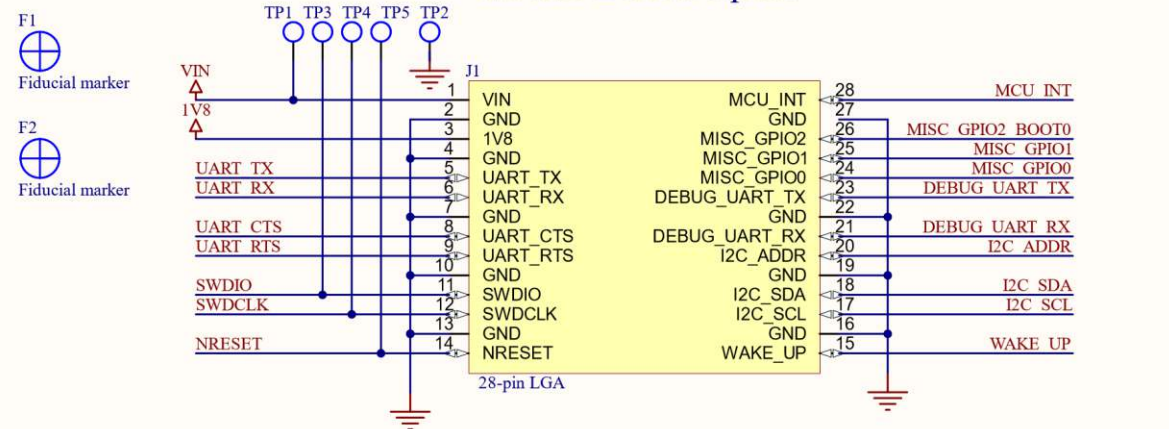

Title		XM123/XM124 module		aconeer	
Size	Project variant	PB number	PCBA version		
A4	XM124	PB32			
Date:	2022-07-22	Sheet 1 of 1			
File:	XM123_XM124.SchDoc	Drawn By:	Jonas Langbacka		



Bill of Material

Table 6. Bill of materials (BOM).

Component Ref.	Specification	QTY	Value	Comment
C1, C2, C3, C10	Capacitor 1 uF, metric 0603	4	1 μ F	
C4, C5	Capacitor 8 pF, metric 0603	2	8 pF	
C6	Capacitor 4.7uF, metric 1005	1	4.7 μ F	
C7, C8, C9, C11	Capacitor 100nF, metric 1005	4	100 nF	
R2	Resistor 100 kOhm, metric 0603	1	100 kOhm	
R4	Resistor 0 Ohm, metric 1005	1	0 Ohm	
U1	MCU STM32L431CBY6 32-bit WLCSP49	1		ST Microelectronics: STM32L431CBY6
U2	Radar Sensor 60 GHz A111	1		Acconeer AB: A111
X1	Crystal 24MHz 9 pF 4-Pin SMD	1	24 MHz	ECS-240-8-36-RWN- TR3



6 Mechanical specifications and footprint

XM123/XM124 mechanical dimensions are given in Figure 6.1 (top view) and Figure 6.2 (bottom view). Figure 6.3 shows the recommended footprint of XM123/XM124.

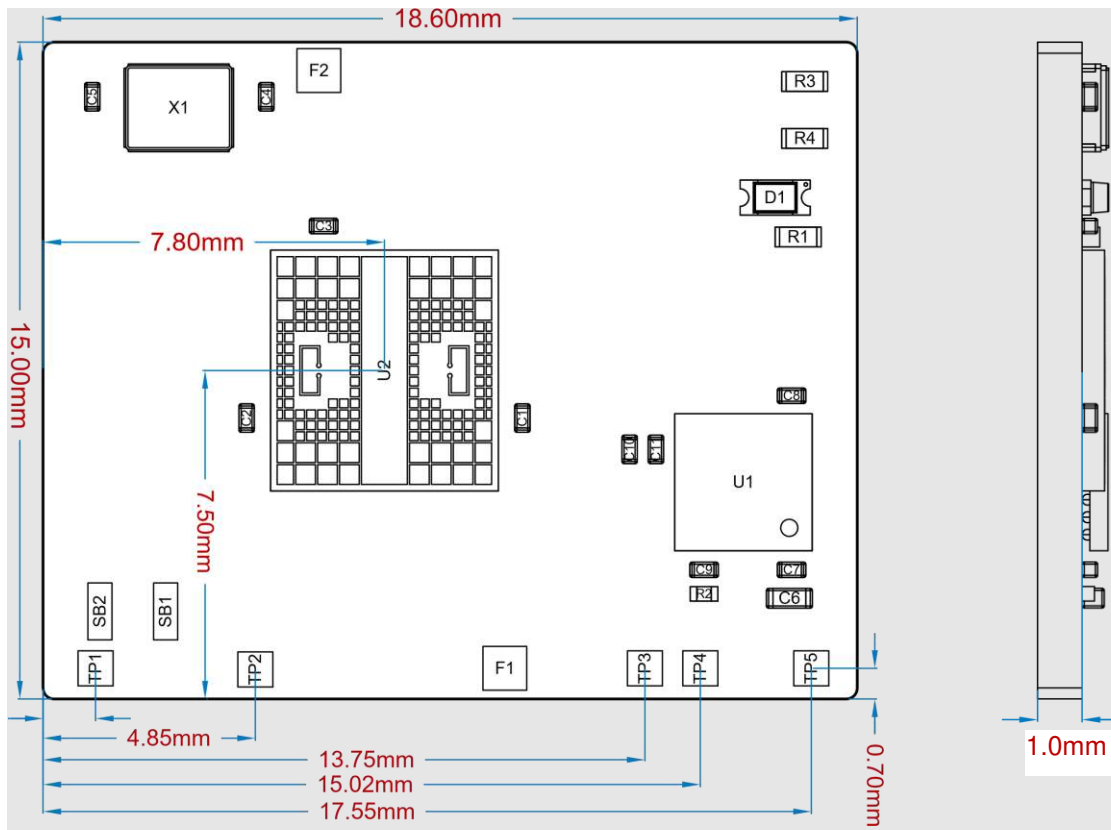

Figure 6.1. XM123/XM124 top view.

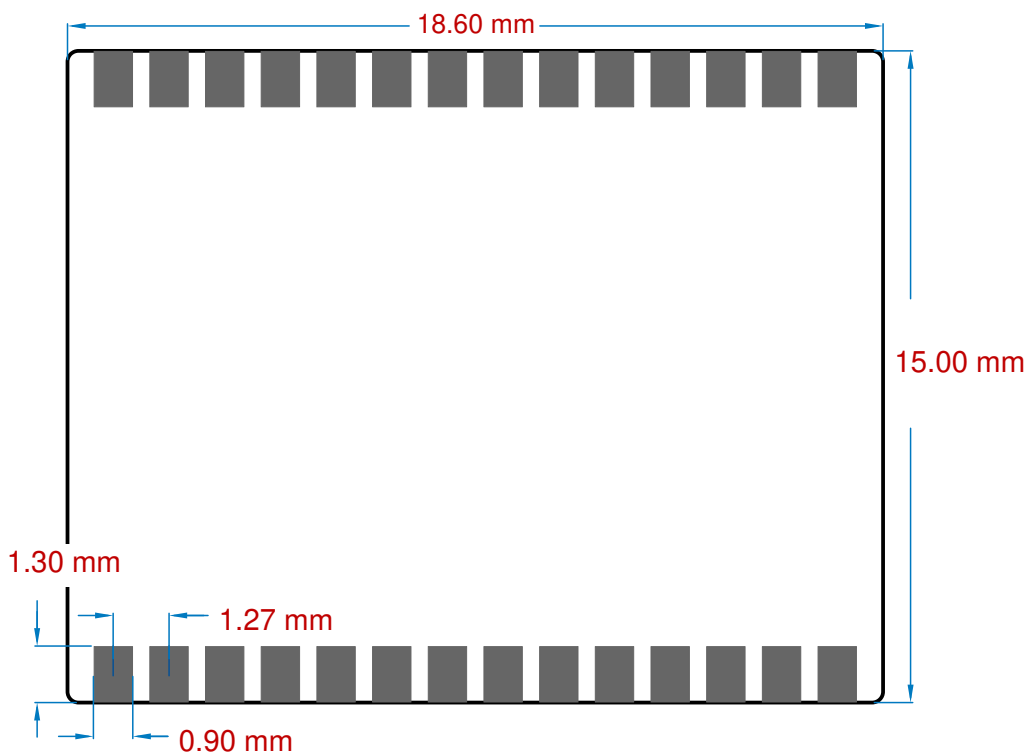

Figure 6.2. XM123/XM124 bottom view.

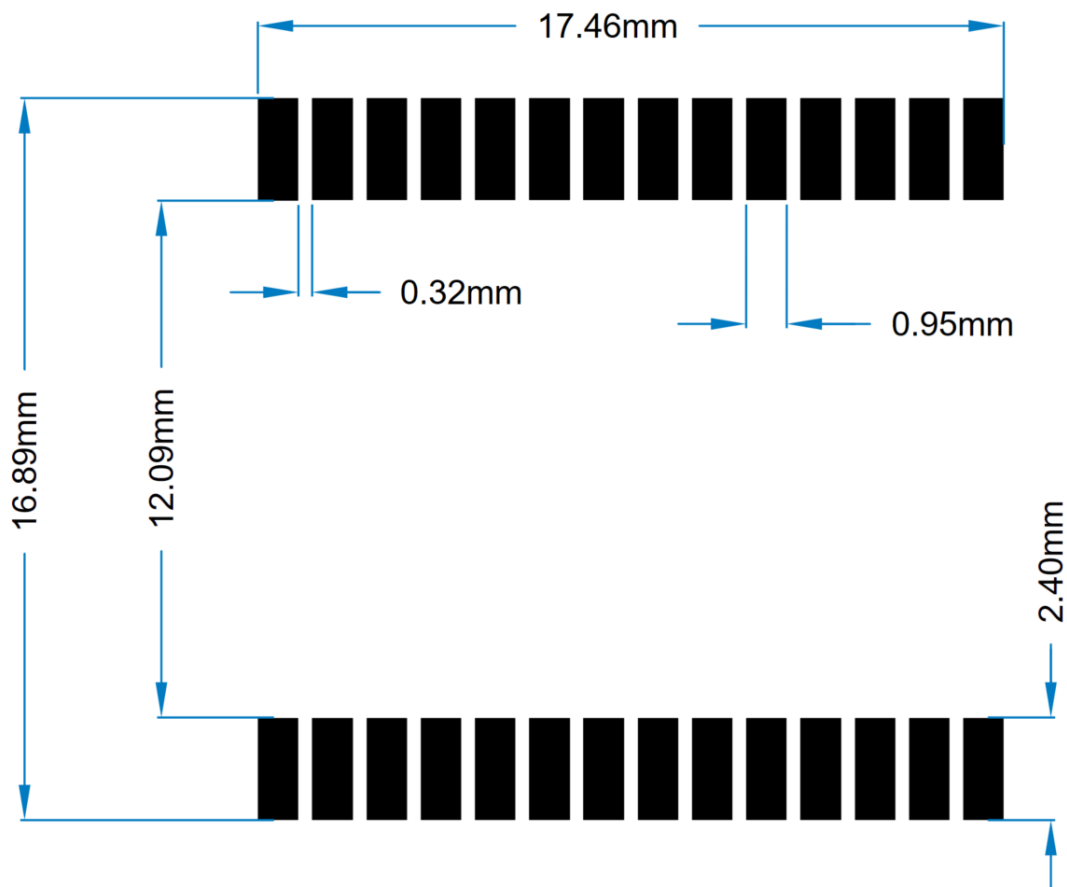

Figure 6.3. XM123/XM124 recommended footprint.

6.1 Moisture Sensitivity Level and Recommended Reflow Profile

XM123/XM124 modules are moisture sensitive and need to be handled within proper Moisture Sensitive Level 3 (MSL3) guidelines to avoid damage from moisture absorption and exposure to solder reflow temperatures that can result in yield and reliability degradation.

Refer to IPC/JEDEC J-STD-033D for details regarding Handling, Packing, Shipping and Use of Moisture, Reflow, and Process Sensitive Devices.

XM123/XM124 is baked and dry-packed before shipment from Acconeer AB according to MSL3.

Maximum number of reflow passes recommended for XM124/XM123 is one (1).

It is recommended to use a reflow profile compatible with the IPC/JEDEC J-STD-020E classification profile.

6.2 RoHS and REACH Statement

The XM123 and XM124 meet the requirements of Directive 2011/65/EC of the European Parliament and of the Council on the Restriction of Hazardous Substances (RoHS) and the requirements of the REACH regulation (EC 1907/2006) on Registration, Evaluation, Authorization and Restriction of Chemicals.



7 Regulatory Approval

To be noted is that some regulatory specifications also specify usage of the module, so users of the module must check regulatory requirements for their own use case and determine if the regulatory approvals described below are sufficient.

7.1 ETSI

XM124/XM123 is compliant to EU safety, health and environmental requirements (CE marked). The A111 sensor is compliant with directive 2014/53/EU, see A111 datasheet ref. [1].

7.2 FCC Approval

XM124/XM123 is compliant to 47 CFR part 15 unintentional emitter Class B. The A111 sensor has modular approval granted by FCC, see A111 datasheet ref. [1].



8 Reference documents

- [1] A111 Pulsed Coherent Radar (PCR) Datasheet:
<https://developer.acconeer.com/>
- [2] Entry+ Module XM124 Evaluation Kit, User guide
<https://developer.acconeer.com/>
- [3] XM124/XM123 Module Software User guide
<https://developer.acconeer.com/>
- [4] XE124 Evaluation board, Product brief
<https://developer.acconeer.com/>
- [5] MCU STM32L431CBY6 Datasheet:
[STM Semiconductor](https://www.st.com/en/microcontrollers-and-mcu/stm32l431cby6.html)
- [6] Hardware and physical integration guideline
<https://developer.acconeer.com/>



9 Abbreviations

AiP	Antenna in Package
API	Application Programming Interface
BOM	Bill of Materials
EIRP	Equivalent Isotropically Radiated Power
GND	Ground
GPIO	General Purpose Input/Output
HPBW	Half Power Beamwidth
HW	HardWare
I2C	Inter-Integrated Circuit
LGA	Land Grid Array
MCU	MicroController Unit
NVM	Non-Volatile Memory
PCR	Pulse Coherent Radar
RLG	Radar Loop Gain
RF	Radio Frequency
RSS	Radar System Software
SDK	Software Development Kit
SoC	System on Chip
SPI	Serial Peripheral Interface
SW	SoftWare
SWD	Serial Wire Debug
UART	Universal Asynchronous Receiver/Transmitter



Disclaimer

The information herein is believed to be correct as of the date issued. Acconeer AB (“**Acconeer**”) will not be responsible for damages of any nature resulting from the use or reliance upon the information contained herein. Acconeer makes no warranties, expressed or implied, of merchantability or fitness for a particular purpose or course of performance or usage of trade. Therefore, it is the user’s responsibility to thoroughly test the product in their particular application to determine its performance, efficacy and safety. Users should obtain the latest relevant information before placing orders.

Unless Acconeer has explicitly designated an individual Acconeer product as meeting the requirement of a particular industry standard, Acconeer is not responsible for any failure to meet such industry standard requirements.

Unless explicitly stated herein this document Acconeer has not performed any regulatory conformity test. It is the user’s responsibility to assure that necessary regulatory conditions are met and approvals have been obtained when using the product. Regardless of whether the product has passed any conformity test, this document does not constitute any regulatory approval of the user’s product or application using Acconeer’s product.

Nothing contained herein is to be considered as permission or a recommendation to infringe any patent or any other intellectual property right. No license, express or implied, to any intellectual property right is granted by Acconeer herein.

Acconeer reserves the right to at any time correct, change, amend, enhance, modify, and improve this document and/or Acconeer products without notice.

This document supersedes and replaces all information supplied prior to the publication hereof.

© 2023 by Acconeer – All rights reserved



Acconeer AB
Västra Varvsgatan 19
211 77 MALMÖ
Sweden

www.acconeer.com
info@acconeer.com
+46 10 218 92 00