



# STEVAL-ISV013V1

## 250 W DC-DC solar module demonstration board for distributed photovoltaic architecture

Data brief

### Features

- Input voltage range from 10 V to 45 V
- Output voltage range from 350 V to 430 V
- Digital control section managed by the STM32
- Several I/O connectors to be connected to the photovoltaic panel (input side) and the inverter (output side)
- Ready to be connected to a PLM or ZigBee® external module for communication
- Possibility to meter and monitor the status of the panel
- Fire and anti-theft protections
- RoHS compliant

### Description

The STEVAL-ISV013V1 demonstration board is a fully integrated module designed for a smart junction box in distributed photovoltaic architecture. The module represents an easy-to-use, fully-protected solution to implement precise photovoltaic panel control, diagnostics and protection.

The STEVAL-ISV013V1 demonstration board is the base element for a new photovoltaic panel configuration able to increase the panel energy produced and to simplify the photovoltaic field design and implementation. Furthermore, the maintenance cost will be reduced as the device is able to monitor the status of the individual panels and to communicate these data to a remote control unit. The STEVAL-ISV013V1 demonstration board uses an isolated converter, which is the input of the panel output. This voltage is stepped up to the voltage defined by the inverter, needed to create a sinusoidal output with a magnitude big enough to transfer energy to the grid.

The module features an embedded MPPT (maximum power point tracking) algorithm based on the “perturb and observe” (P&O) technique to

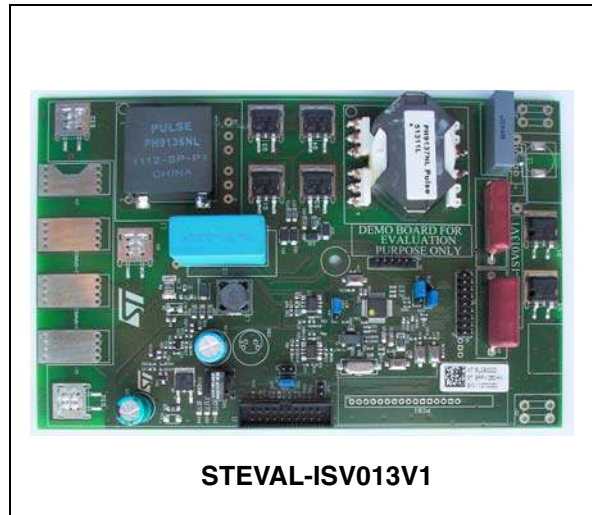

search for the best operating point of the panel in order to maximize the energy produced in every environmental condition.

The module is internally protected from a surge or lightning reaching the connection wires.

The STEVAL-ISV013V1 demonstration board includes a PLM or ZigBee® module for communication. The PLM is supported by a proprietary protocol stack for networking. A gateway to RS485 in modbus is available. The unit is designed to operate in a harsh environment, offering a high level of protection and very high reliability.

The ZigBee® module is based on system-on-chip (SoC) technology, integrating both IEEE 802.15.4 radio transceiver and computing capabilities and is designed to run a fully compliant ZigBee® PRO network protocol stack.

# 1 Schematic circuit

Figure 1. Isolated full-bridge boost converter

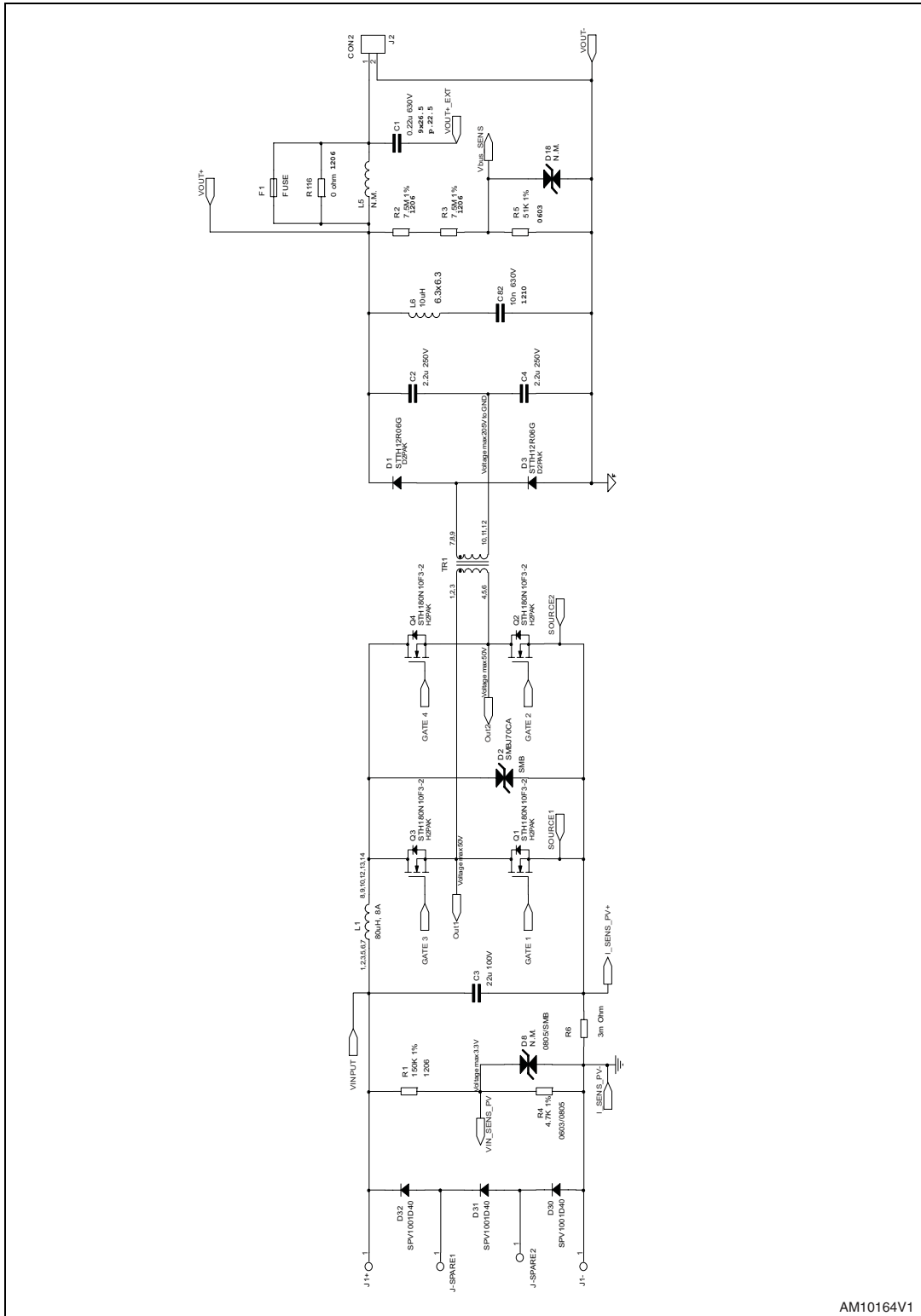

AM10164V1

Figure 2. Auxiliary power supply

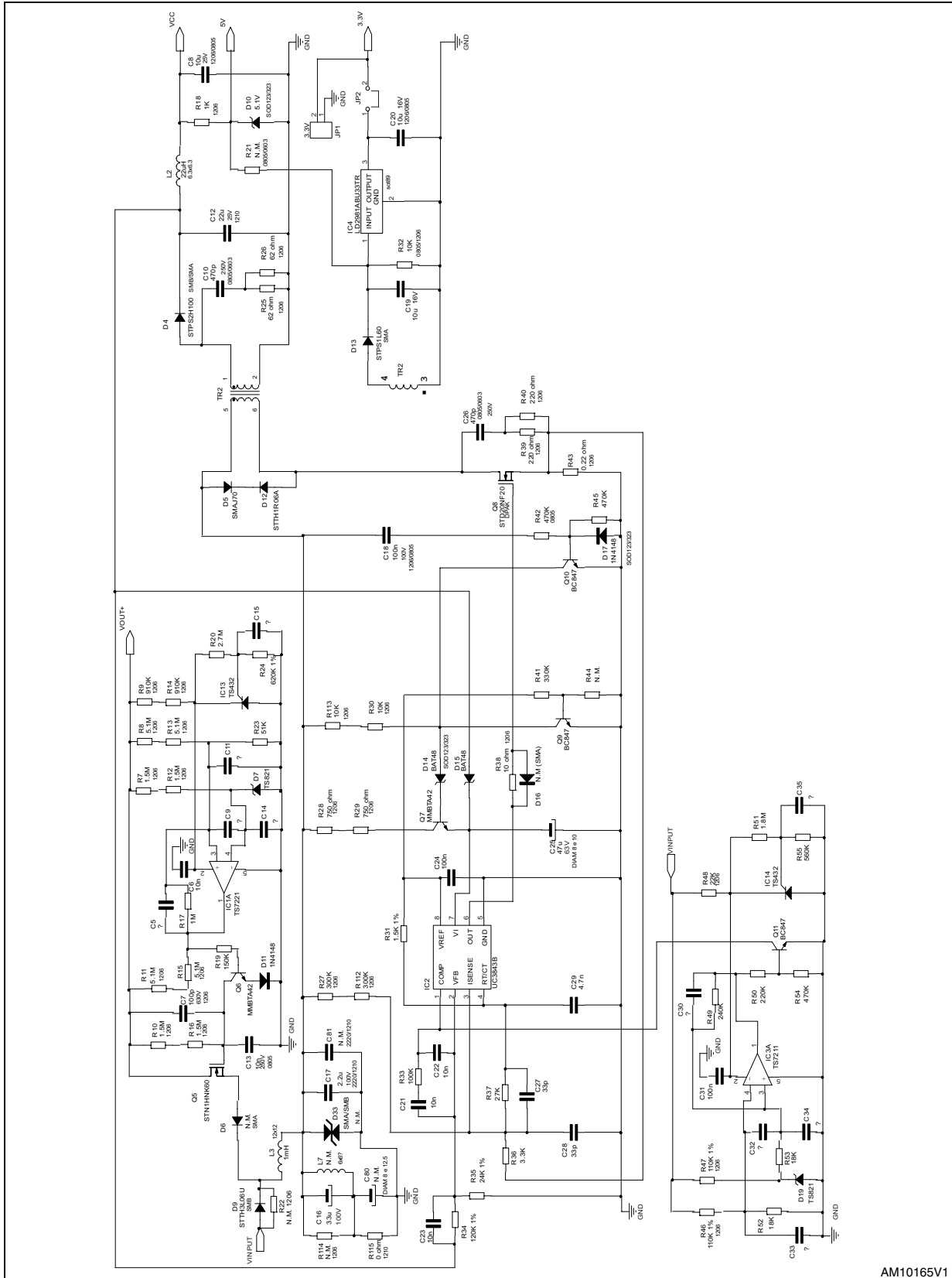

AM10165V1



## 2 Revision history

**Table 1. Document revision history**

Date	Revision	Changes
07-Sep-2011	1	Initial release.

**Please Read Carefully:**

Information in this document is provided solely in connection with ST products. STMicroelectronics NV and its subsidiaries ("ST") reserve the right to make changes, corrections, modifications or improvements, to this document, and the products and services described herein at any time, without notice.

All ST products are sold pursuant to ST's terms and conditions of sale.

Purchasers are solely responsible for the choice, selection and use of the ST products and services described herein, and ST assumes no liability whatsoever relating to the choice, selection or use of the ST products and services described herein.

No license, express or implied, by estoppel or otherwise, to any intellectual property rights is granted under this document. If any part of this document refers to any third party products or services it shall not be deemed a license grant by ST for the use of such third party products or services, or any intellectual property contained therein or considered as a warranty covering the use in any manner whatsoever of such third party products or services or any intellectual property contained therein.

**UNLESS OTHERWISE SET FORTH IN ST'S TERMS AND CONDITIONS OF SALE ST DISCLAIMS ANY EXPRESS OR IMPLIED WARRANTY WITH RESPECT TO THE USE AND/OR SALE OF ST PRODUCTS INCLUDING WITHOUT LIMITATION IMPLIED WARRANTIES OF MERCHANTABILITY, FITNESS FOR A PARTICULAR PURPOSE (AND THEIR EQUIVALENTS UNDER THE LAWS OF ANY JURISDICTION), OR INFRINGEMENT OF ANY PATENT, COPYRIGHT OR OTHER INTELLECTUAL PROPERTY RIGHT.**

**UNLESS EXPRESSLY APPROVED IN WRITING BY TWO AUTHORIZED ST REPRESENTATIVES, ST PRODUCTS ARE NOT RECOMMENDED, AUTHORIZED OR WARRANTED FOR USE IN MILITARY, AIR CRAFT, SPACE, LIFE SAVING, OR LIFE SUSTAINING APPLICATIONS, NOR IN PRODUCTS OR SYSTEMS WHERE FAILURE OR MALFUNCTION MAY RESULT IN PERSONAL INJURY, DEATH, OR SEVERE PROPERTY OR ENVIRONMENTAL DAMAGE. ST PRODUCTS WHICH ARE NOT SPECIFIED AS "AUTOMOTIVE GRADE" MAY ONLY BE USED IN AUTOMOTIVE APPLICATIONS AT USER'S OWN RISK.**

Resale of ST products with provisions different from the statements and/or technical features set forth in this document shall immediately void any warranty granted by ST for the ST product or service described herein and shall not create or extend in any manner whatsoever, any liability of ST.

ST and the ST logo are trademarks or registered trademarks of ST in various countries.

Information in this document supersedes and replaces all information previously supplied.

The ST logo is a registered trademark of STMicroelectronics. All other names are the property of their respective owners.

© 2011 STMicroelectronics - All rights reserved

STMicroelectronics group of companies

Australia - Belgium - Brazil - Canada - China - Czech Republic - Finland - France - Germany - Hong Kong - India - Israel - Italy - Japan - Malaysia - Malta - Morocco - Philippines - Singapore - Spain - Sweden - Switzerland - United Kingdom - United States of America

[www.st.com](http://www.st.com)