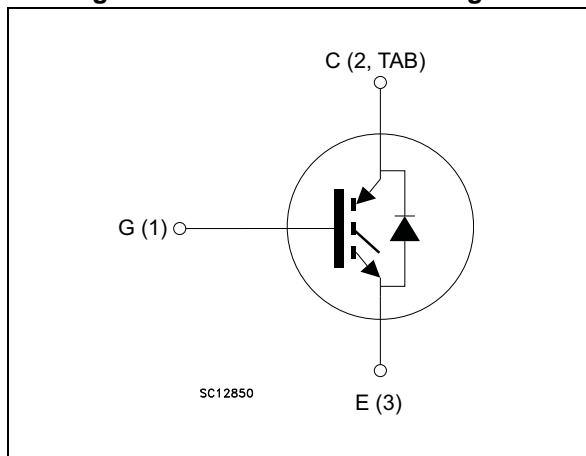

Figure 1. Internal schematic diagram



### Features

- High speed switching
- Tight parameters distribution
- Safe paralleling
- Low thermal resistance
- Short-circuit rated
- Ultrafast soft recovery antiparallel diode

### Applications

- Motor control
- UPS, PFC

### Description

This device is an IGBT developed using an advanced proprietary trench gate and field stop structure. This IGBT series offers the optimum compromise between conduction and switching losses, maximizing the efficiency of very high frequency converters. Furthermore, a positive  $V_{CE(sat)}$  temperature coefficient and very tight parameter distribution result in easier paralleling operation.

Table 1. Device summary

Order codes	Marking	Packages	Packaging
STGB7H60DF	GB7H60DF	D <sup>2</sup> PAK	Tape and reel
STGF7H60DF	GF7H60DF	TO-220FP	Tube
STGP7H60DF	GP7H60DF	TO-220	Tube

# Contents

<b>1</b>	<b>Electrical ratings</b> .....	<b>3</b>
<b>2</b>	<b>Electrical characteristics</b> .....	<b>4</b>
2.1	Electrical characteristics (curves) .....	7
<b>3</b>	<b>Test circuits</b> .....	<b>14</b>
<b>4</b>	<b>Package information</b> .....	<b>15</b>
4.1	D <sup>2</sup> PAK package information .....	15
4.2	D <sup>2</sup> PAK packing information .....	18
4.3	TO-220FP package information .....	20
4.4	TO-220 package information .....	22
<b>5</b>	<b>Revision history</b> .....	<b>24</b>

# 1 Electrical ratings

**Table 2. Absolute maximum ratings**

Symbol	Parameter	TO-220 D <sup>2</sup> PAK	TO-220FP	Unit
$V_{CES}$	Collector-emitter voltage ( $V_{GE} = 0$ )	600		V
$I_C$	Continuous collector current at $T_C = 25\text{ °C}$	14	14 <sup>(1)</sup>	A
	Continuous collector current at $T_C = 100\text{ °C}$	7	7 <sup>(1)</sup>	
$I_{CP}^{(2)}$	Pulsed collector current	28	28 <sup>(1)</sup>	A
$V_{GE}$	Gate-emitter voltage	±20		V
$I_F$	Continuous forward current $T_C = 25\text{ °C}$	14	14 <sup>(1)</sup>	A
	Continuous forward current at $T_C = 100\text{ °C}$	7	7 <sup>(1)</sup>	
$I_{FP}^{(2)}$	Pulsed forward current	28	28 <sup>(1)</sup>	A
$V_{ISO}$	Insulation withstand voltage (RMS) from all three leads to external heat sink ( $t = 1\text{ s}$ , $T_C = 25\text{ °C}$ )		2500	V
$P_{TOT}$	Total dissipation at $T_C = 25\text{ °C}$	88	24	W
$T_{STG}$	Storage temperature range	- 55 to 150		°C
$T_J$	Operating junction temperature	- 55 to 175		

1. Limited by maximum junction temperature.
2. Pulse width limited by maximum junction temperature.

**Table 3. Thermal data**

Symbol	Parameter	TO-220 D <sup>2</sup> PAK	TO-220FP	Unit
$R_{thJC}$	Thermal resistance junction-case IGBT	1.7	6.2	°C/W
$R_{thJC}$	Thermal resistance junction-case diode	2.8	6.25	°C/W
$R_{thJA}$	Thermal resistance junction-ambient	62.5		°C/W

## 2 Electrical characteristics

$T_J = 25\text{ °C}$  unless otherwise specified.

**Table 4. Static**

Symbol	Parameter	Test conditions	Min.	Typ.	Max.	Unit
$V_{(BR)CES}$	Collector-emitter breakdown voltage ( $V_{GE} = 0\text{ V}$ )	$I_C = 2\text{ mA}$	600			V
$V_{CE(sat)}$	Collector-emitter saturation voltage	$V_{GE} = 15\text{ V}, I_C = 7\text{ A}$		1.5	1.95	V
		$V_{GE} = 15\text{ V}, I_C = 7\text{ A}$ $T_J = 125\text{ °C}$		1.6		
		$V_{GE} = 15\text{ V}, I_C = 7\text{ A}$ $T_J = 175\text{ °C}$		1.7		
$V_{GE(th)}$	Gate threshold voltage	$V_{CE} = V_{GE}, I_C = 250\text{ }\mu\text{A}$	4.8	6.2	6.9	V
$I_{CES}$	Collector cut-off current ( $V_{GE} = 0\text{ V}$ )	$V_{CE} = 600\text{ V}$			25	$\mu\text{A}$
$I_{GES}$	Gate-emitter leakage current ( $V_{CE} = 0\text{ V}$ )	$V_{GE} = \pm 20\text{ V}$			250	nA

**Table 5. Dynamic**

Symbol	Parameter	Test conditions	Min.	Typ.	Max.	Unit
$C_{ies}$	Input capacitance	$V_{CE} = 25\text{ V}, f = 1\text{ MHz},$ $V_{GE} = 0\text{ V}$	-	1050	-	pF
$C_{oes}$	Output capacitance		-	51	-	
$C_{res}$	Reverse transfer capacitance		-	23	-	
$Q_g$	Total gate charge	$V_{CC} = 480\text{ V}, I_C = 7\text{ A},$ $V_{GE} = 15\text{ V}$	-	46	-	nC
$Q_{ge}$	Gate-emitter charge		-	7	-	
$Q_{gc}$	Gate-collector charge		-	21	-	

Table 6. Switching characteristics (inductive load)

Symbol	Parameter	Test conditions	Min.	Typ.	Max.	Unit
$t_{d(on)}$	Turn-on delay time	$V_{CE} = 400\text{ V}$ , $I_C = 7\text{ A}$ , $R_G = 47\ \Omega$ , $V_{GE} = 15\text{ V}$	-	30	-	ns
$t_r$	Current rise time		-	12.2	-	ns
$(di/dt)_{on}$	Turn-on current slope		-	459	-	A/ $\mu$ s
$t_{d(on)}$	Turn-on delay time	$V_{CE} = 400\text{ V}$ , $I_C = 7\text{ A}$ , $R_G = 47\ \Omega$ , $V_{GE} = 15\text{ V}$ $T_J = 175\text{ }^\circ\text{C}$	-	30	-	ns
$t_r$	Current rise time		-	12.8	-	ns
$(di/dt)_{on}$	Turn-on current slope		-	440	-	A/ $\mu$ s
$t_{r(Voff)}$	Off voltage rise time	$V_{CE} = 400\text{ V}$ , $I_C = 7\text{ A}$ , $R_G = 47\ \Omega$ , $V_{GE} = 15\text{ V}$	-	24	-	ns
$t_{d(off)}$	Turn-off delay time		-	160	-	
$t_f$	Current fall time		-	69	-	
$t_{r(Voff)}$	Off voltage rise time	$V_{CE} = 400\text{ V}$ , $I_C = 7\text{ A}$ , $R_G = 47\ \Omega$ , $V_{GE} = 15\text{ V}$ $T_J = 175\text{ }^\circ\text{C}$	-	31	-	ns
$t_{d(off)}$	Turn-off delay time		-	164	-	
$t_f$	Current fall time		-	99	-	
$t_{sc}$	Short-circuit withstand time	$V_{CC} \leq 360\text{ V}$ , $V_{GE} = 15\text{ V}$ , $R_G = 47\ \Omega$	-	5	-	$\mu$ s

Table 7. Switching energy (inductive load)

Symbol	Parameter	Test conditions	Min.	Typ.	Max.	Unit
$E_{on}^{(1)}$	Turn-on switching losses	$V_{CE} = 400\text{ V}$ , $I_C = 7\text{ A}$ , $R_G = 47\ \Omega$ , $V_{GE} = 15\text{ V}$	-	99	-	$\mu$ J
$E_{off}^{(2)}$	Turn-off switching losses		-	100	-	
$E_{ts}$	Total switching losses		-	199	-	
$E_{on}^{(1)}$	Turn-on switching losses	$V_{CE} = 400\text{ V}$ , $I_C = 7\text{ A}$ , $R_G = 47\ \Omega$ , $V_{GE} = 15\text{ V}$ $T_J = 175\text{ }^\circ\text{C}$	-	202	-	$\mu$ J
$E_{off}^{(2)}$	Turn-off switching losses		-	149	-	
$E_{ts}$	Total switching losses		-	351	-	

1. Energy losses include reverse recovery of the diode.
2. Turn-off losses include also the tail of the collector current.

Table 8. Collector-emitter diode

Symbol	Parameter	Test conditions	Min.	Typ.	Max.	Unit
$V_F$	Forward on-voltage	$I_F = 7 \text{ A}$	-	1.5	2.1	V
		$I_F = 7 \text{ A}, T_J = 175 \text{ }^\circ\text{C}$		1.15		
$t_{rr}$	Reverse recovery time	$V_{CC} = 400 \text{ V}; I_F = 7 \text{ A};$ $di_F/dt = 100 \text{ A}/\mu\text{s}$	-	136		ns
$Q_{rr}$	Reverse recovery charge		-	104		nC
$I_{rrm}$	Reverse recovery current		-	2.25		A
$t_{rr}$	Reverse recovery time	$V_{CC} = 400 \text{ V}; I_F = 7 \text{ A};$ $di_F/dt = 100 \text{ A}/\mu\text{s}$ $T_J = 175 \text{ }^\circ\text{C}$	-	154		ns
$Q_{rr}$	Reverse recovery charge		-	388		nC
$I_{rrm}$	Reverse recovery current		-	4.6		A

## 2.1 Electrical characteristics (curves)

Figure 2. Power dissipation vs. case temperature for D<sup>2</sup>PAK and TO-220

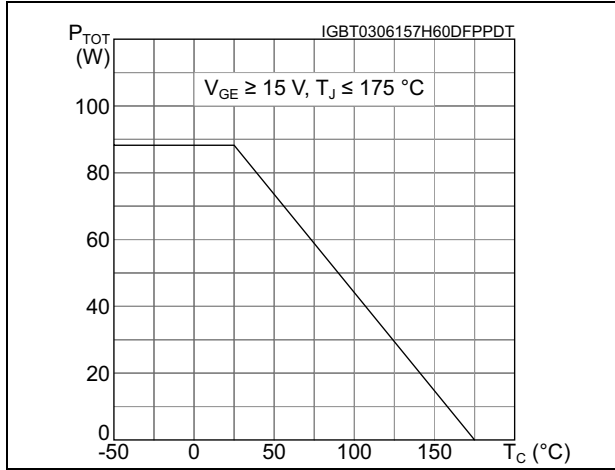

Figure 3. Collector current vs. case temperature for D<sup>2</sup>PAK and TO-220

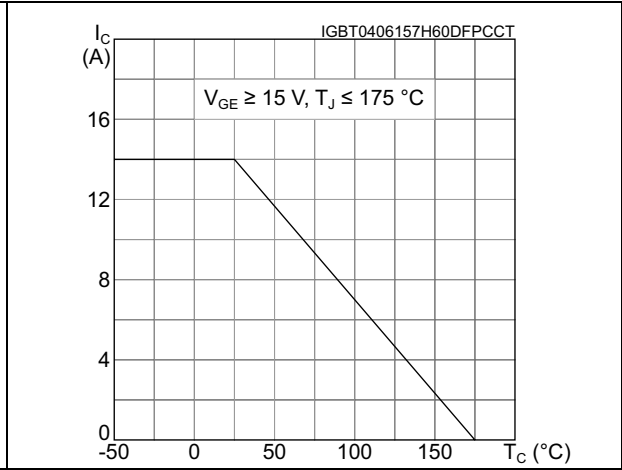

Figure 4. Power dissipation vs. case temperature for TO-220FP

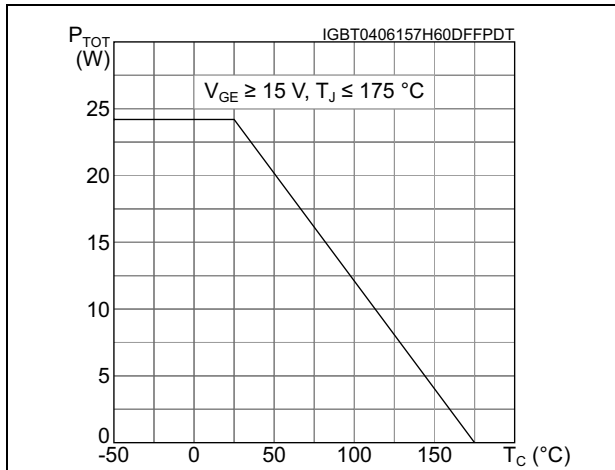

Figure 5. Collector current vs. case temperature for TO-220FP

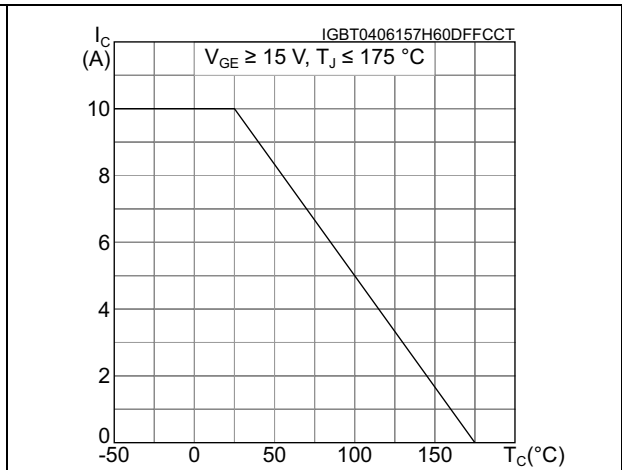

Figure 6. Output characteristics ( $T_J = 25^\circ\text{C}$ )

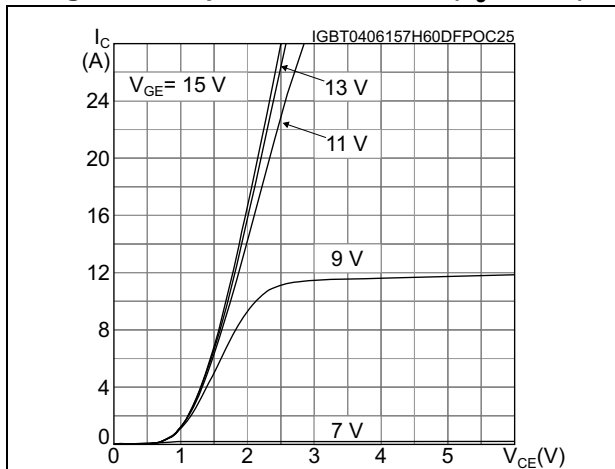

Figure 7. Output characteristics ( $T_J = 175^\circ\text{C}$ )

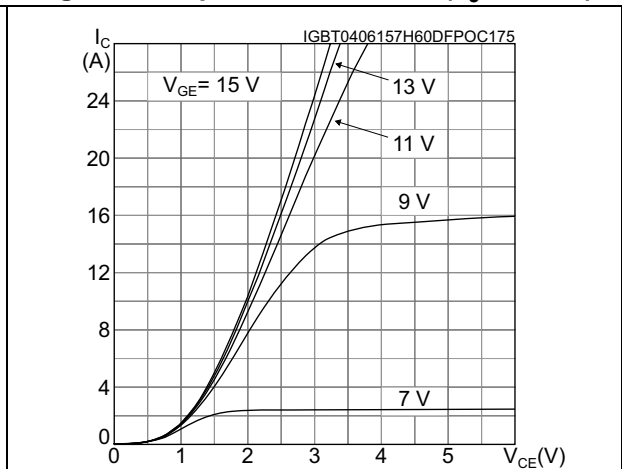

Figure 8.  $V_{CE(sat)}$  vs. junction temperature

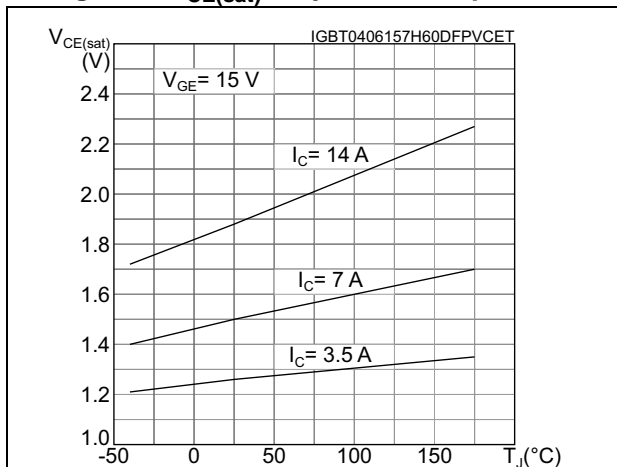

Figure 9.  $V_{CE(sat)}$  vs. collector current

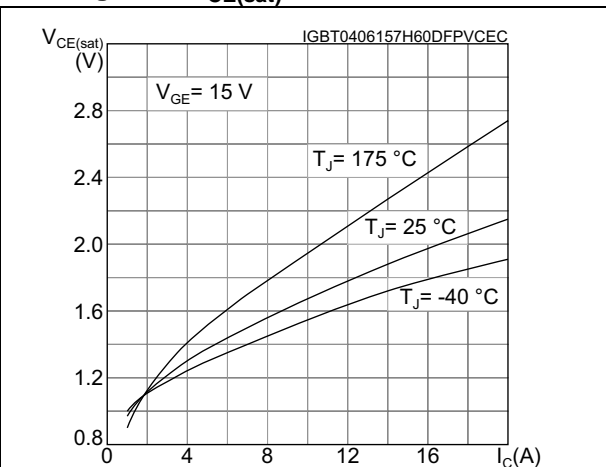

Figure 10. Collector current vs. switching frequency for D<sup>2</sup>PAK and TO-220

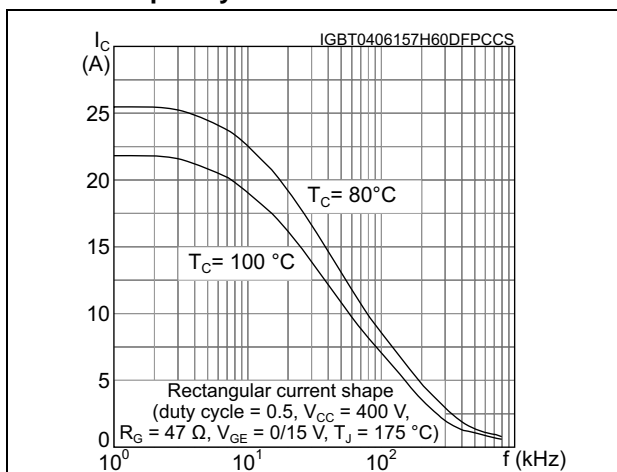

Figure 11. Collector current vs. switching frequency for TO-220FP

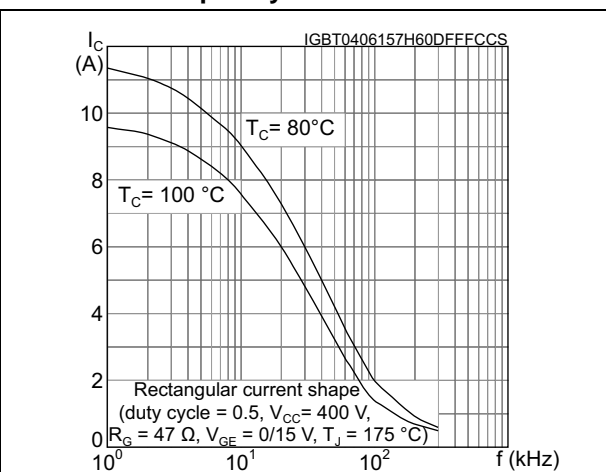

Figure 12. Forward bias safe operating area for D<sup>2</sup>PAK and TO-220

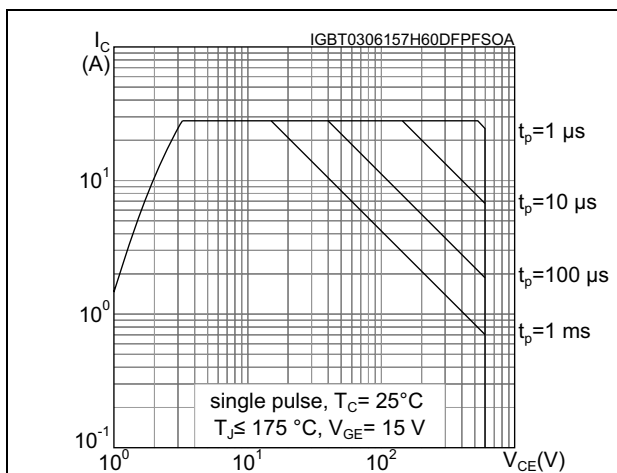

Figure 13. Forward bias safe operating area for TO-220FP

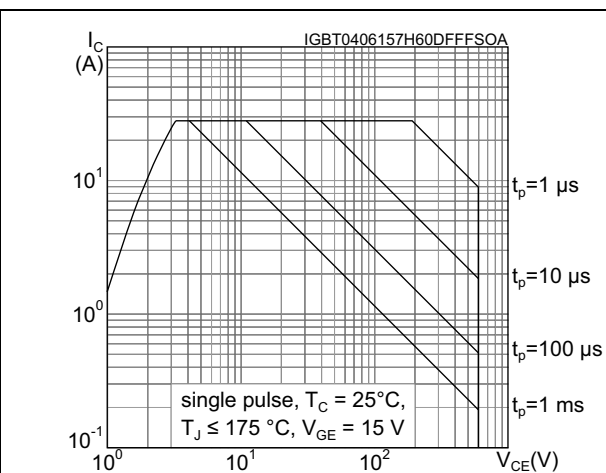



Figure 14. Transfer characteristics

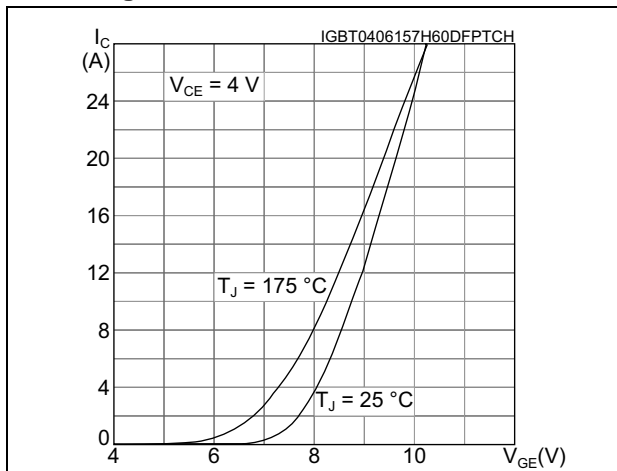

Figure 15. Diode  $V_F$  vs. forward current

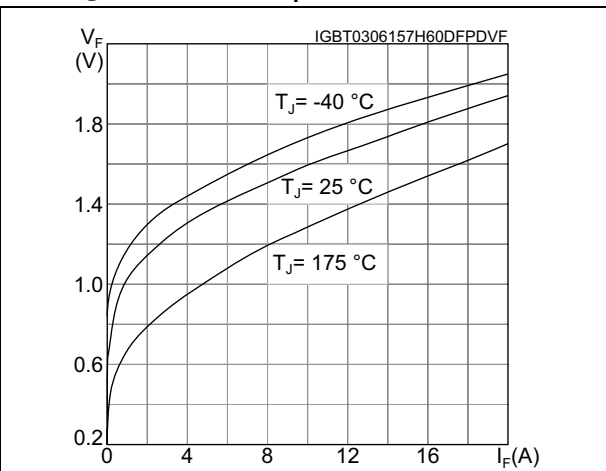

Figure 16. Normalized  $V_{GE(th)}$  vs. junction temperature

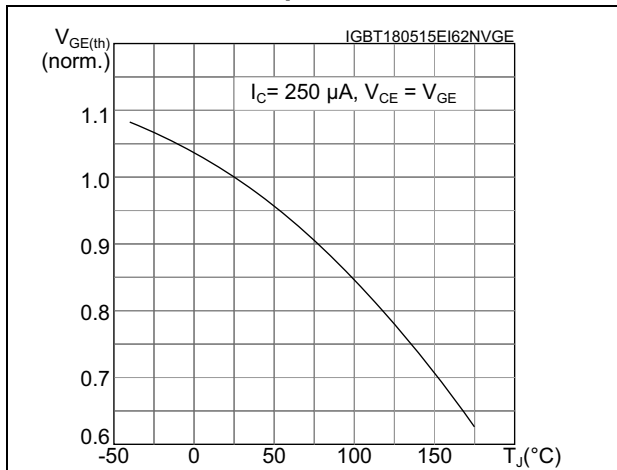

Figure 17. Normalized  $V_{BR(CES)}$  vs. junction temperature

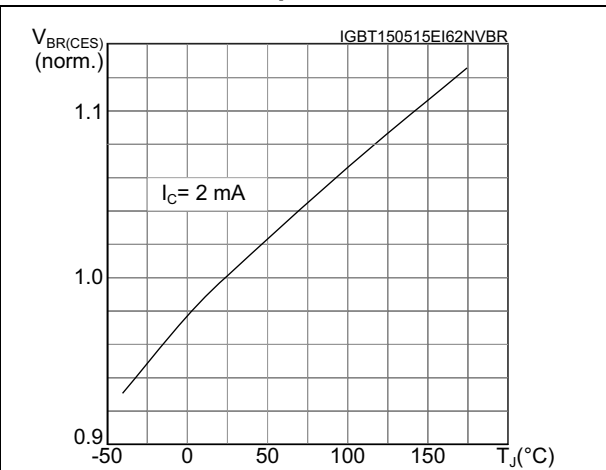

Figure 18. Capacitance variation

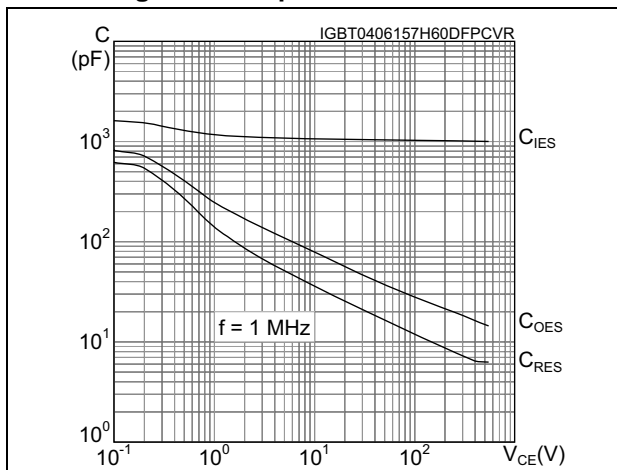

Figure 19. Gate charge vs. gate-emitter voltage

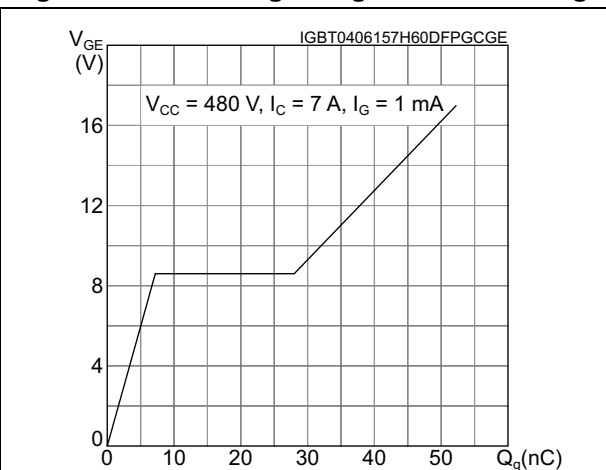

Figure 20. Switching loss vs. collector current

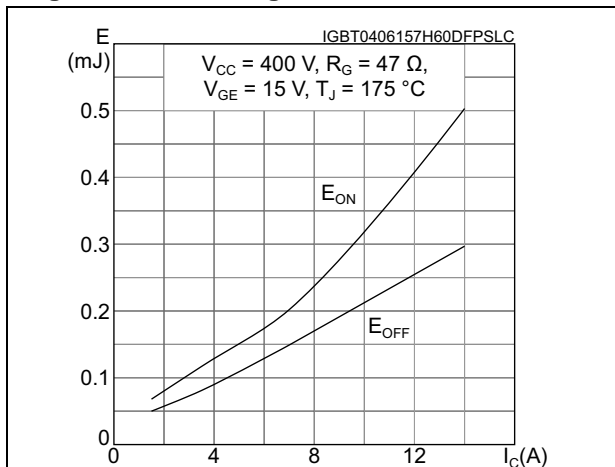

Figure 21. Switching loss vs. gate resistance

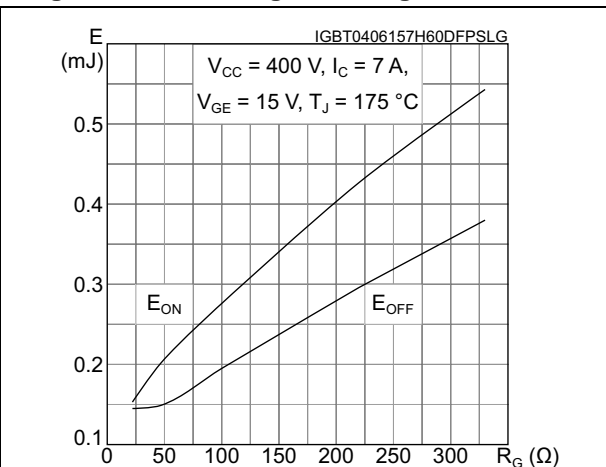

Figure 22. Switching loss vs. temperature

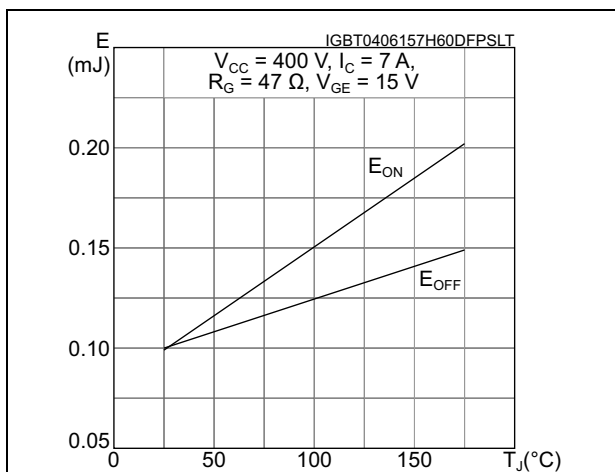

Figure 23. Switching loss vs. collector-emitter voltage

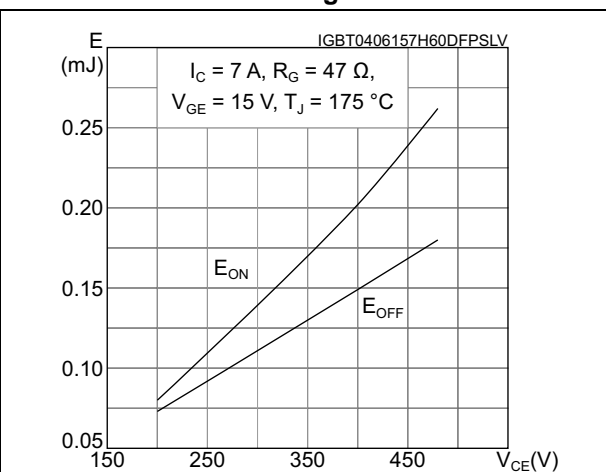

Figure 24. Short circuit time and current vs. Vge

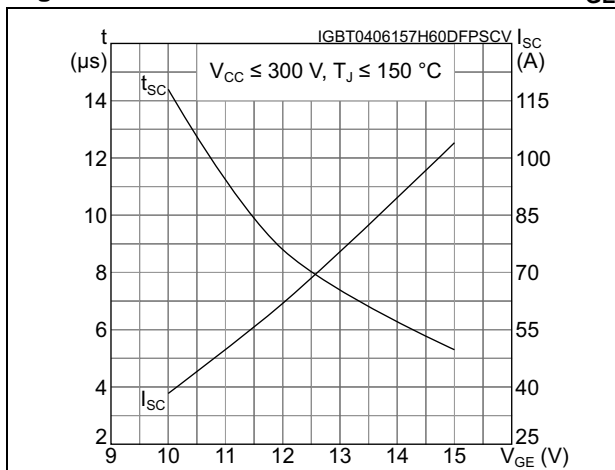

Figure 25. Switching times vs. collector current

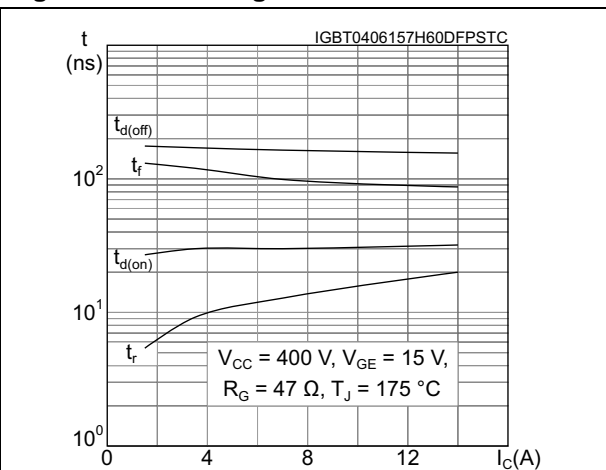

Figure 26. Switching times vs. gate resistance

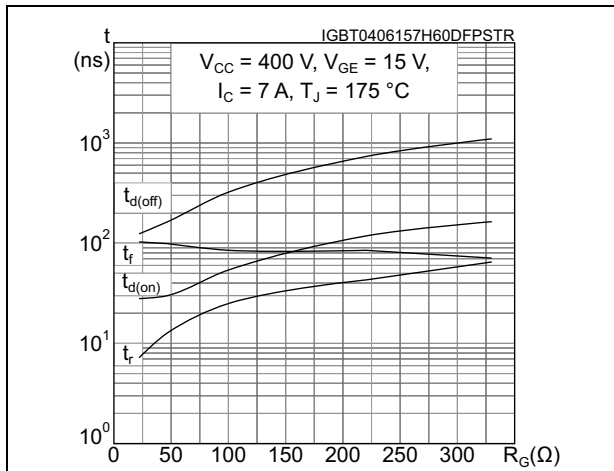

Figure 27. Reverse recovery current vs. diode current slope

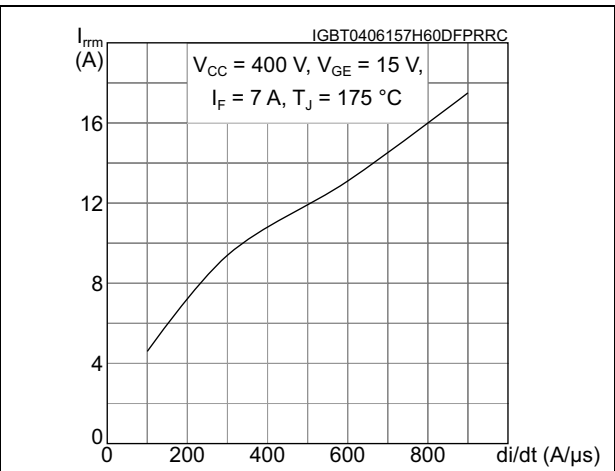

Figure 28. Reverse recovery time vs. diode current slope

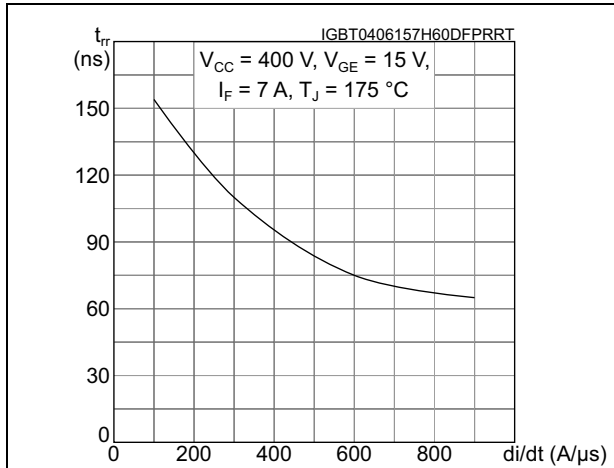

Figure 29. Reverse recovery charge vs. diode current slope

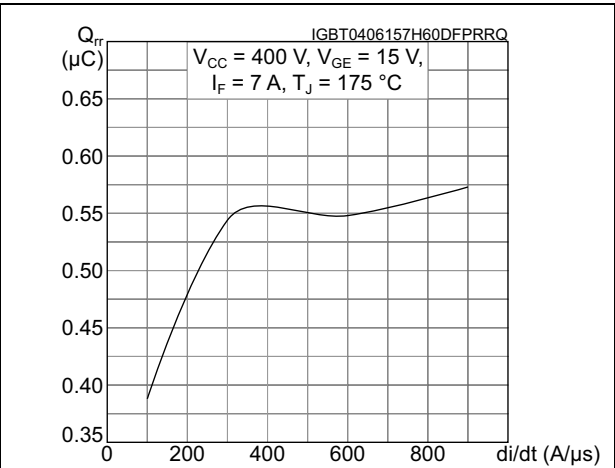

Figure 30. Reverse recovery energy vs. diode current slope

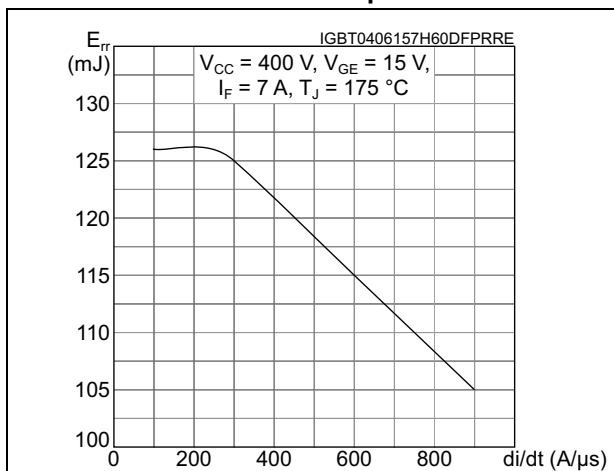

Figure 31. Thermal impedance for D<sup>2</sup>PAK and TO-220 IGBT

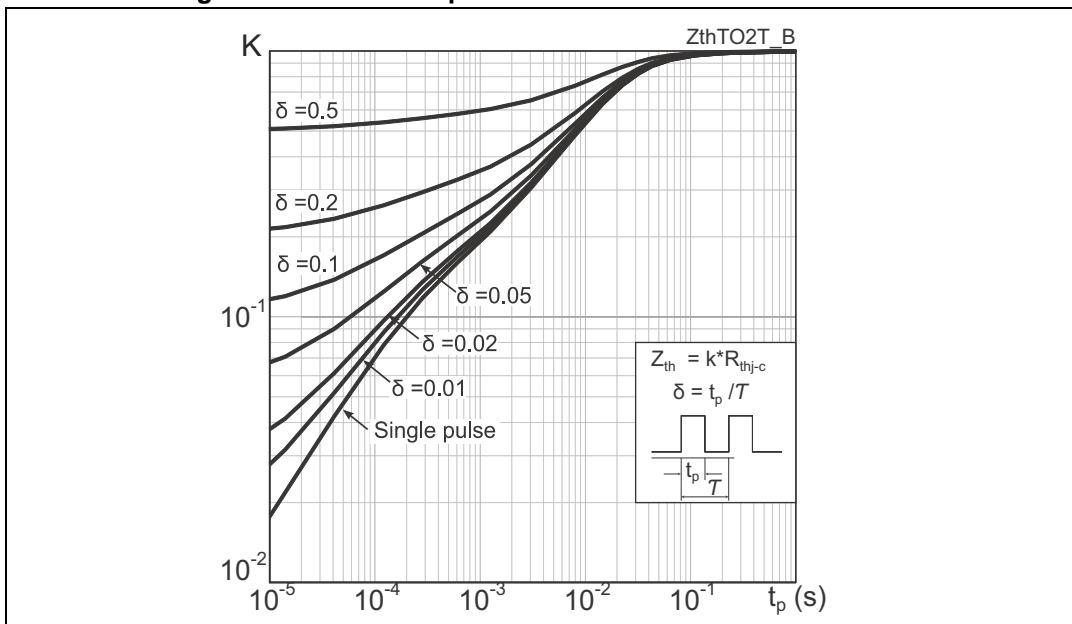

Figure 32. Thermal impedance for D<sup>2</sup>PAK and TO-220 diode

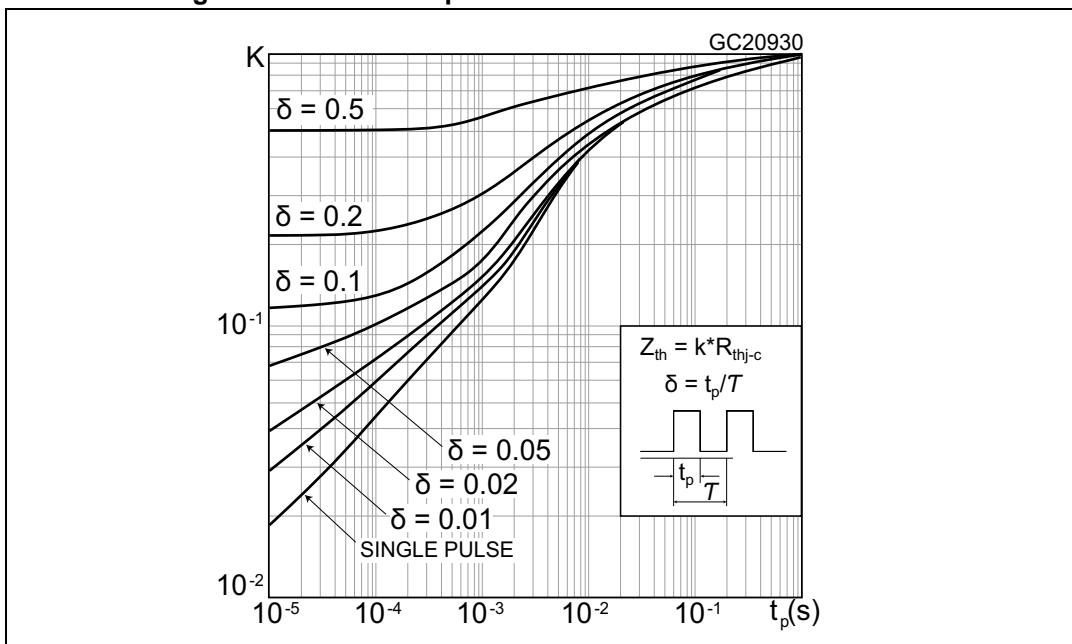

Figure 33. Thermal impedance for TO-220FP IGBT

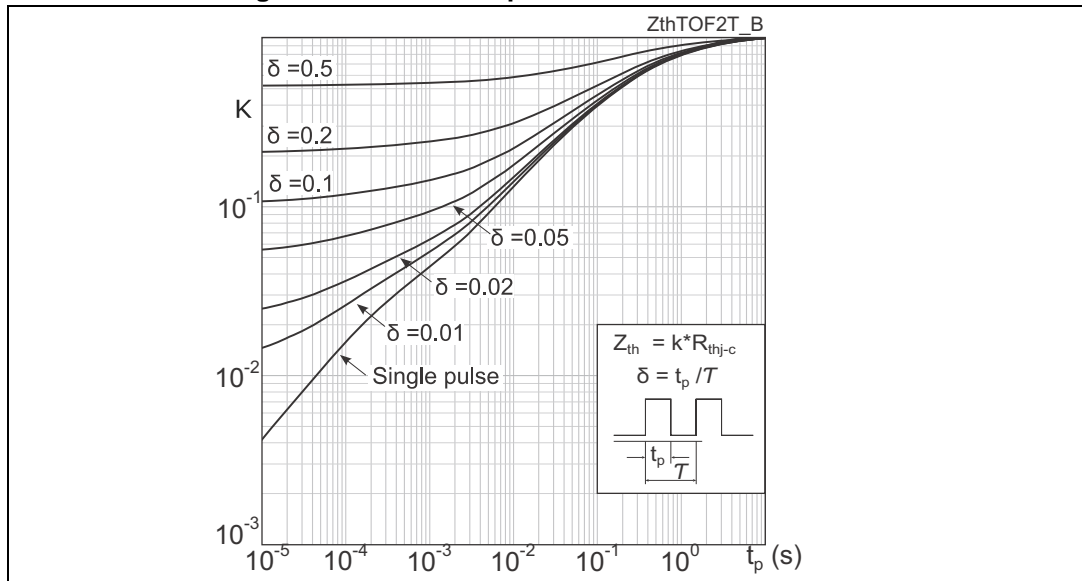
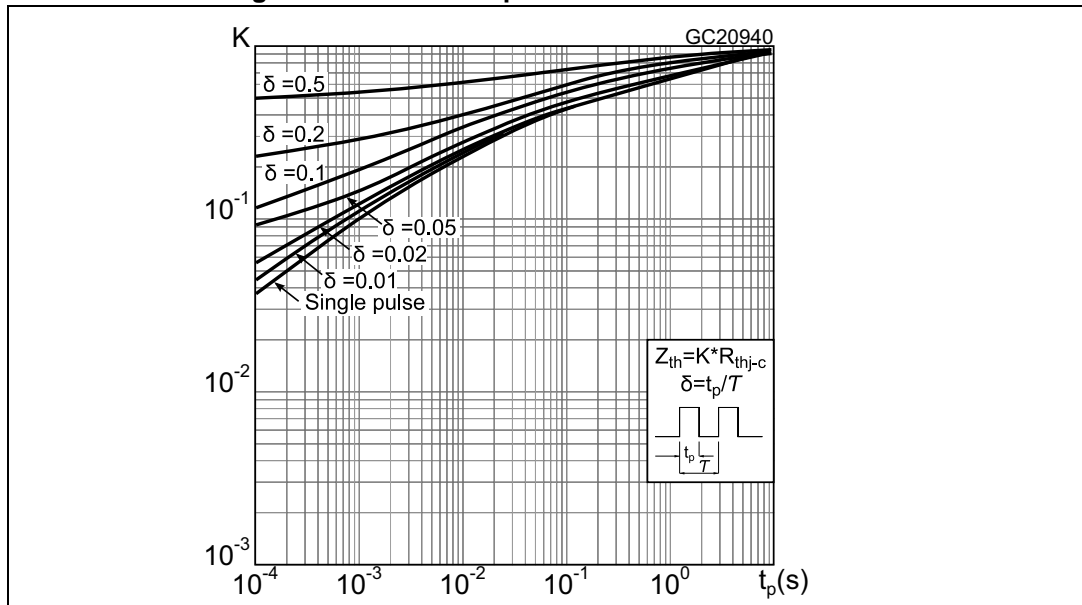

Figure 34. Thermal impedance for TO-220FP diode



### 3 Test circuits

Figure 35. Test circuit for inductive load switching

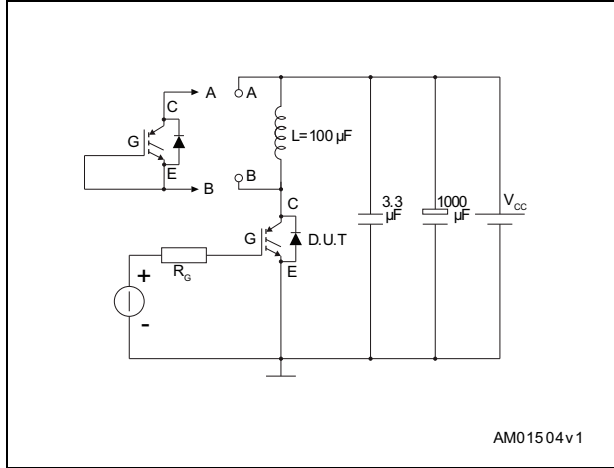

Figure 36. Gate charge test circuit

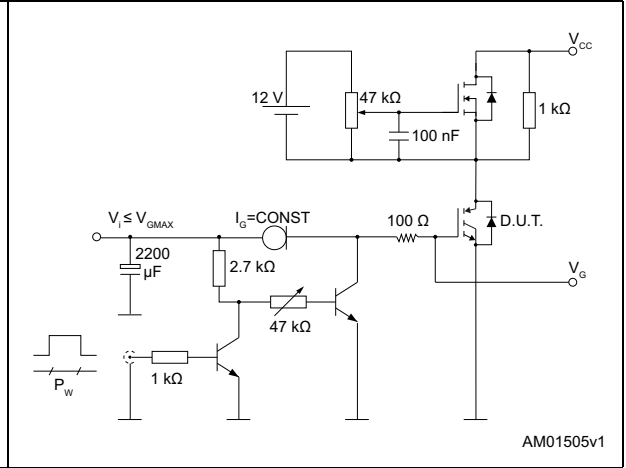

Figure 37. Switching waveform

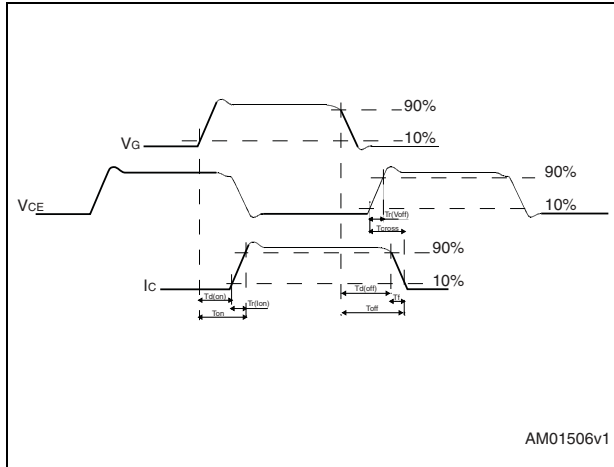
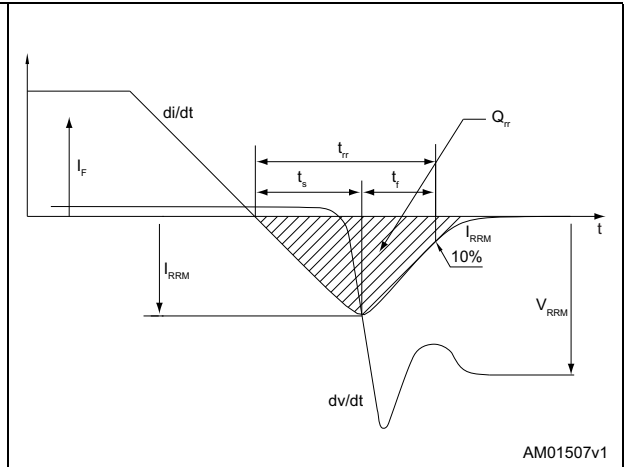

Figure 38. Diode reverse recovery waveform



## 4 Package information

In order to meet environmental requirements, ST offers these devices in different grades of ECOPACK<sup>®</sup> packages, depending on their level of environmental compliance. ECOPACK<sup>®</sup> specifications, grade definitions and product status are available at: [www.st.com](http://www.st.com). ECOPACK is an ST trademark.

### 4.1 D<sup>2</sup>PAK package information

Figure 39. D<sup>2</sup>PAK (TO-263) type A package outline

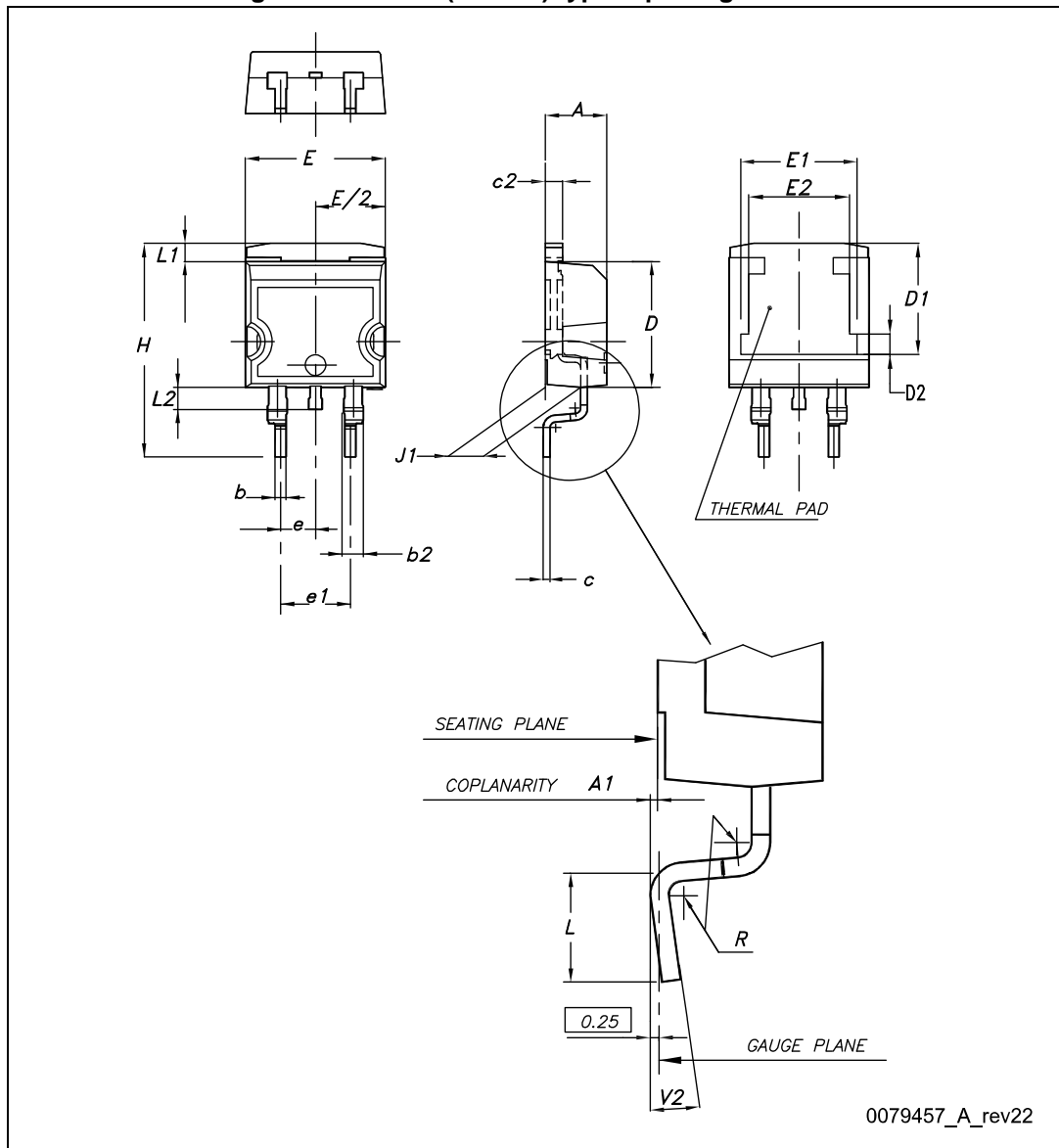
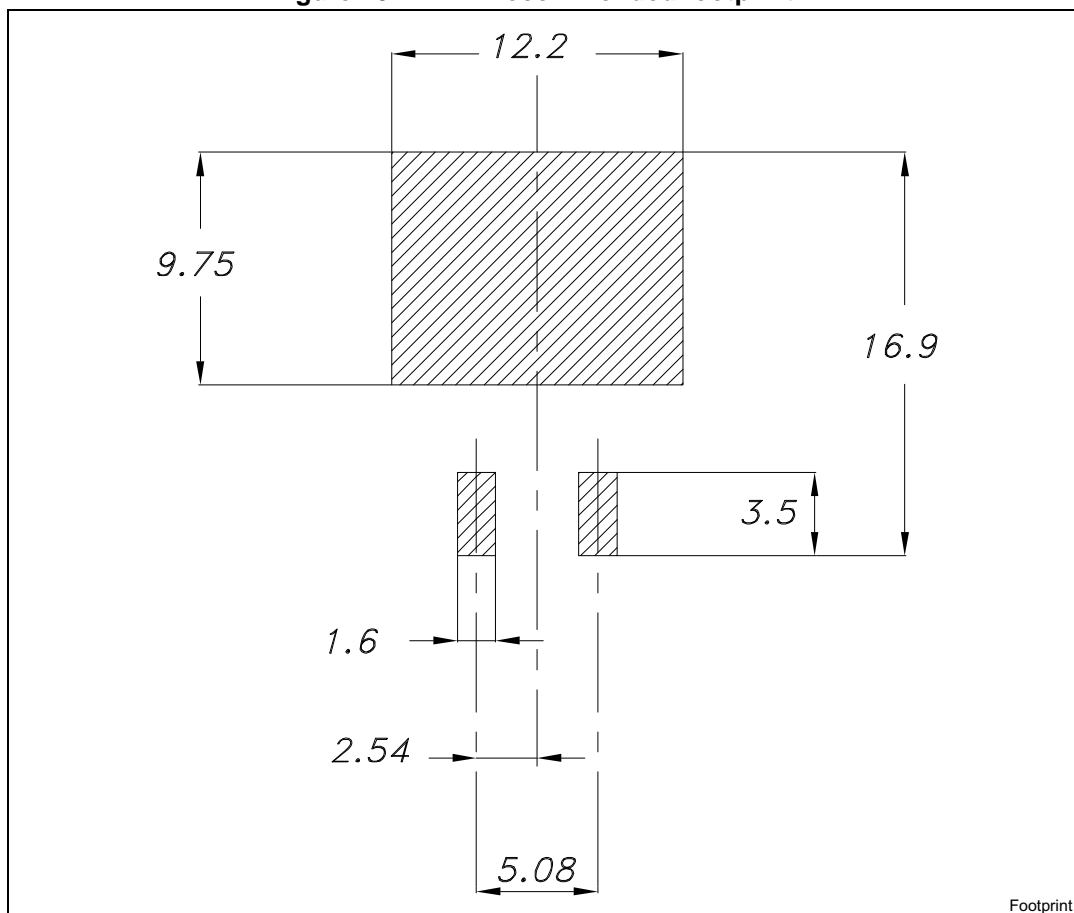

Table 9. D<sup>2</sup>PAK (TO-263) type A mechanical data

Dim.	mm		
	Min.	Typ.	Max.
A	4.40		4.60
A1	0.03		0.23
b	0.70		0.93
b2	1.14		1.70
c	0.45		0.60
c2	1.23		1.36
D	8.95		9.35
D1	7.50	7.75	8.00
D2	1.10	1.30	1.50
E	10		10.40
E1	8.50	8.70	8.90
E2	6.85	7.05	7.25
e		2.54	
e1	4.88		5.28
H	15		15.85
J1	2.49		2.69
L	2.29		2.79
L1	1.27		1.40
L2	1.30		1.75
R		0.4	
V2	0°		8°



Figure 40. D<sup>2</sup>PAK recommended footprint<sup>(a)</sup>



a. All dimension are in millimeters

## 4.2 D<sup>2</sup>PAK packing information

Figure 41. D<sup>2</sup>PAK tape outline

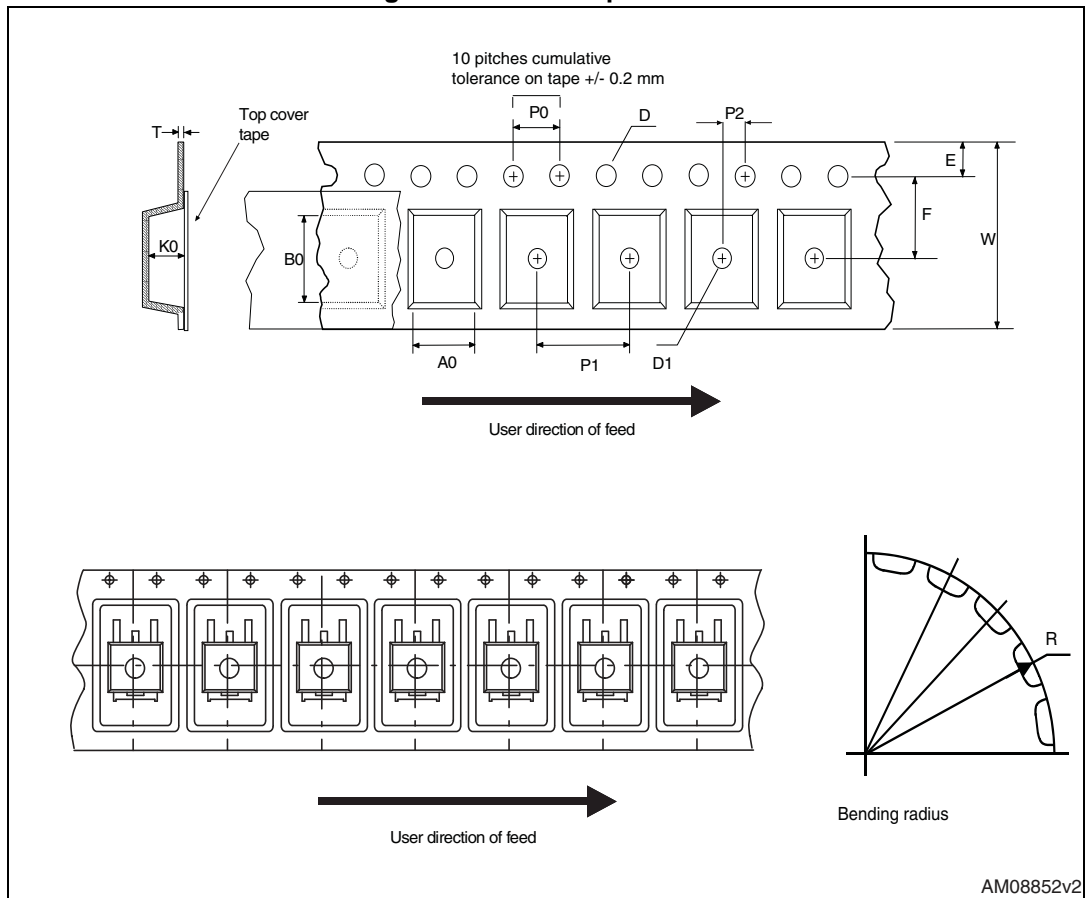

Figure 42. D<sup>2</sup>PAK reel outline

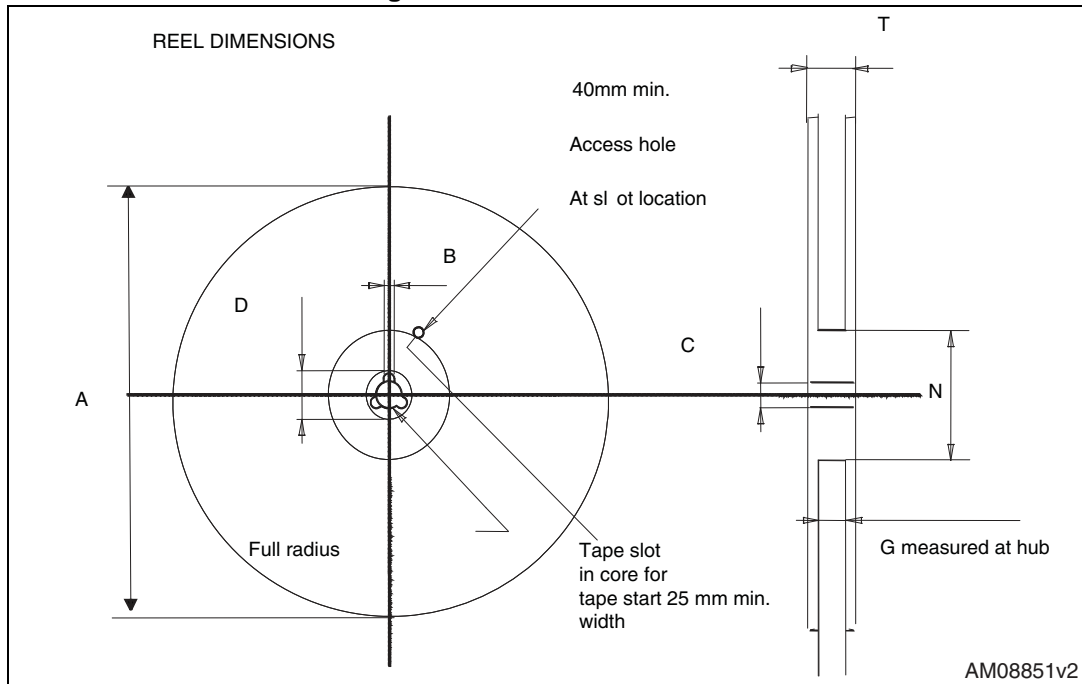
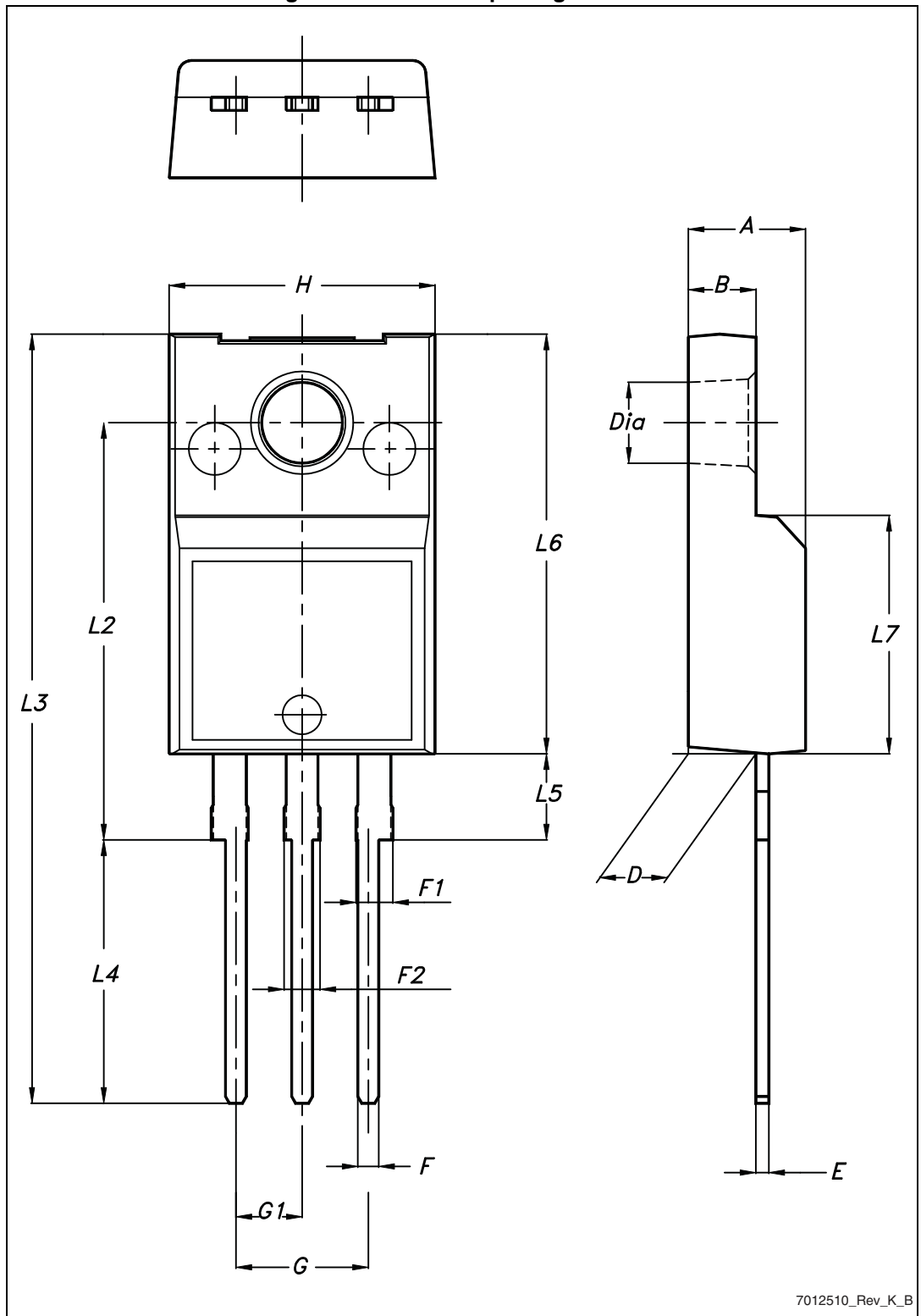

Table 10. D<sup>2</sup>PAK tape and reel mechanical data

Tape			Reel		
Dim.	mm		Dim.	mm	
	Min.	Max.		Min.	Max.
A0	10.5	10.7	A		330
B0	15.7	15.9	B	1.5	
D	1.5	1.6	C	12.8	13.2
D1	1.59	1.61	D	20.2	
E	1.65	1.85	G	24.4	26.4
F	11.4	11.6	N	100	
K0	4.8	5.0	T		30.4
P0	3.9	4.1			
P1	11.9	12.1	Base qty		1000
P2	1.9	2.1	Bulk qty		1000
R	50				
T	0.25	0.35			
W	23.7	24.3			

### 4.3 TO-220FP package information

Figure 43. TO-220FP package outline



7012510\_Rev\_K\_B

Table 11. TO-220FP package mechanical data

Dim.	mm		
	Min.	Typ.	Max.
A	4.4		4.6
B	2.5		2.7
D	2.5		2.75
E	0.45		0.7
F	0.75		1
F1	1.15		1.70
F2	1.15		1.70
G	4.95		5.2
G1	2.4		2.7
H	10		10.4
L2		16	
L3	28.6		30.6
L4	9.8		10.6
L5	2.9		3.6
L6	15.9		16.4
L7	9		9.3
Dia	3		3.2

### 4.4 TO-220 package information

Figure 44. TO-220 type A package outline

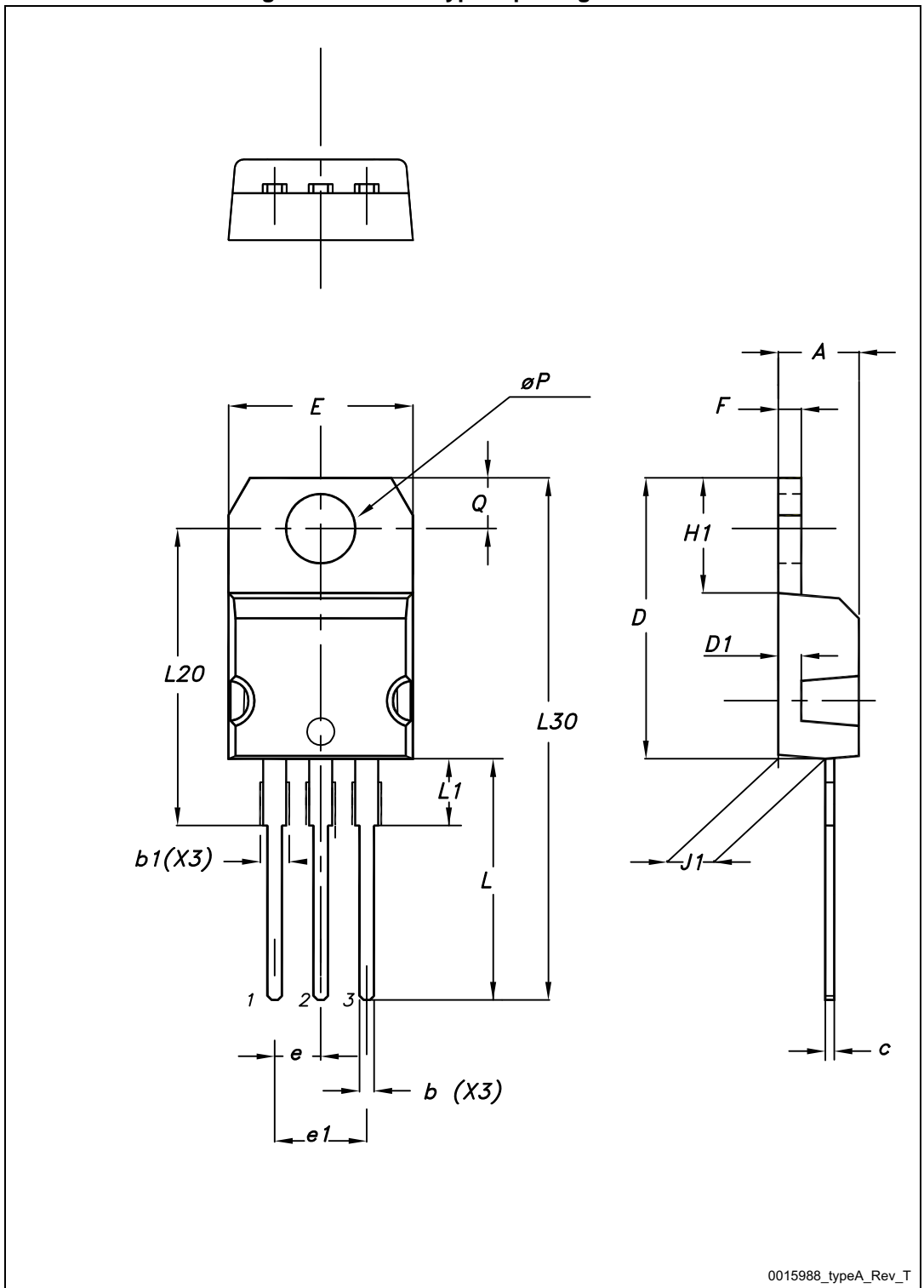

0015988\_typeA\_Rev\_T

Table 12. TO-220 type A package mechanical data

Dim.	mm		
	Min.	Typ.	Max.
A	4.40		4.60
b	0.61		0.88
b1	1.14		1.70
c	0.48		0.70
D	15.25		15.75
D1		1.27	
E	10		10.40
e	2.40		2.70
e1	4.95		5.15
F	1.23		1.32
H1	6.20		6.60
J1	2.40		2.72
L	13		14
L1	3.50		3.93
L20		16.40	
L30		28.90	
ØP	3.75		3.85
Q	2.65		2.95

## 5 Revision history

Table 13. Document revision history

Date	Revision	Changes
24-Feb-2015	1	Initial release.
05-Jun-2015	2	Text and formatting changes throughout document In <a href="#">Section 1: Electrical ratings</a> - updated <a href="#">Table 3</a> In <a href="#">Section 2: Electrical characteristics</a> - updated <a href="#">Table 4</a> , <a href="#">Table 5</a> , <a href="#">Table 6</a> , <a href="#">Table 7</a> and <a href="#">Table 8</a> - added <a href="#">Section 2.1: Electrical characteristics (curves)</a>



**IMPORTANT NOTICE – PLEASE READ CAREFULLY**

STMicroelectronics NV and its subsidiaries ("ST") reserve the right to make changes, corrections, enhancements, modifications, and improvements to ST products and/or to this document at any time without notice. Purchasers should obtain the latest relevant information on ST products before placing orders. ST products are sold pursuant to ST's terms and conditions of sale in place at the time of order acknowledgement.

Purchasers are solely responsible for the choice, selection, and use of ST products and ST assumes no liability for application assistance or the design of Purchasers' products.

No license, express or implied, to any intellectual property right is granted by ST herein.

Resale of ST products with provisions different from the information set forth herein shall void any warranty granted by ST for such product.

ST and the ST logo are trademarks of ST. All other product or service names are the property of their respective owners.

Information in this document supersedes and replaces information previously supplied in any prior versions of this document.

© 2015 STMicroelectronics – All rights reserved