

REFERENCE SPECIFICATIONS

-NFC 93425 (in compliance with HE 507)

PHYSICAL CHARACTERISTICS

- INSULATOR MATERIAL: THERMOPLASTIC UL94V0
- CONTACT MATERIAL: PHOSPHOR BRONZE(SIGNAL CONTACT)
BRASS (POWERS CONTACT)
- ACCESSORIES: BRASS
- SHELLS: STEEL

ELECTRICAL CHARACTERISTICS

- NOMINAL CURRENT: 7.5A (SIGNAL CONTACT)
30A or 40A (POWER CONTACT)
- CONTACT RESISTANCE: <=7.3 m Ohms(SIGNAL and POWER)
- CONTACT/CONTACT : >=1000 V
- CONTACT/GROUND : >=1200 V
- INSULATION RESISTANCE: >=5000 MOhms

ENVIRONMENTAL CHARACTERISTICS

- CLIMATIC CATEGORY: 55/125/21
TEMPERATURE RANGE -55°C TO +125°C
DAMP HEAT STEADY STATE 21 DAYS
SALT SPRAY 24 HOURS

MECHANICAL CHARACTERISTICS

- RETENTION AGAINST TORQUE: - Threaded insert: 0.7 N.m Maximum
- Female screw : 0.5 N.m Maximum

NOTE RoHS INFORMATION

- The "LF" products meet european union Directives and other country regulations as described in GS-47-0004.
- The housing will withstand exposure to 260°C peak temperature for 3.5 seconds in a wave solder application with a 1.6mm minimum thick circuit board. See application notes/procedures if they are available.
- Termination plating spec:
 - Signal contacts: Ni + Gold/GxT
 - Power contacts: Ni 1.27µmi+Sn 2.5 to 7.5µ,pure bright
- Active area plating spec:
 - Signal and power contacts: Ni + Gold/GxT
- Shell plating :2 to 4µm Cu + nickel + 3 to 10µmm Sn,pure bright
- Accessories: Sn pure bright + nickel
- Packaging spec: See GS-14-920

DBL13W3S500G30LF

Series

Shell size: **E A B C D**
(see sheet 3)

Front accessory definition
(see sheet 2)

- blank**: without accessory
- L** : threaded insert M3
- O** : threaded insert UNC 4-40
- V** : female screw UNC 4-40

Layout of contacts (see sheet 3)

Contacts
S : Socket

Termination type
5 Right angle/Europe standard

Plating
00 200 matings/unmatings
43 500 matings/unmatings

PCB accessories definition(see sheet 2)
A : without accessory
H : Metal brackets+harpoons for PCB 2.40mm
G : Metal brackets+harpoons for PCB 1.60mm
M : Metal brackets

Power contacts
00 : No fitted with power contact (Signal contact always fitted)
30 : Fitted with power contacts 30 Amp.
40 : Fitted with power contacts 40 Amp.

See note RoHS

TABLE 1: PCB HOLE DIAMETERS

	POWER CONTACTS		ACCESSORIES	SIGNAL CONTACT
30 A	2.00	∅2.40	∅3.10	∅1.00
40 A	2.80	∅3.10		
Max current power	∅A±0.1	PCB HOLE ±0.1	PCB HOLE ±0.1	PCB HOLE

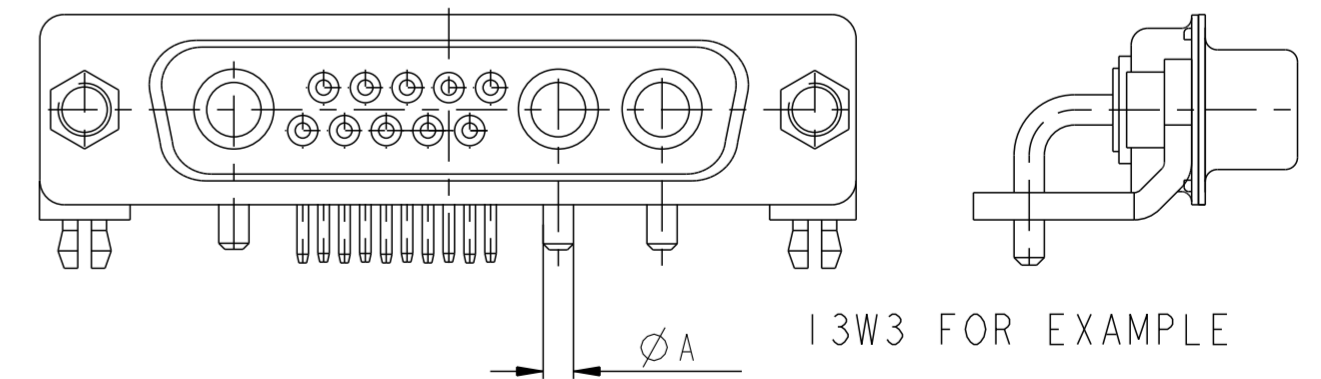

spec ref	dr	GREGAR M	2019-01-07	projection	MM	size	A2	scale	1:1
tolerance std	eng	MITHUN PAUL	2019-01-07			ecn no	ELX+32326	rel level	rev
ISO 406	chr	-	-						
ISO 1101	appr	BIJU K PAUL	2019-01-07						
surface	linear			SUB FEMALE DMW EUROPE		cat. no.	C01-8639-2300	sheet 1 of 7	F
ISO 1302	angular			mixed power right angled solder					

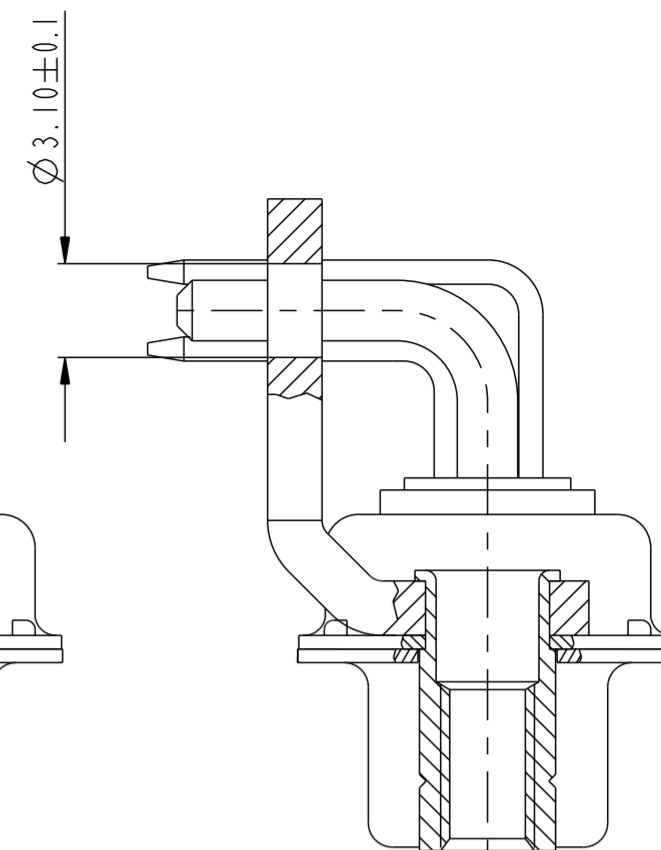
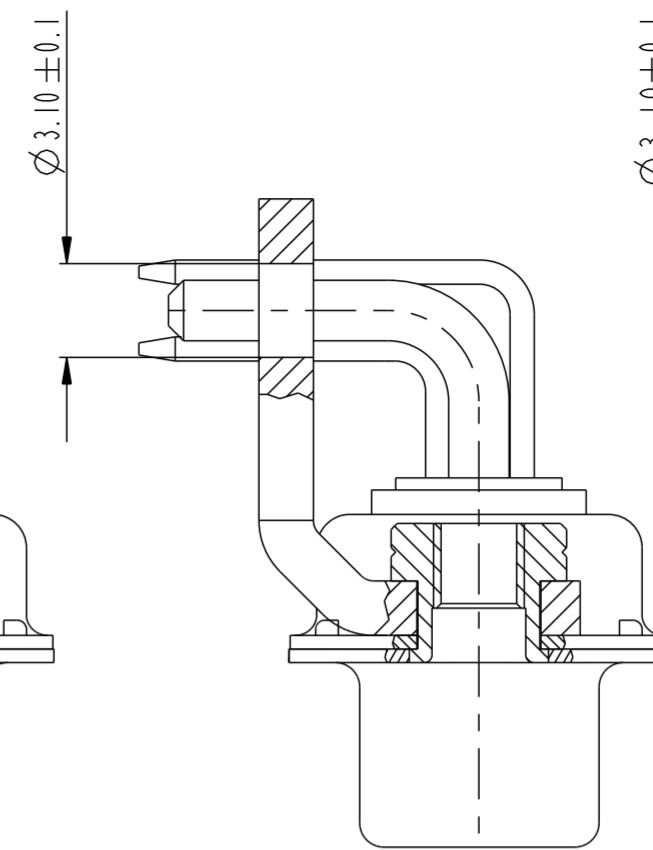
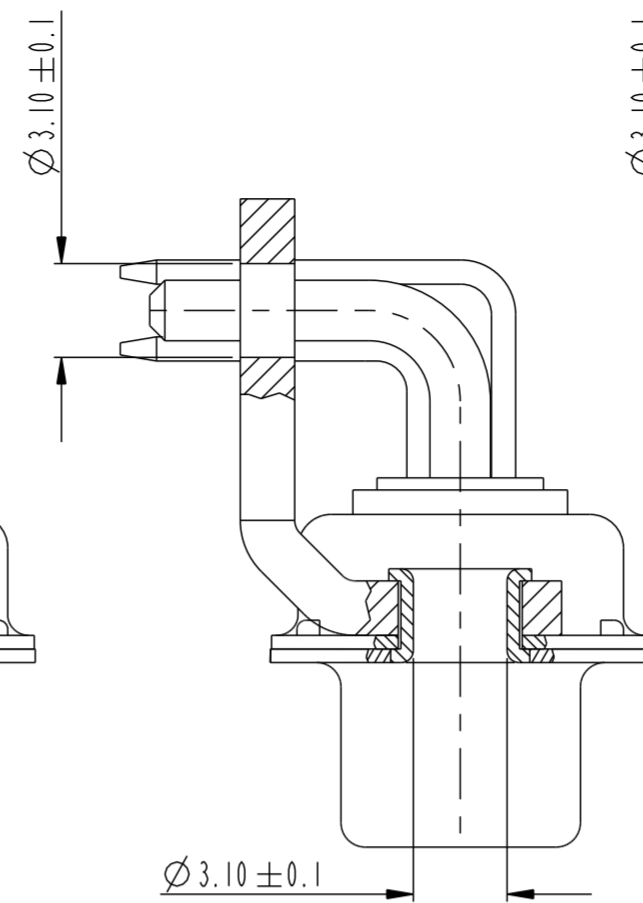
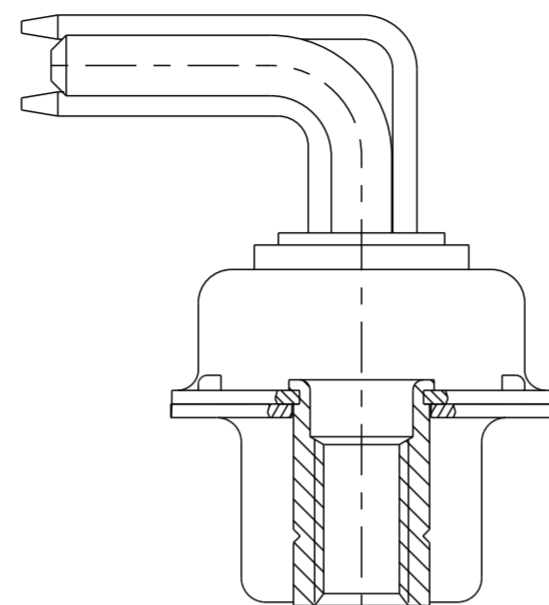
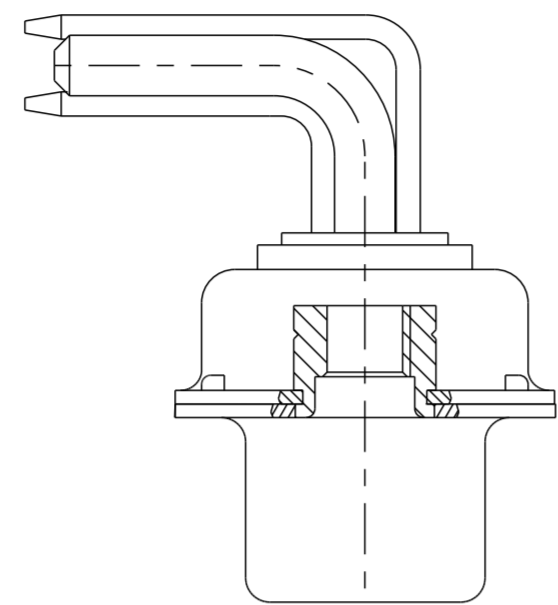
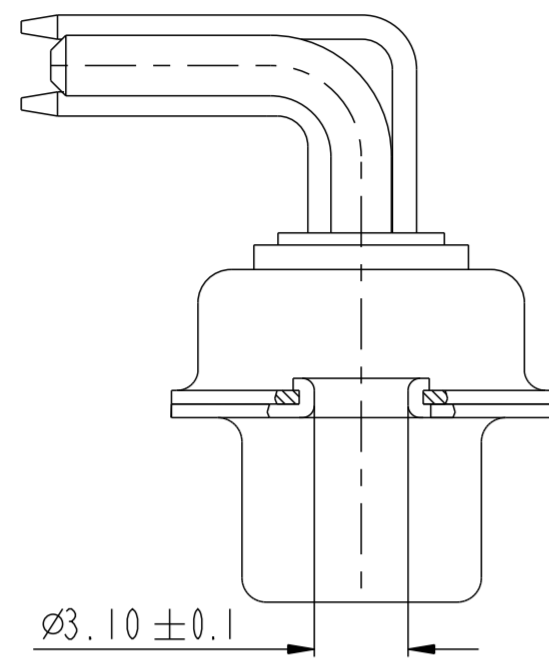

FRONT ACCESSORY	Blank Without	L insert M3 O insert UNC 4.40	V insert UNC 4.40	Blank Without	L insert M3 O insert UNC 4.40	V insert UNC 4.40
PCB ACCESSORIES	A Without	A Without	A Without	M Metal brackets	M Metal brackets	M Metal bracket

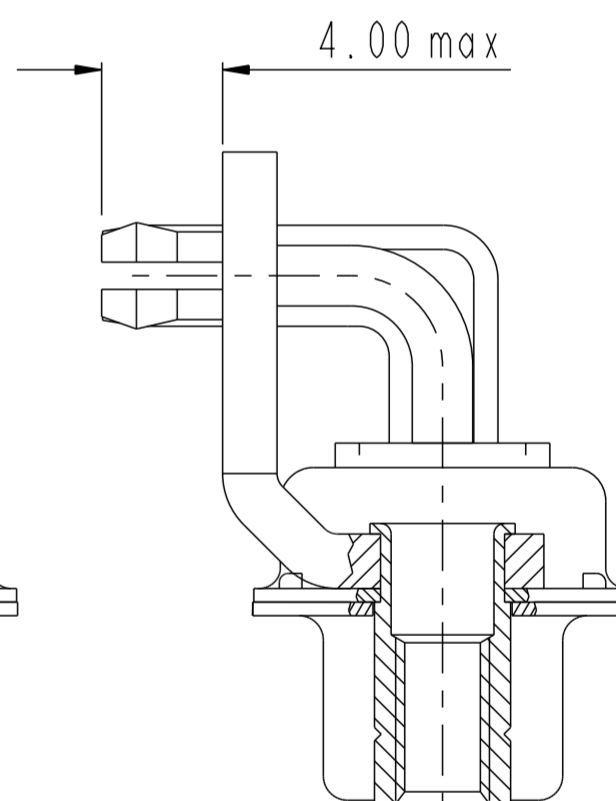
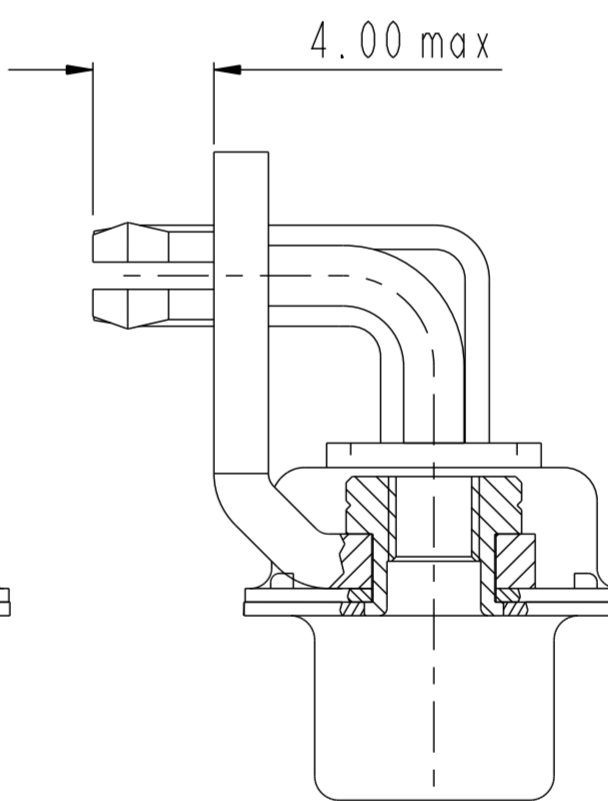
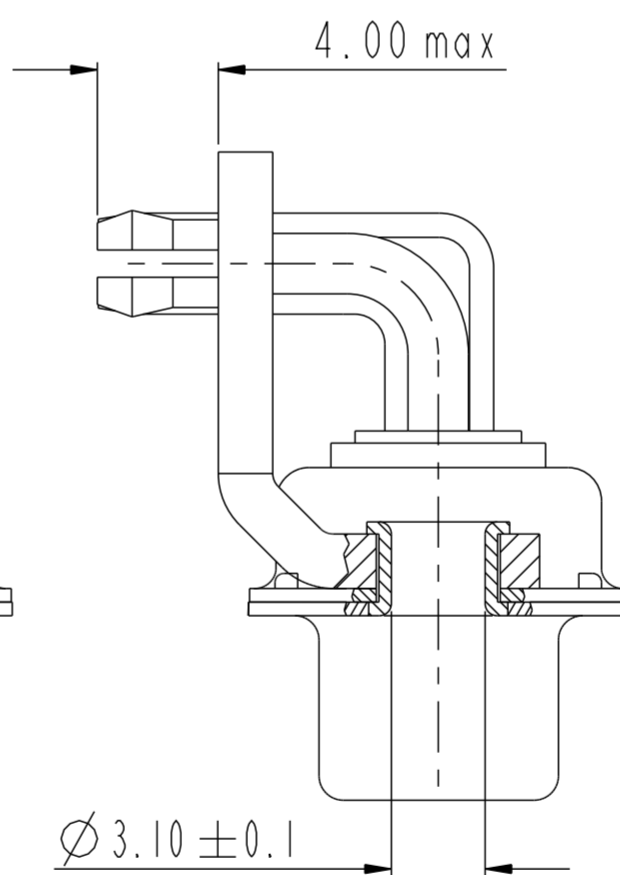
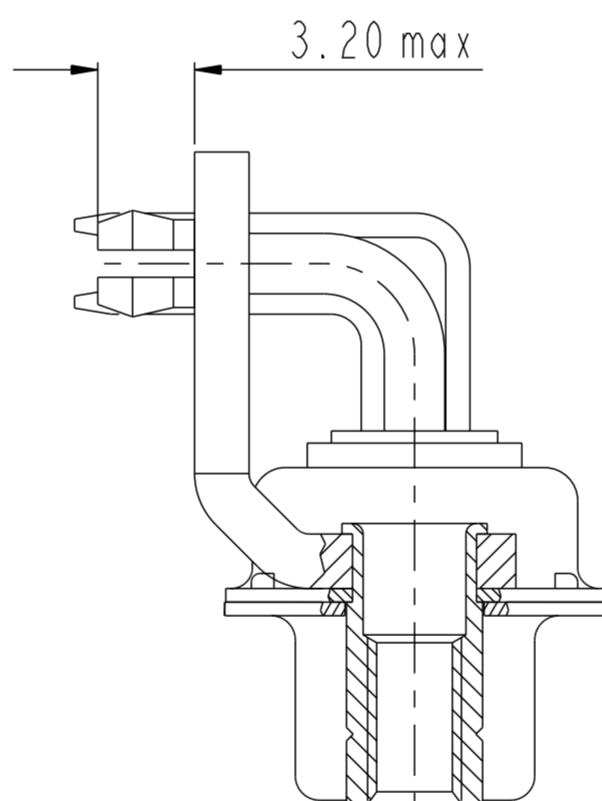
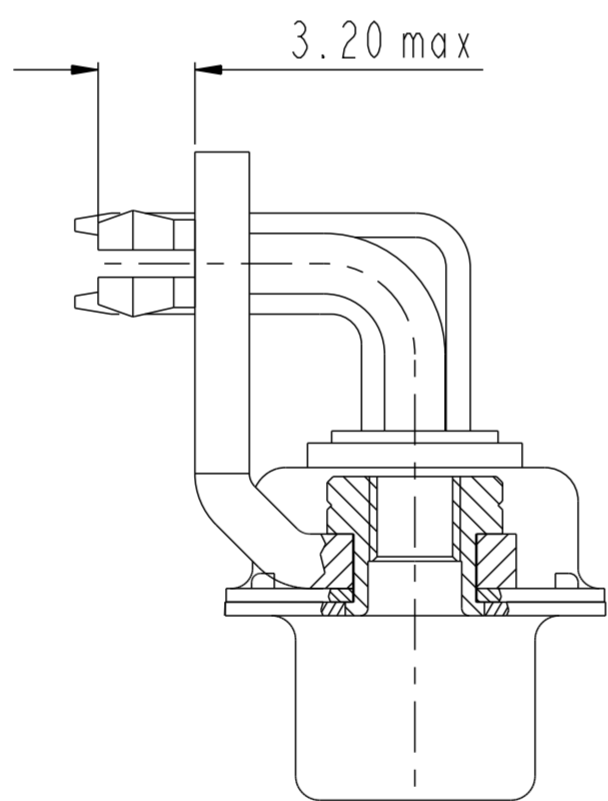
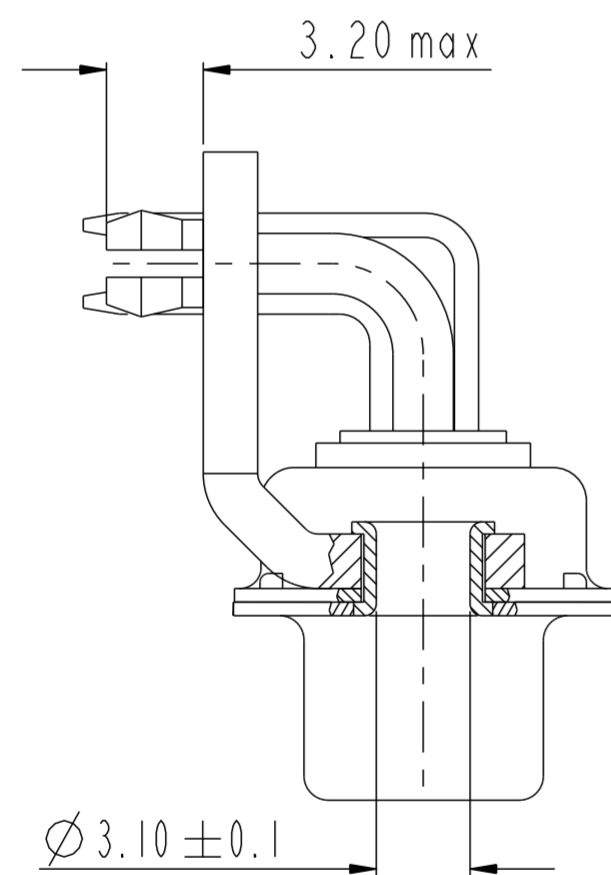

FRONT ACCESSORY	Blank Without	L insert M3 O insert UNC 4.40	V insert UNC 4.40	Blank Without	L insert M3 O insert UNC 4.40	V insert UNC 4.40
PCB ACCESSORIES	G Metal brackets + harpoons for PCB 1.60mm	G Metal brackets + harpoons for PCB 1.60mm	G Metal brackets + harpoons for PCB 1.60mm	H Metal brackets + harpoons for PCB 2.40mm	H Metal brackets + harpoons for PCB 2.40mm	H Metal brackets + harpoons for PCB 2.40mm

SCALE: 4

dr	GREGAR M	2019-01-07	projection	MM	size	A2	scale	1:1
eng	MITHUN PAUL	2019-01-07			ecn no	ELX+32326	rel level	rev
chr	-	-						
appr	BIJU K PAUL	2019-01-07	product family	-	rel level	-	cat. no.	-
Amphenol FCI			SUB FEMALE DMW EUROPE mixed power right angled solder			C01-8639-2300	sheet 2 of 7	F

PART NUMBER	AMPS	MATINGS/ UNMATINGS	FRONT ACCESSORY	PCB ACCESSORIES
D*xWxS500A30LF	30	200	without	without
D*LxWxS500A30LF	30	200	insert M3	without
D*OxWxS500A30LF	30	200	insert UNC 4.40	without
D*VxWxS500A30LF	30	200	female screw UNC 4.40	without
D*xWxS500H30LF	30	200	without	metal bracket+harpoon PCB 2.40mm
D*LxWxS500H30LF	30	200	insert M3	metal bracket+harpoon PCB 2.40mm
D*OxWxS500H30LF	30	200	insert UNC 4.40	metal bracket+harpoon PCB 2.40mm
D*VxWxS500H30LF	30	200	female screw UNC 4.40	metal bracket+harpoon PCB 2.40mm
D*xWxS500G30LF	30	200	without	metal bracket+harpoon PCB 1.60mm
D*LxWxS500G30LF	30	200	insert M3	metal bracket+harpoon PCB 1.60mm
D*OxWxS500G30LF	30	200	insert UNC 4.40	metal bracket+harpoon PCB 1.60mm
D*VxWxS500G30LF	30	200	female screw UNC 4.40	metal bracket+harpoon PCB 1.60mm
D*xWxS500M30LF	30	200	without	metal bracket
D*LxWxS500M30LF	30	200	insert M3	metal bracket
D*OxWxS500M30LF	30	200	insert UNC 4.40	metal bracket
D*VxWxS500M30LF	30	200	female screw UNC 4.40	metal bracket

PART NUMBER	AMPS	MATINGS/ UNMATINGS	FRONT ACCESSORY	PCB ACCESSORIES
D*xWxS500A40LF	40	200	without	without
D*LxWxS500A40LF	40	200	insert M3	without
D*OxWxS500A40LF	40	200	insert UNC 4.40	without
D*VxWxS500A40LF	40	200	female screw UNC 4.40	without
D*xWxS500H40LF	40	200	without	metal bracket+harpoon PCB 2.40mm
D*LxWxS500H40LF	40	200	insert M3	metal bracket+harpoon PCB 2.40mm
D*OxWxS500H40LF	40	200	insert UNC 4.40	metal bracket+harpoon PCB 2.40mm
D*VxWxS500H40LF	40	200	female screw UNC 4.40	metal bracket+harpoon PCB 2.40mm
D*xWxS500G40LF	40	200	without	metal bracket+harpoon PCB 1.60mm
D*LxWxS500G40LF	40	200	insert M3	metal bracket+harpoon PCB 1.60mm
D*OxWxS500G40LF	40	200	insert UNC 4.40	metal bracket+harpoon PCB 1.60mm
D*VxWxS500G40LF	40	200	female screw UNC 4.40	metal bracket+harpoon PCB 1.60mm
D*xWxS500M40LF	40	200	without	metal bracket
D*LxWxS500M40LF	40	200	insert M3	metal bracket
D*OxWxS500M40LF	40	200	insert UNC 4.40	metal bracket
D*VxWxS500M40LF	40	200	female screw UNC 4.40	metal bracket

shell size *
 E 5W1
 A 11W1
 A 7W2
 B 21W1
 B 17W2
 B 13W3
 B 9W4
 C 25W3
 C 21WA4
 C 27W2
 D 24W7

PART NUMBER	AMPS	MATINGS/ UNMATINGS	FRONT ACCESSORY	PCB ACCESSORIES
D*xWxS543A30LF	30	500	without	without
D*LxWxS543A30LF	30	500	insert M3	without
D*OxWxS543A30LF	30	500	insert UNC 4.40	without
D*VxWxS543A30LF	30	500	female screw UNC 4.40	without
D*xWxS543H30LF	30	500	without	metal bracket+harpoon PCB 2.40mm
D*LxWxS543H30LF	30	500	insert M3	metal bracket+harpoon PCB 2.40mm
D*OxWxS543H30LF	30	500	insert UNC 4.40	metal bracket+harpoon PCB 2.40mm
D*VxWxS543H30LF	30	500	female screw UNC 4.40	metal bracket+harpoon PCB 2.40mm
D*xWxS543G30LF	30	500	without	metal bracket+harpoon PCB 1.60mm
D*LxWxS543G30LF	30	500	insert M3	metal bracket+harpoon PCB 1.60mm
D*OxWxS543G30LF	30	500	insert UNC 4.40	metal bracket+harpoon PCB 1.60mm
D*VxWxS543G30LF	30	500	female screw UNC 4.40	metal bracket+harpoon PCB 1.60mm
D*xWxS543M30LF	30	500	without	metal bracket
D*LxWxS543M30LF	30	500	insert M3	metal bracket
D*OxWxS543M30LF	30	500	insert UNC 4.40	metal bracket
D*VxWxS543M30LF	30	500	female screw UNC 4.40	metal bracket

PART NUMBER	AMPS	MATINGS/ UNMATINGS	FRONT ACCESSORY	PCB ACCESSORIES
D*xWxS543A40LF	40	500	without	without
D*LxWxS543A40LF	40	500	insert M3	without
D*OxWxS543A40LF	40	500	insert UNC 4.40	without
D*VxWxS543A40LF	40	500	female screw UNC 4.40	without
D*xWxS543H40LF	40	500	without	metal bracket+harpoon PCB 2.40mm
D*LxWxS543H40LF	40	500	insert M3	metal bracket+harpoon PCB 2.40mm
D*OxWxS543H40LF	40	500	insert UNC 4.40	metal bracket+harpoon PCB 2.40mm
D*VxWxS543H40LF	40	500	female screw UNC 4.40	metal bracket+harpoon PCB 2.40mm
D*xWxS543G40LF	40	500	without	metal bracket+harpoon PCB 1.60mm
D*LxWxS543G40LF	40	500	insert M3	metal bracket+harpoon PCB 1.60mm
D*OxWxS543G40LF	40	500	insert UNC 4.40	metal bracket+harpoon PCB 1.60mm
D*VxWxS543G40LF	40	500	female screw UNC 4.40	metal bracket+harpoon PCB 1.60mm
D*xWxS543M40LF	40	500	without	metal bracket
D*LxWxS543M40LF	40	500	insert M3	metal bracket
D*OxWxS543M40LF	40	500	insert UNC 4.40	metal bracket
D*VxWxS543M40LF	40	500	female screw UNC 4.40	metal bracket

dr	GREGAR M	2019-01-07	projection	MM	size	A2	scale	1:1
eng	MITHUN PAUL	2019-01-07		←→	ecn no	ELX+32326	rel level	rev
chr	-	-						
appr	BIJU K PAUL	2019-01-07	product family	-	C01-8639-2300		F	
Amphenol FCI			SUB FEMALE DMW EUROPE			mixed power right angled solder		cat. no.

5W1

LAYOUT AND CONNECTOR DIMENSIONS

For PCB hole diameters see table I sheet I

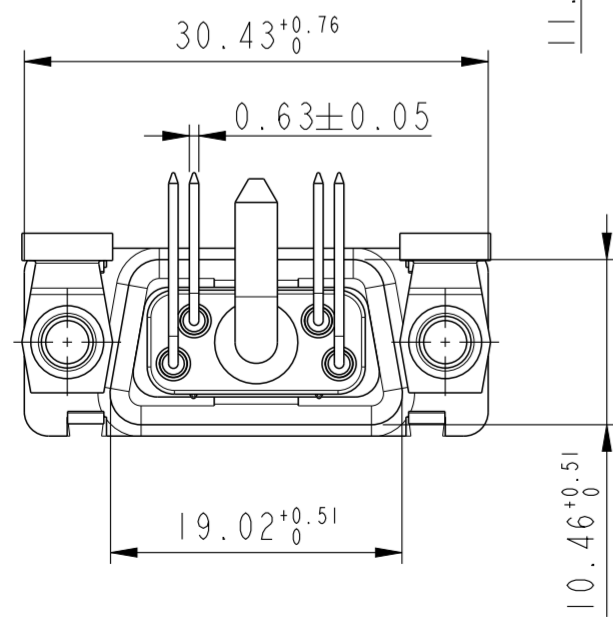
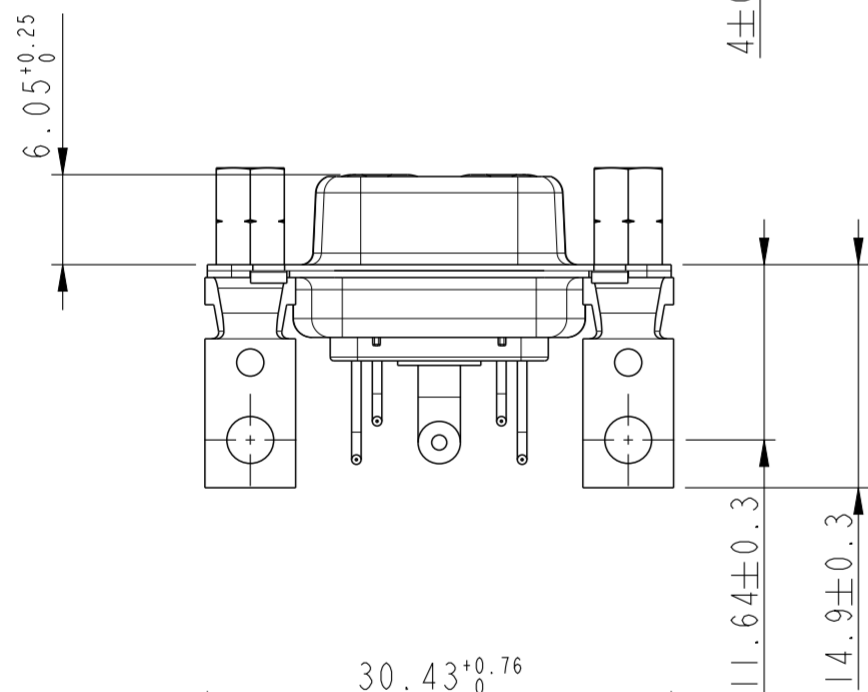
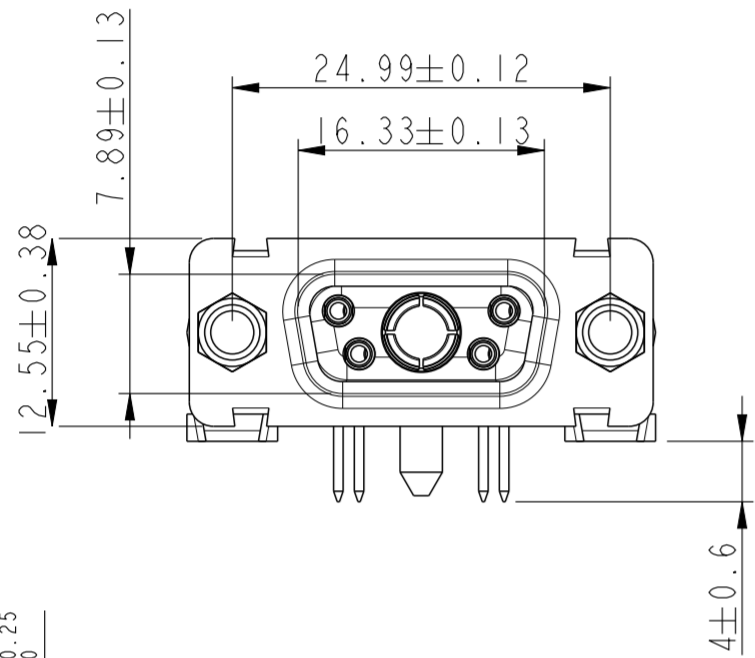
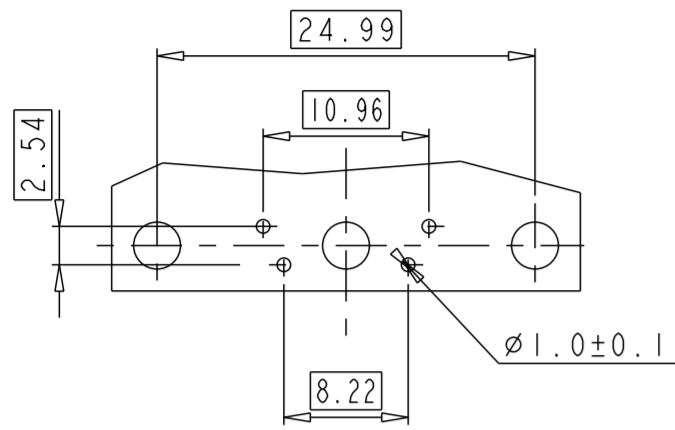

Floating signal contacts

11W1

LAYOUT AND CONNECTOR DIMENSIONS

For PCB hole diameters see table I sheet I

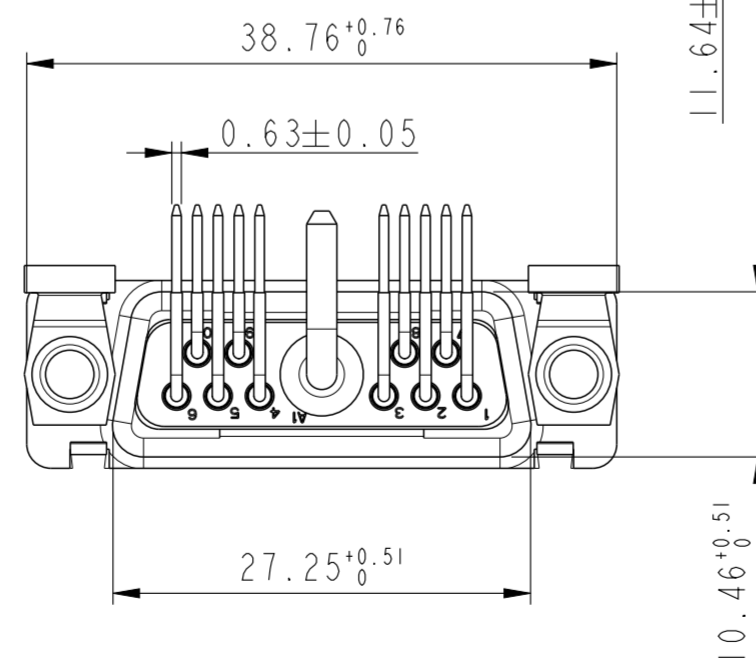
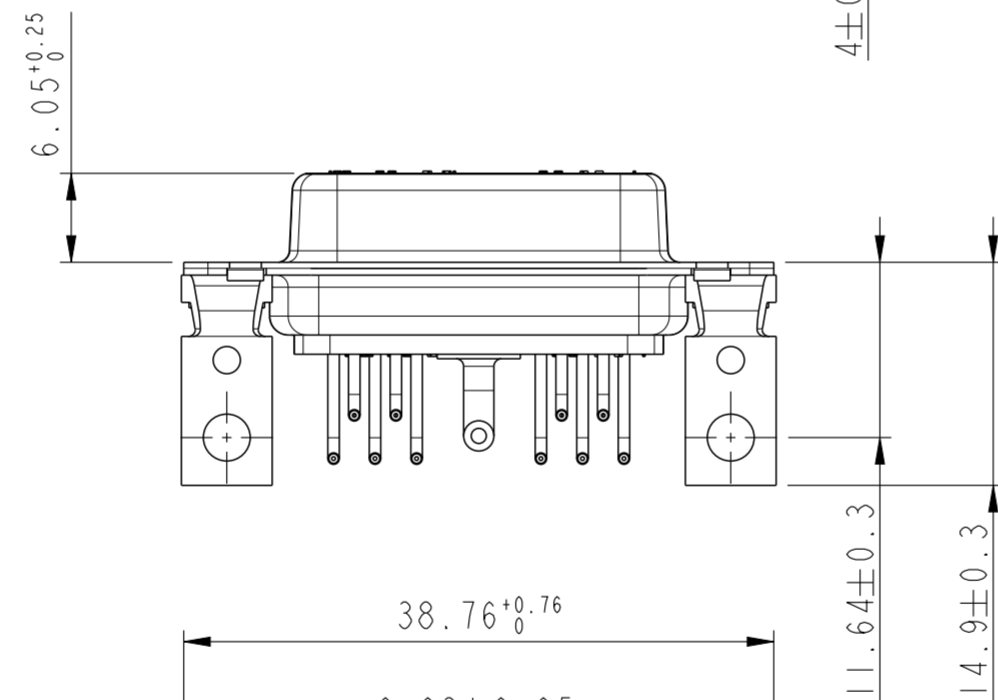
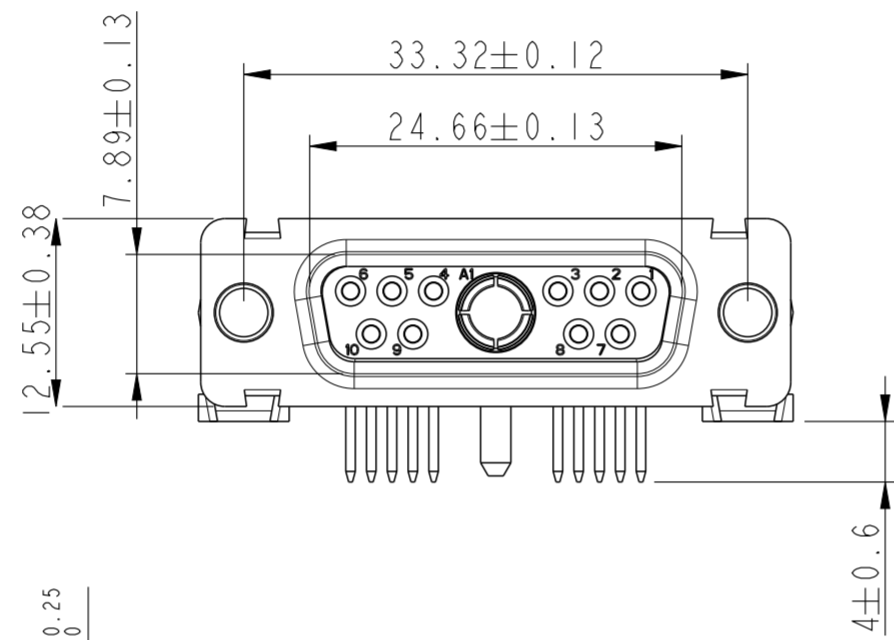
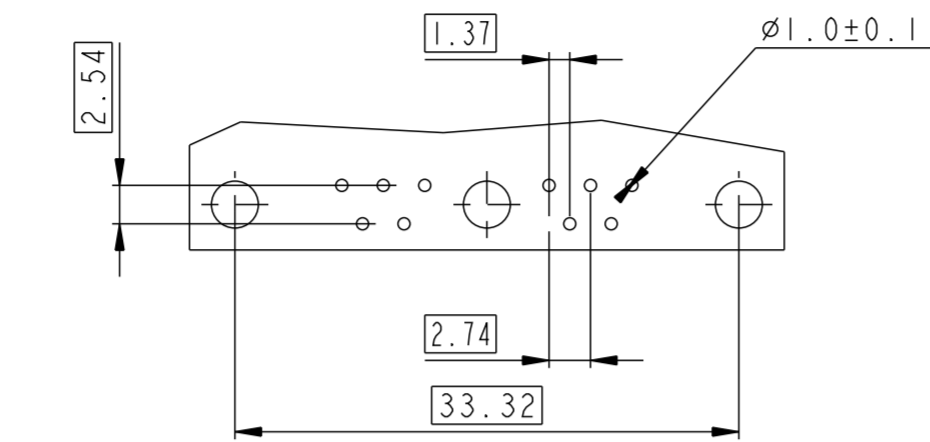

7W2

LAYOUT AND CONNECTOR DIMENSIONS

For PCB hole diameters see table I sheet I

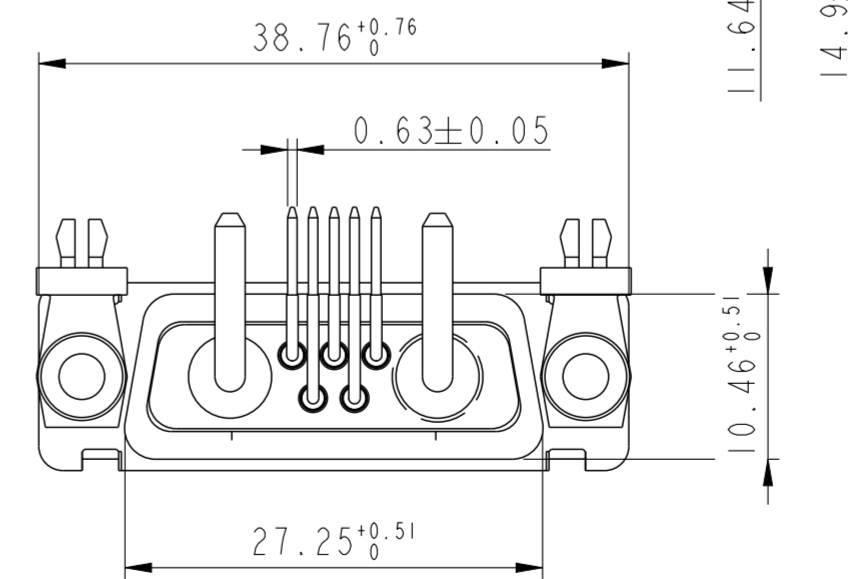
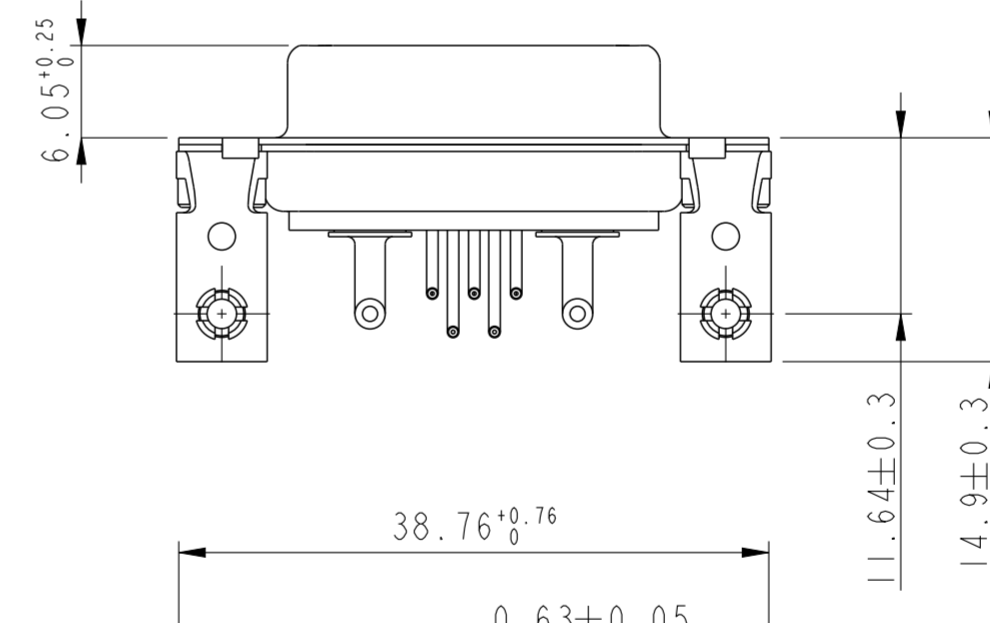
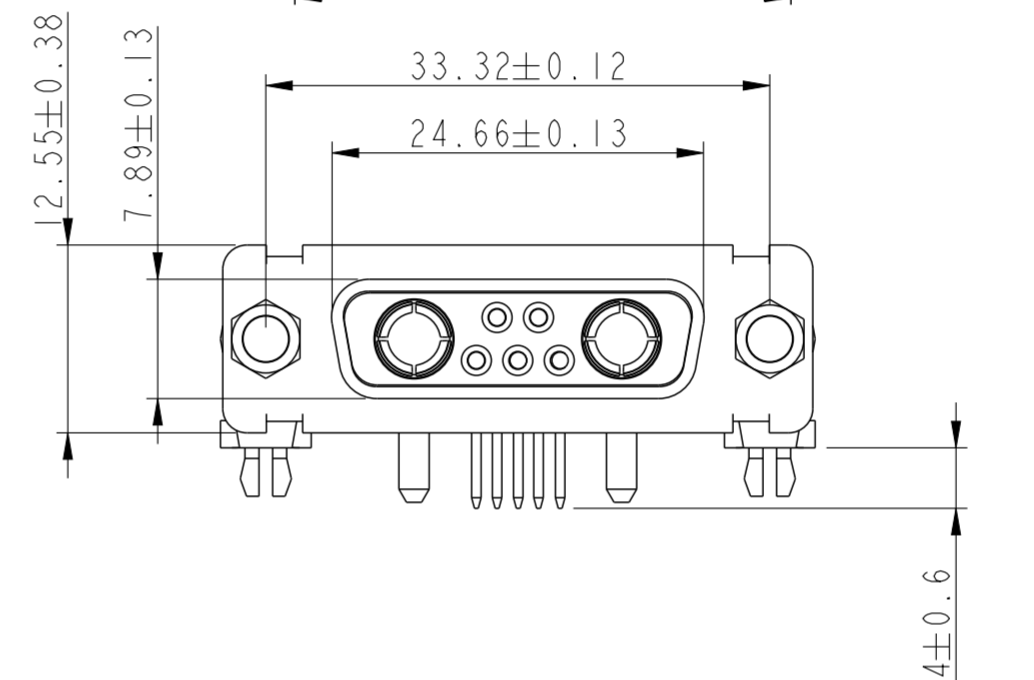
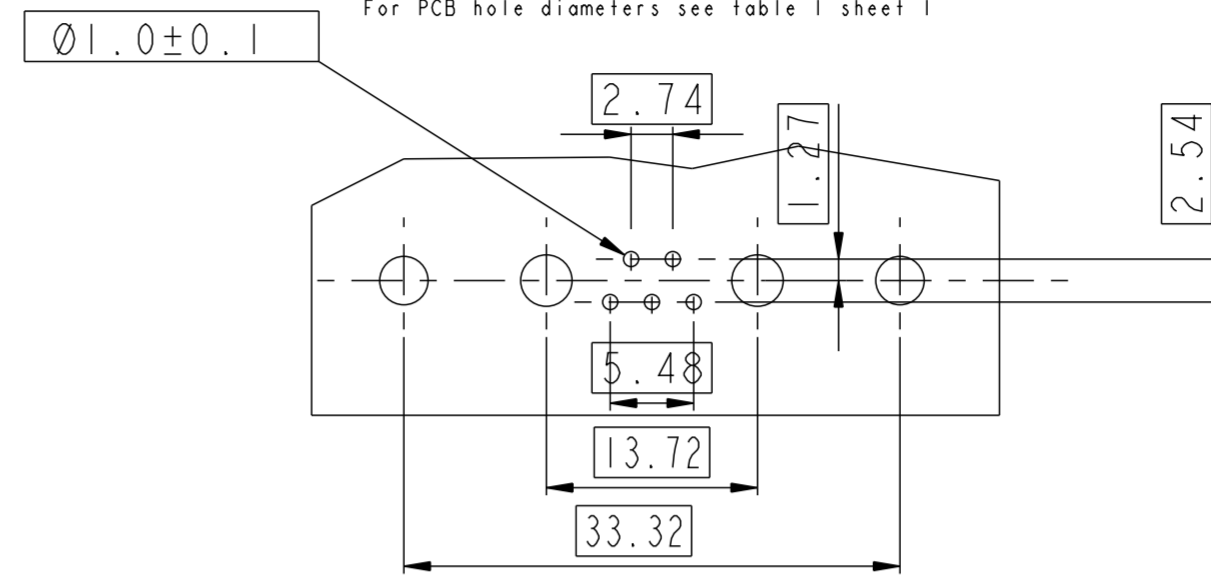

SIDE VIEW FOR ALL LAYOUTS EXCEPT SIZE "D"

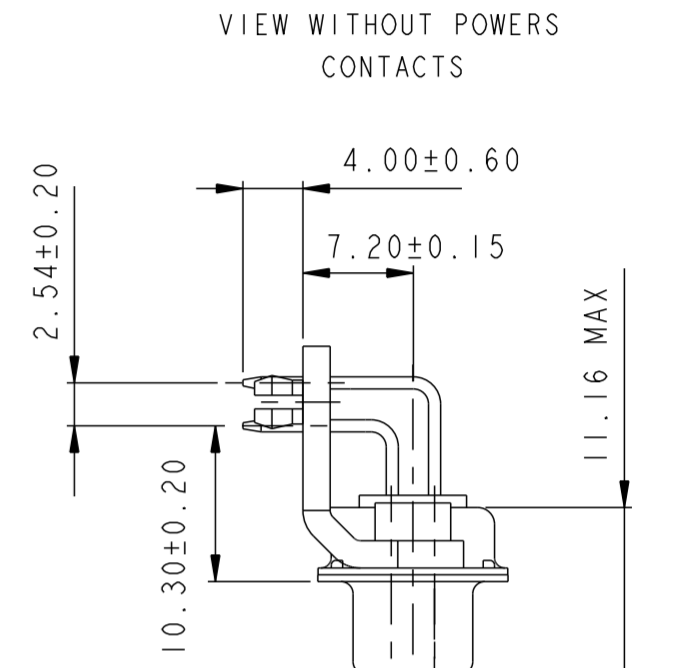

VIEW WITH POWERS CONTACTS

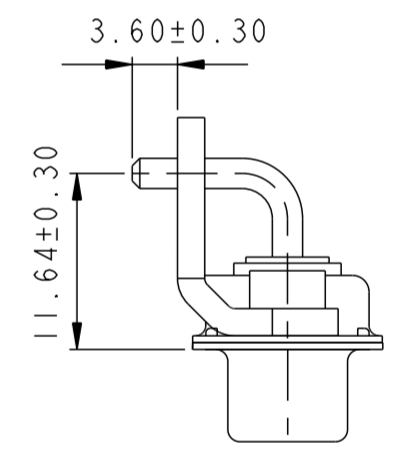

SIDE VIEW FOR LAYOUTS SHELL SIZE "D"

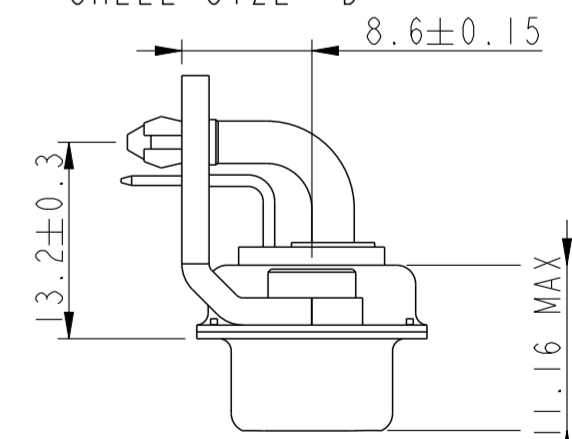

Amphenol FCI

© 2016 AFCI

dr	GREGAR M	2019-01-07	projection	MM	size	A2	scale	1:1
eng	MITHUN PAUL	2019-01-07			ecn no	ELX-32326	rel level	rev
chr	-	-						
appr	BIJU K PAUL	2019-01-07	product family	-	rel level	-	cat. no.	-
Amphenol FCI			SUB FEMALE DMW EUROPE mixed power right angled solder			dwg no C01-8639-2300	sheet 4 of 7	F

PDS: Rev :F

STATUS:Released

Printed: Jan 24, 2019

13W3

LAYOUT AND CONNECTOR DIMENSIONS
For PCB hole diameters see table I sheet I

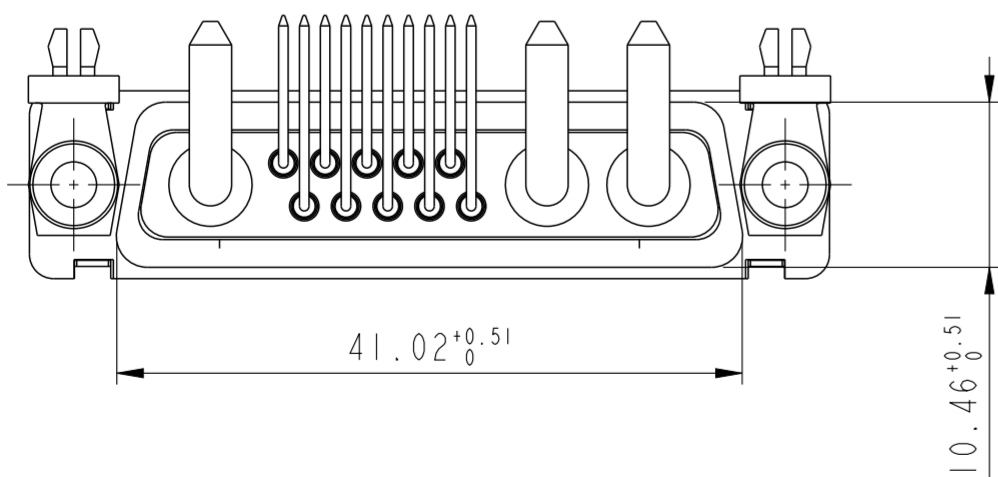
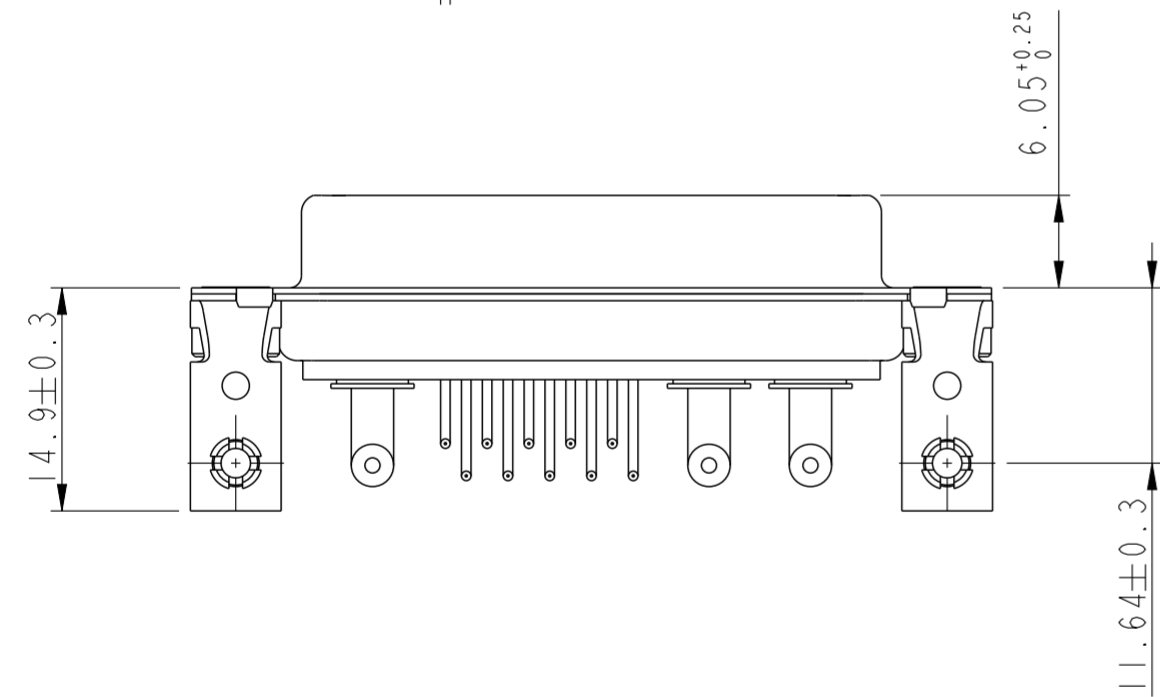
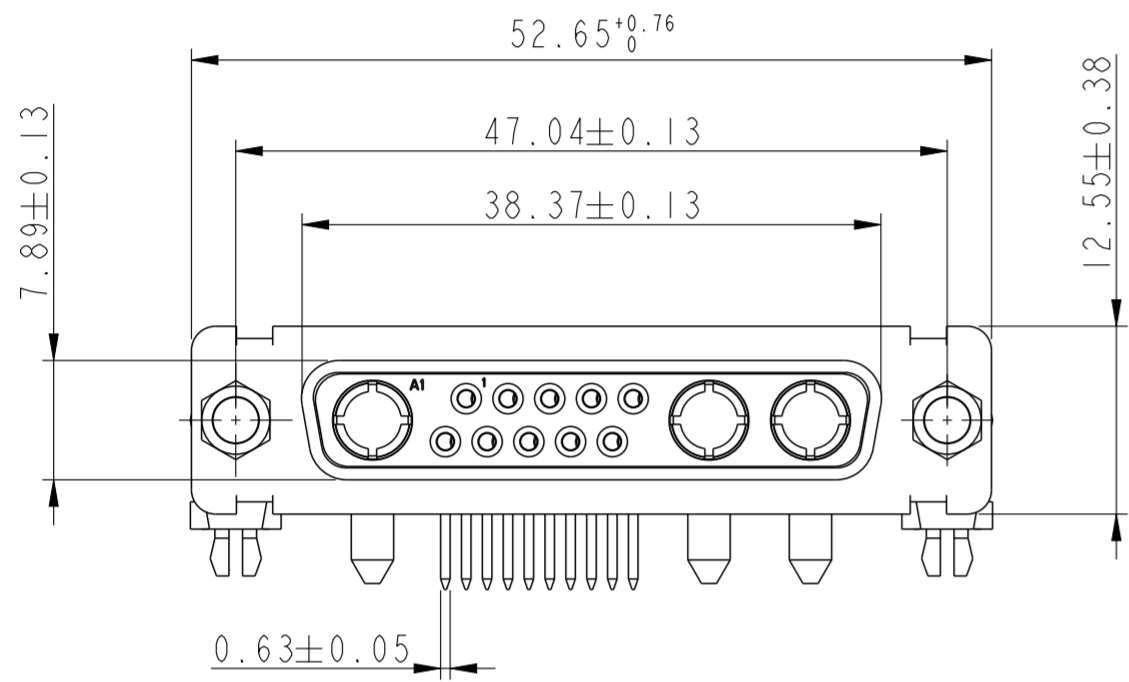
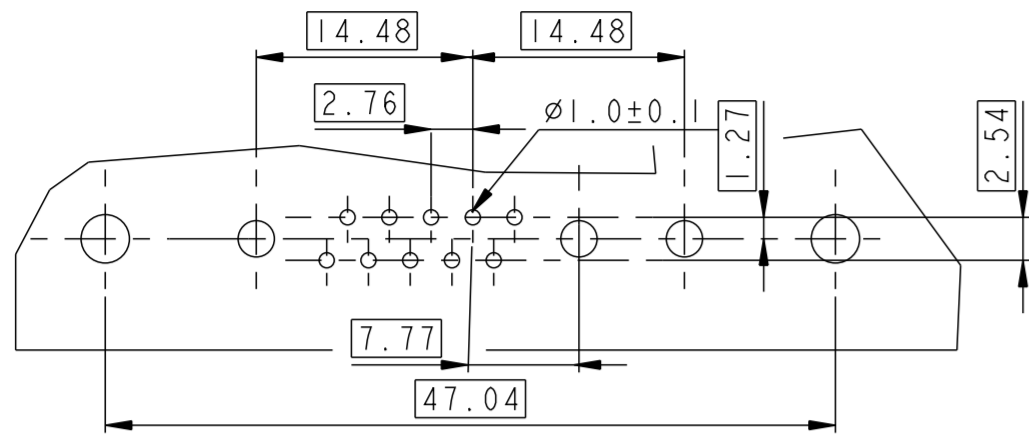

9W4

LAYOUT AND CONNECTOR DIMENSIONS
For PCB hole diameters see table I sheet I

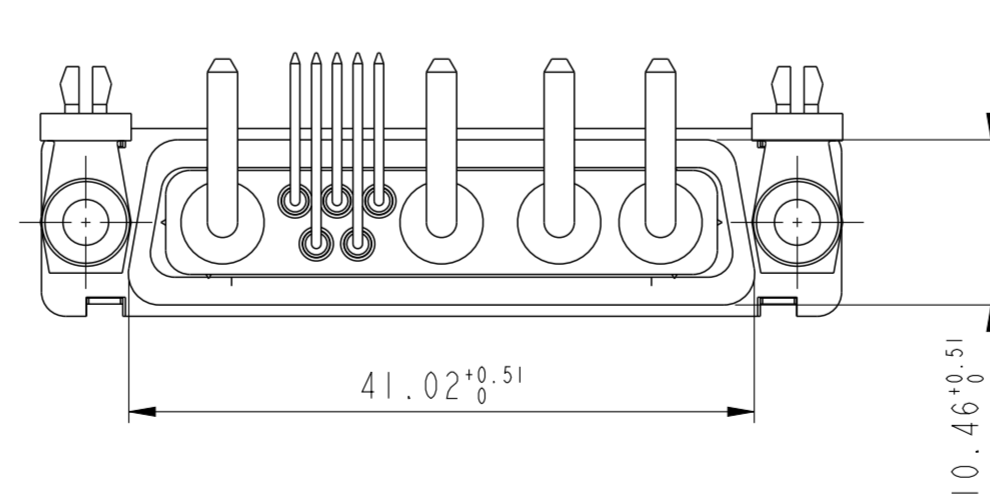
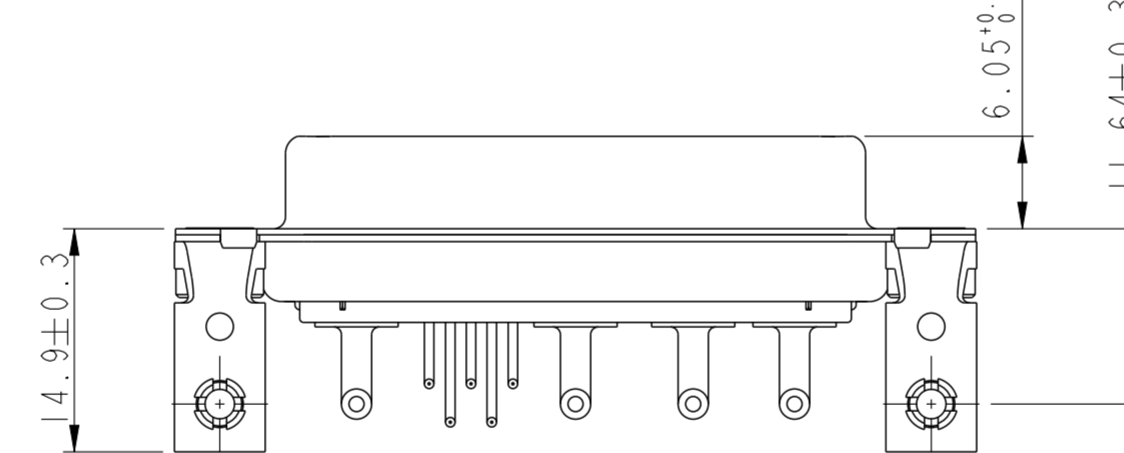
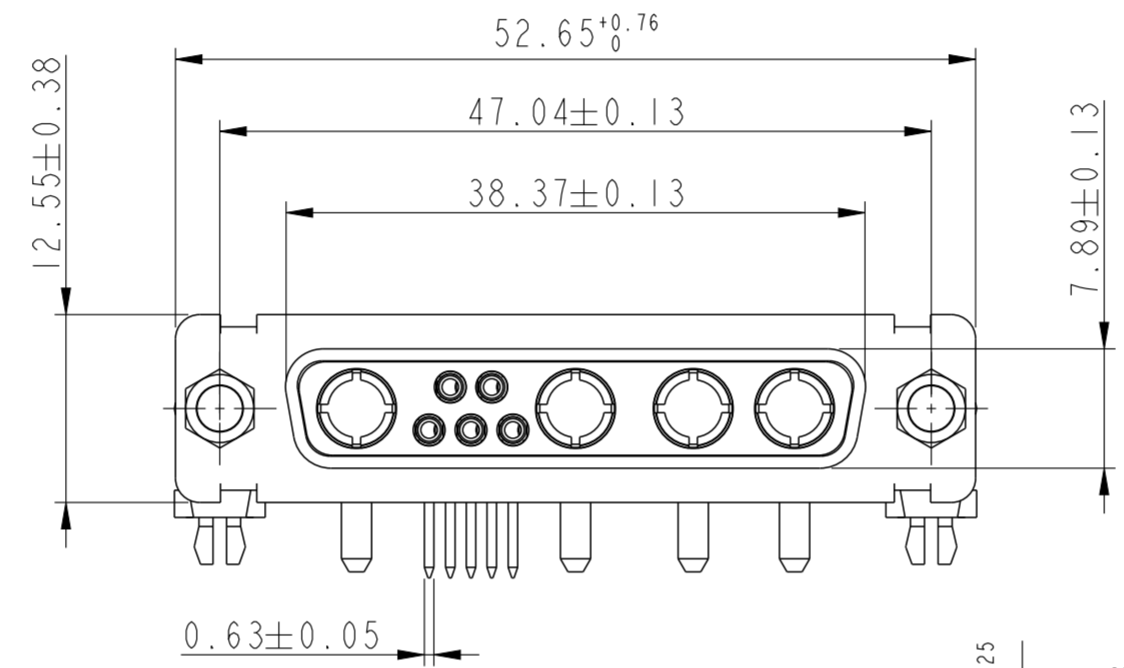
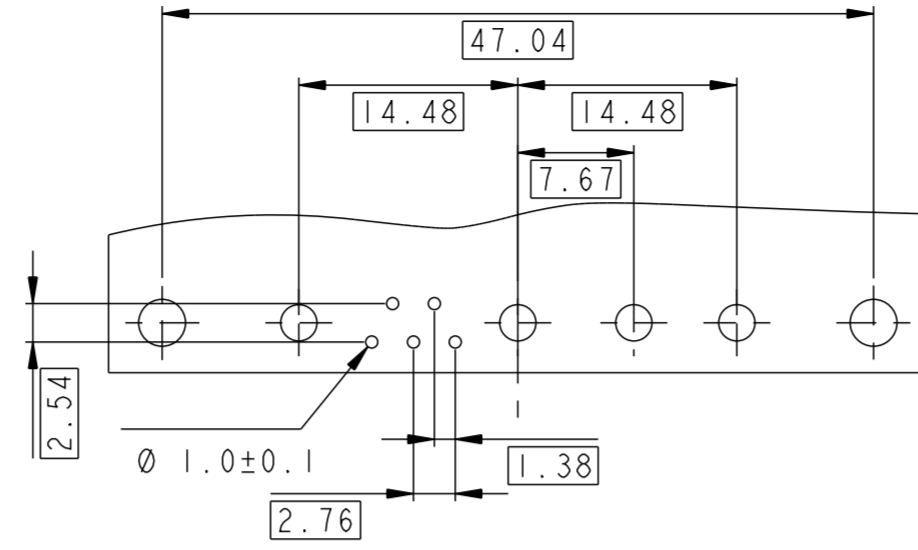

Floating signal contacts

17W2

LAYOUT AND CONNECTOR DIMENSIONS
For PCB hole diameters see table I sheet I

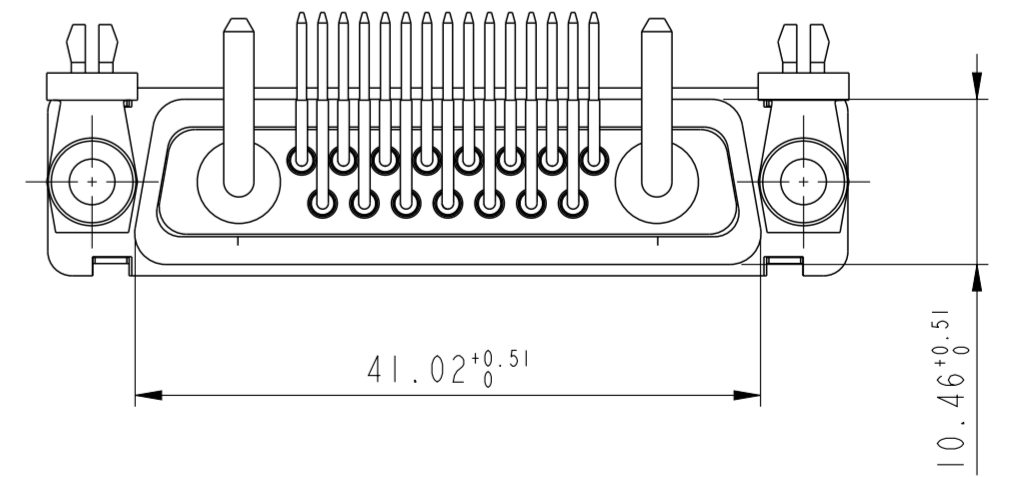
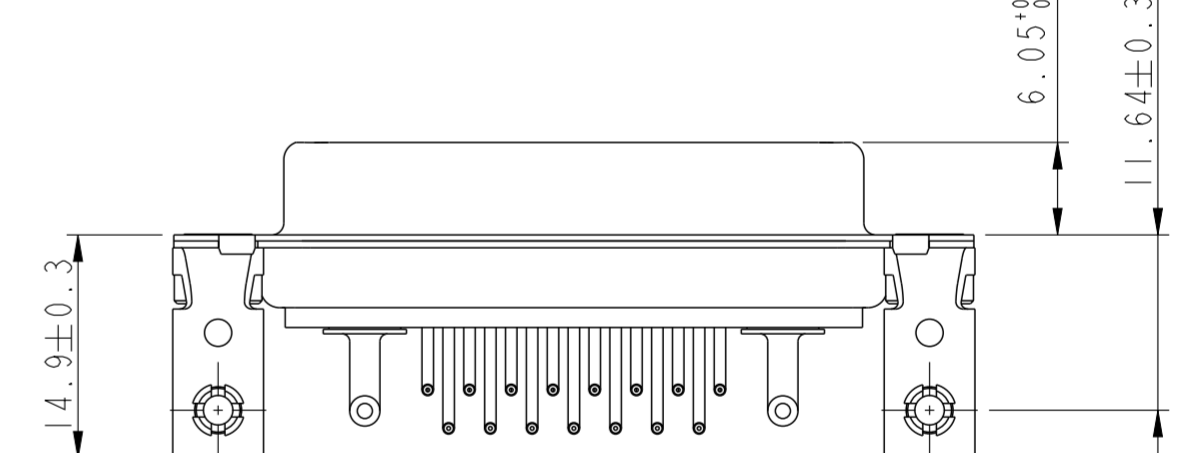
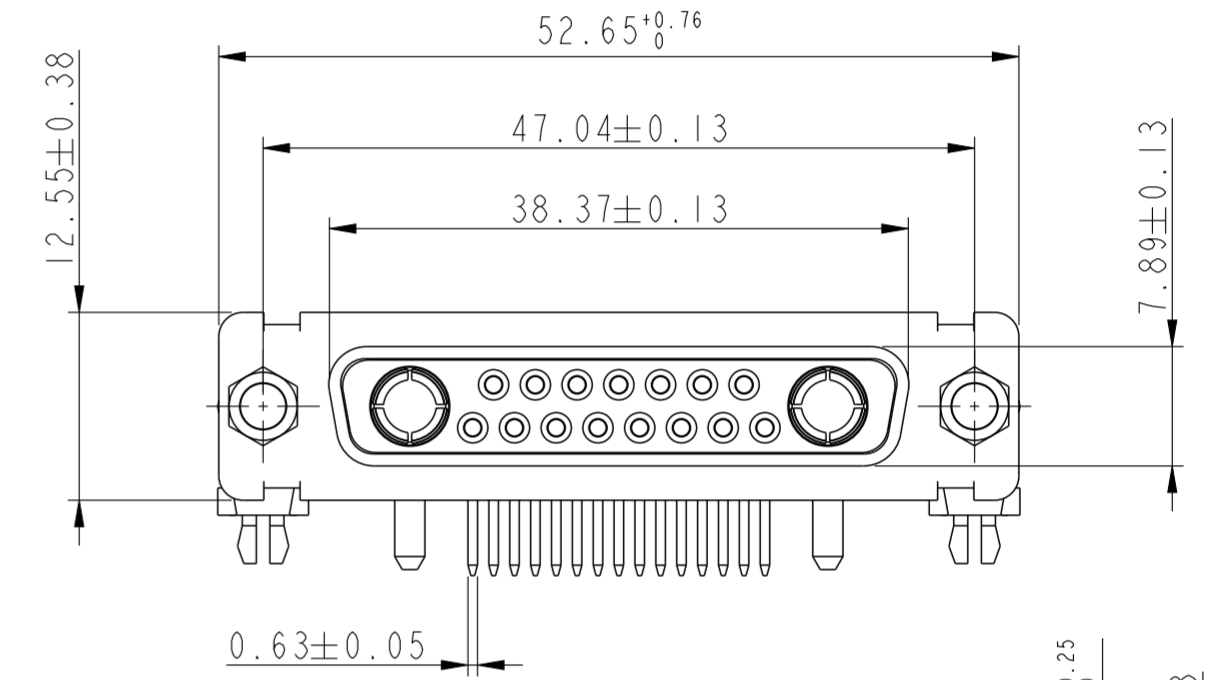
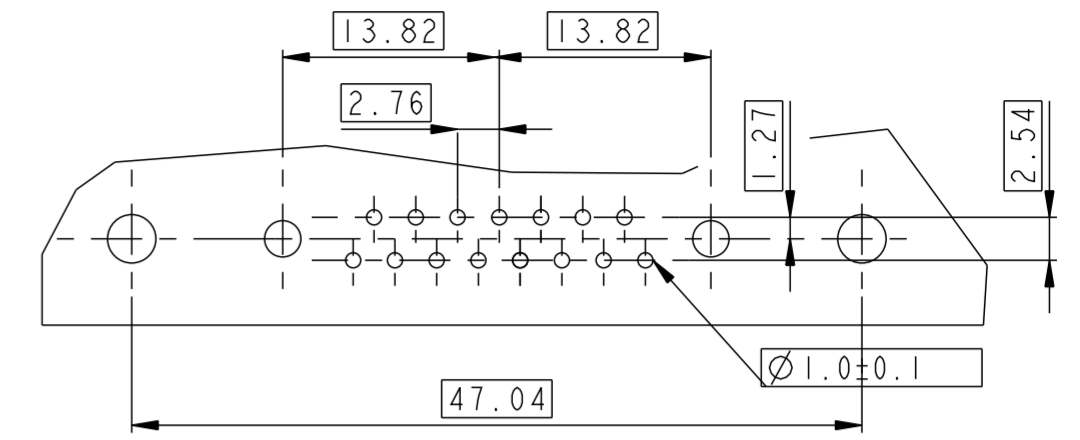

dr	GREGAR M	2019-01-07	projection	MM	size	A2	scale	1:1
eng	MITHUN PAUL	2019-01-07			ecn no	ELX+32326	rev	F
chr	-	-						
appr	BIJU K PAUL	2019-01-07	product family	-	rel level	-	dwg no	C01-8639-2300
Amphenol FCI			SUB FEMALE DMW EUROPE mixed power right angled solder			sheet 5 of 7		

21W1

LAYOUT AND CONNECTOR DIMENSIONS

For PCB hole diameters see table 1 sheet 1

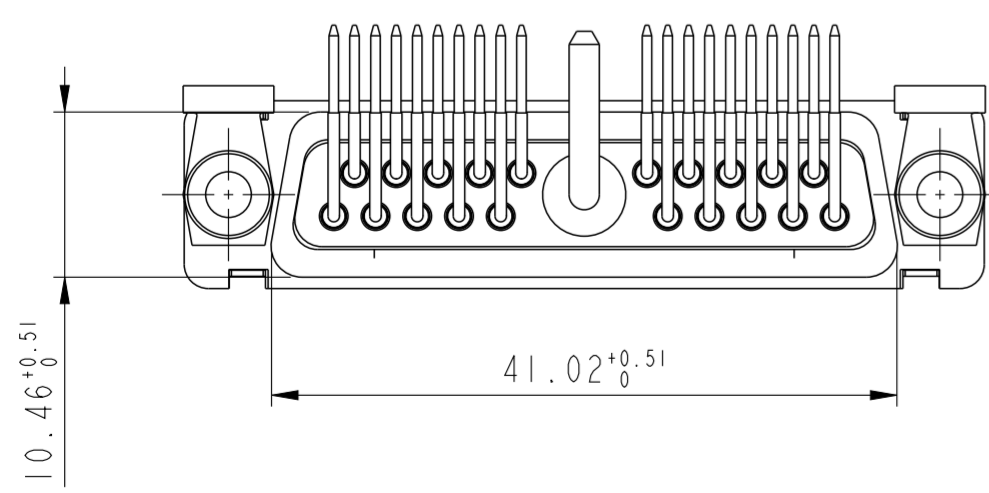
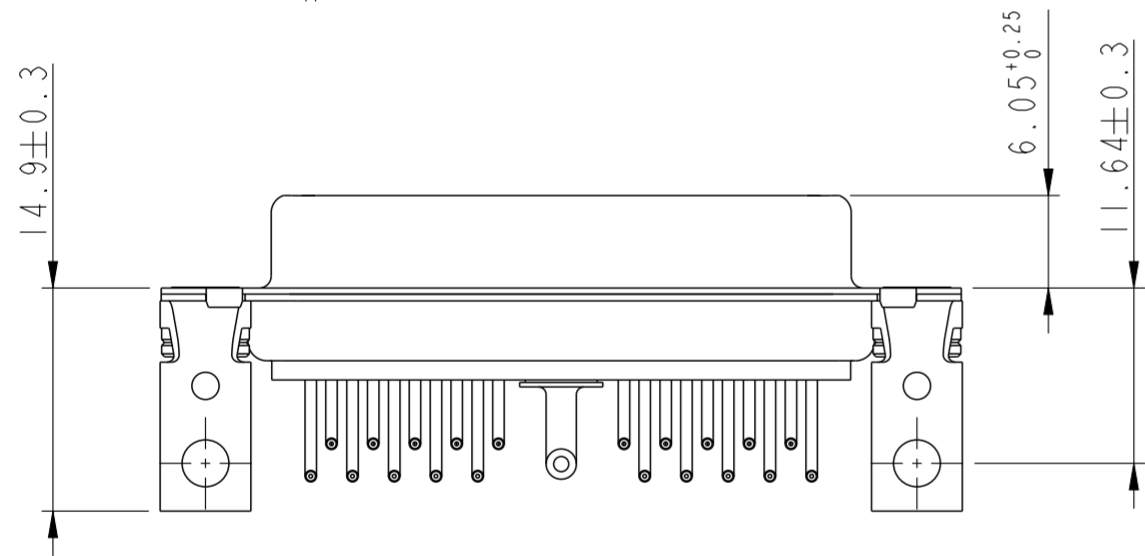
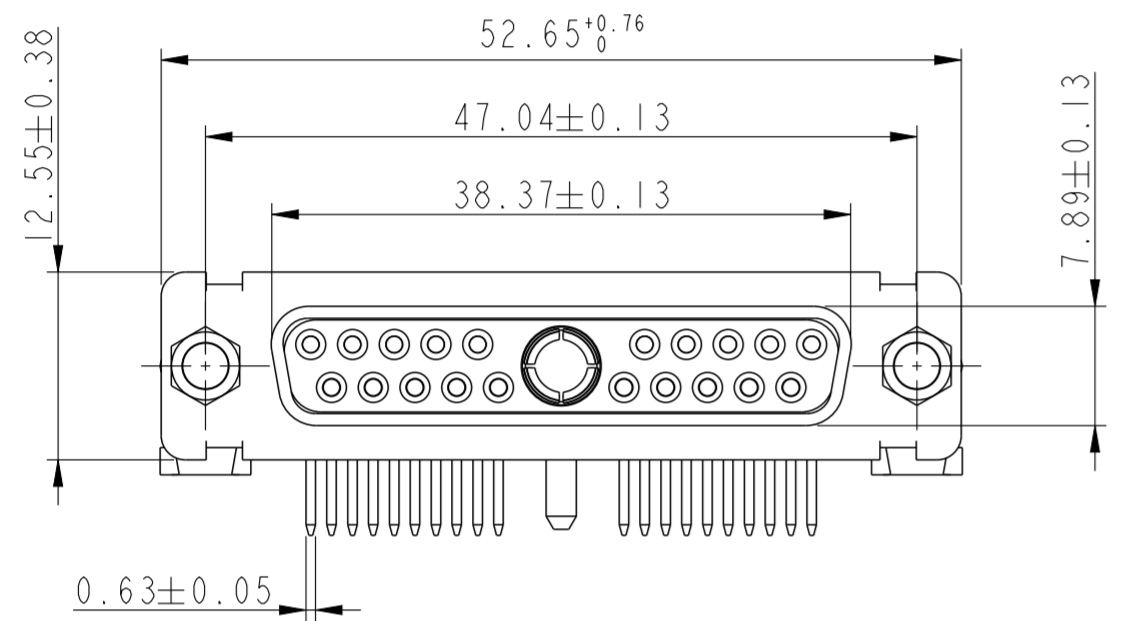
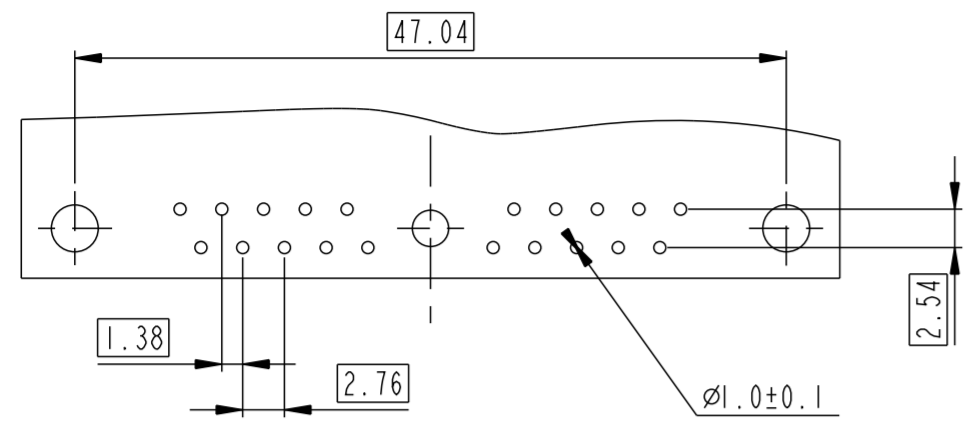

27W2

LAYOUT AND CONNECTOR DIMENSIONS

For PCB hole diameters see table 1 sheet 1

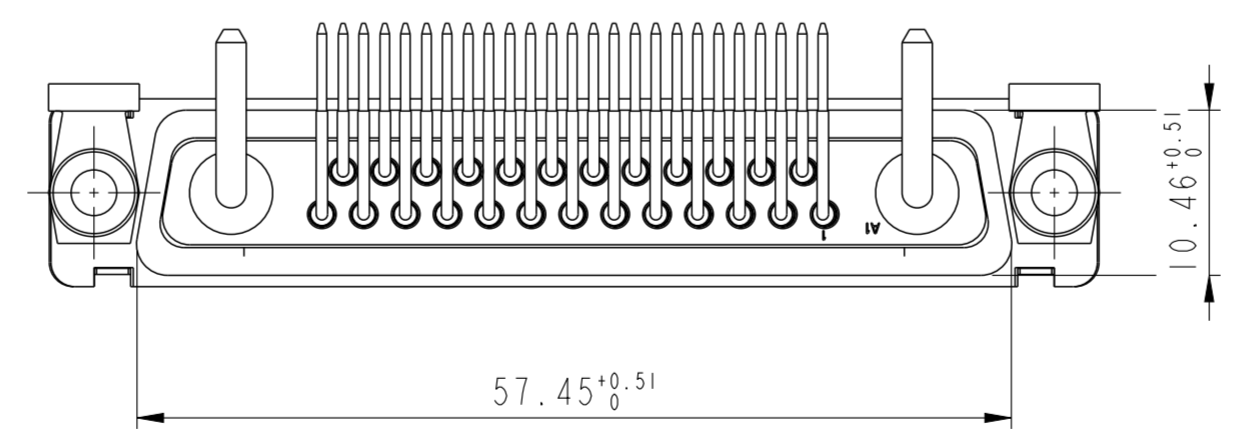
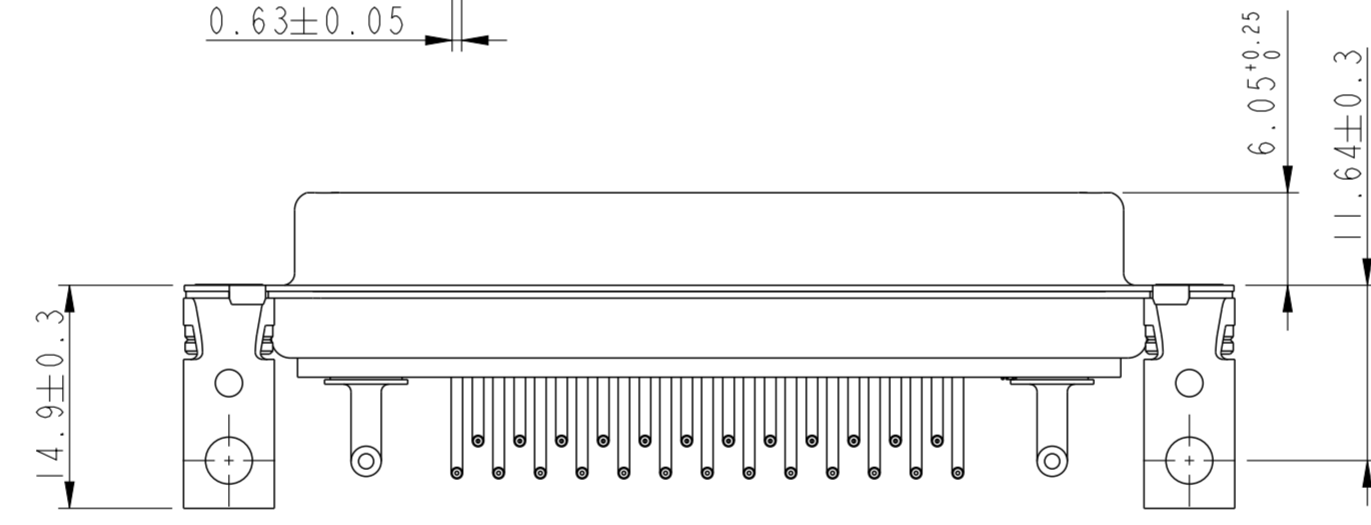
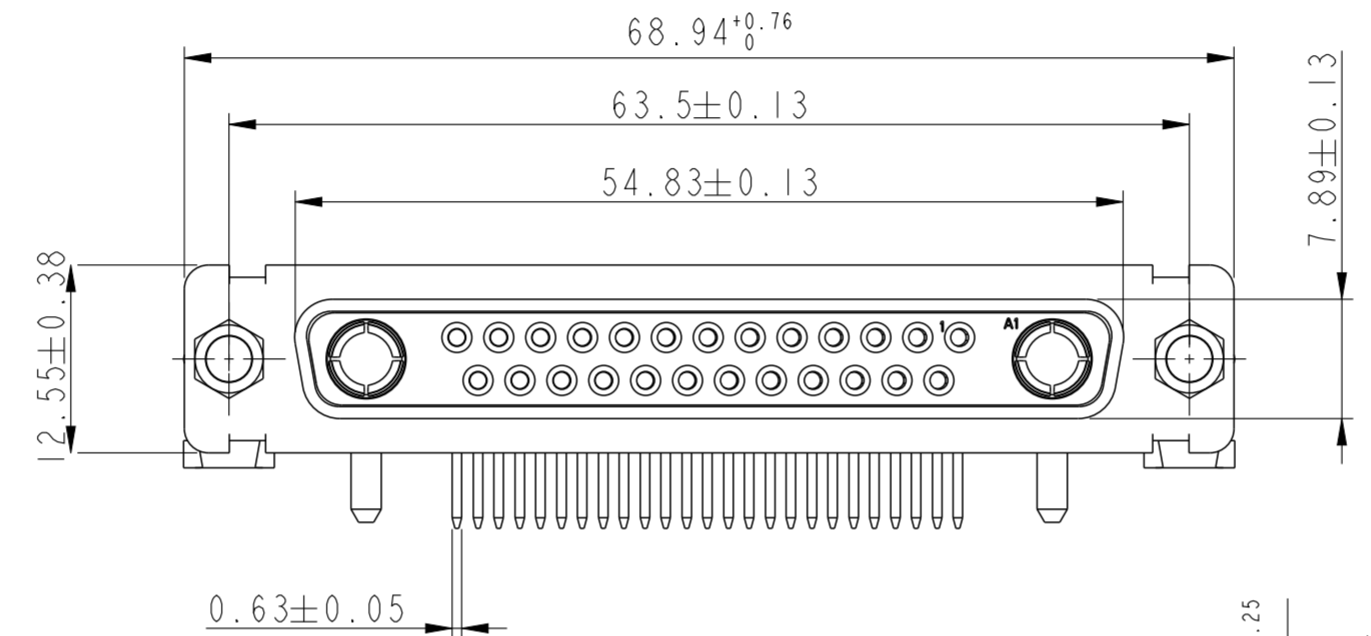
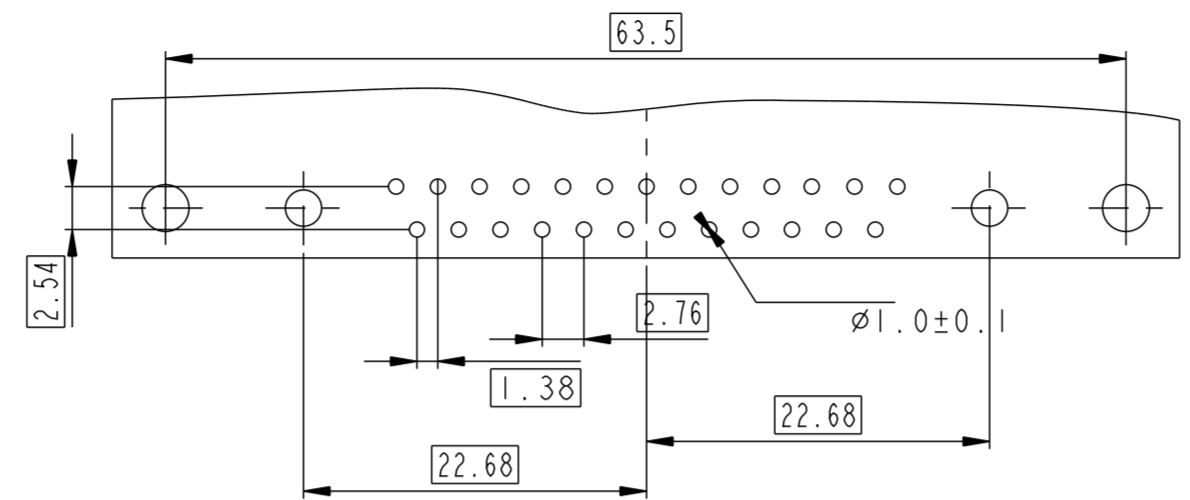

Amphenol
FCi

© 2016 AFci

dr	GREGAR M	2019-01-07	projection	MM	size	A2	scale	1:1
eng	MITHUN PAUL	2019-01-07			ecn no	ELX+32326	rel level	rev
chr	-	-						
appr	BIJU K PAUL	2019-01-07	product family	-	rel level	-	rel level	rev
Amphenol FCI			title SUB FEMALE DMW EUROPE mixed power right angled solder			dwg no C01-8639-2300	sheet 6 of 7	F

PDS: Rev :F

STATUS:Released

Printed: Jan 24, 2019

21WA4

LAYOUT AND CONNECTOR DIMENSIONS

For PCB hole diameters see table I sheet I

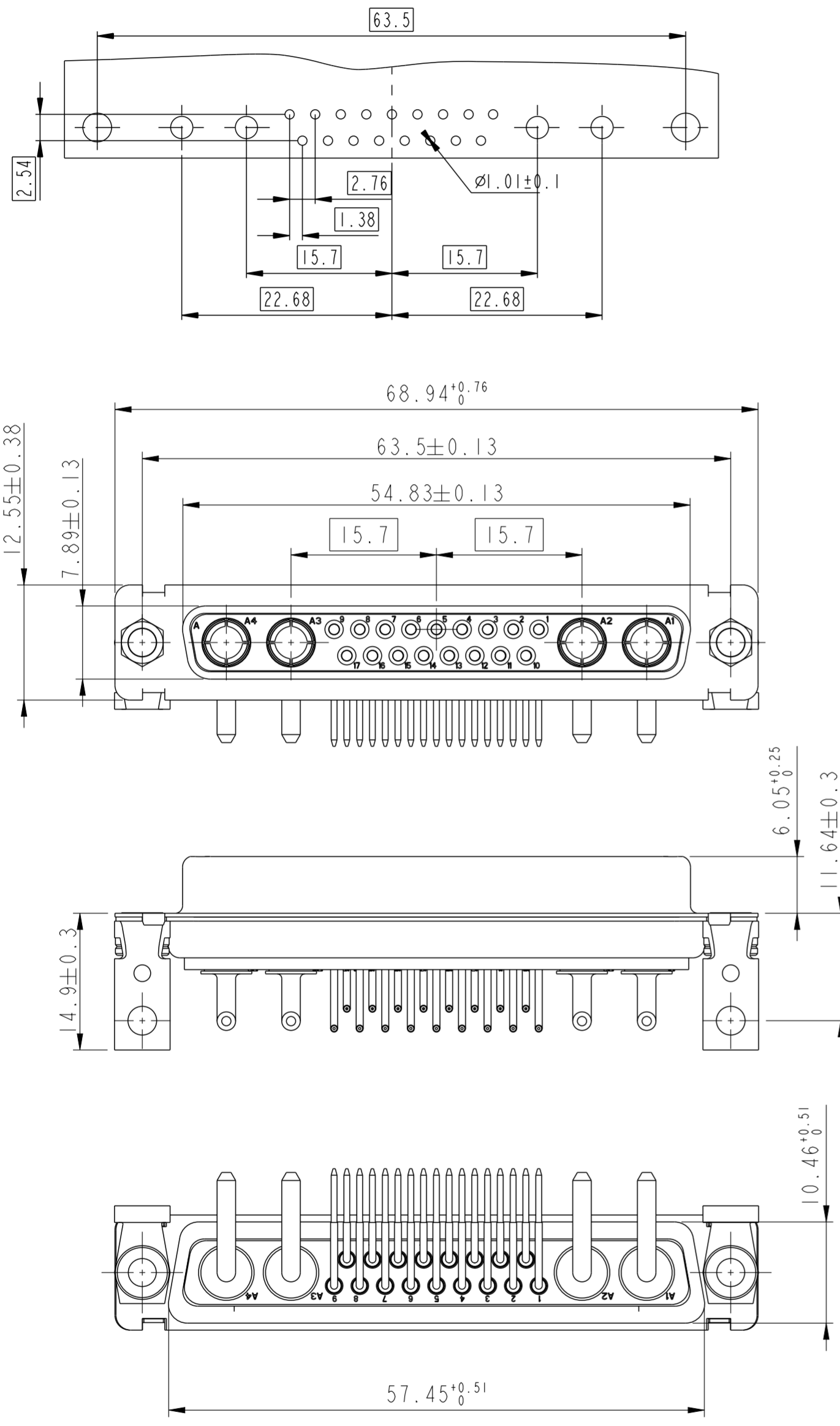

25W3

LAYOUT AND CONNECTOR DIMENSIONS

For PCB hole diameters see table I sheet I

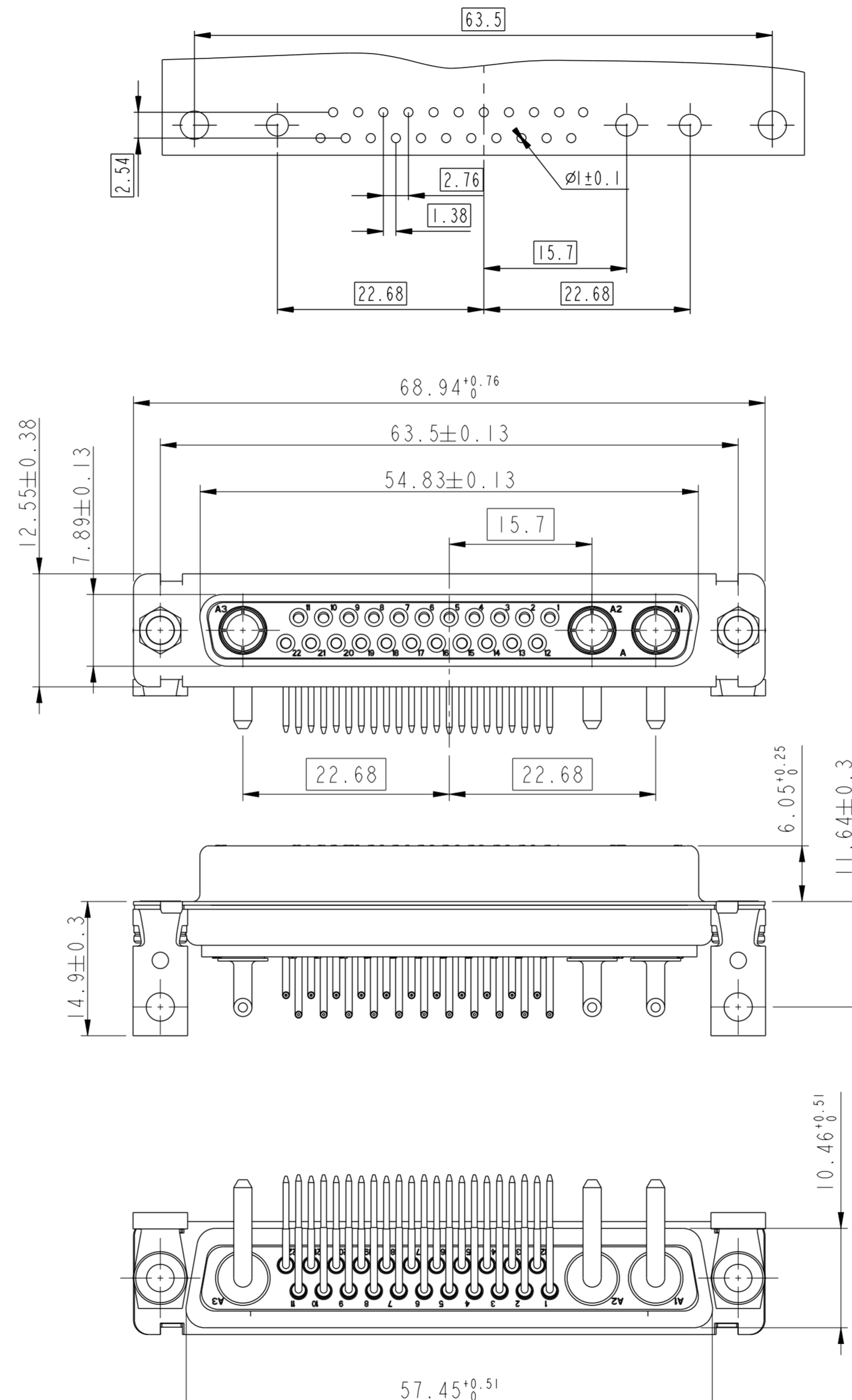

24W7

LAYOUT AND CONNECTOR DIMENSIONS

For PCB hole diameters see table I sheet I

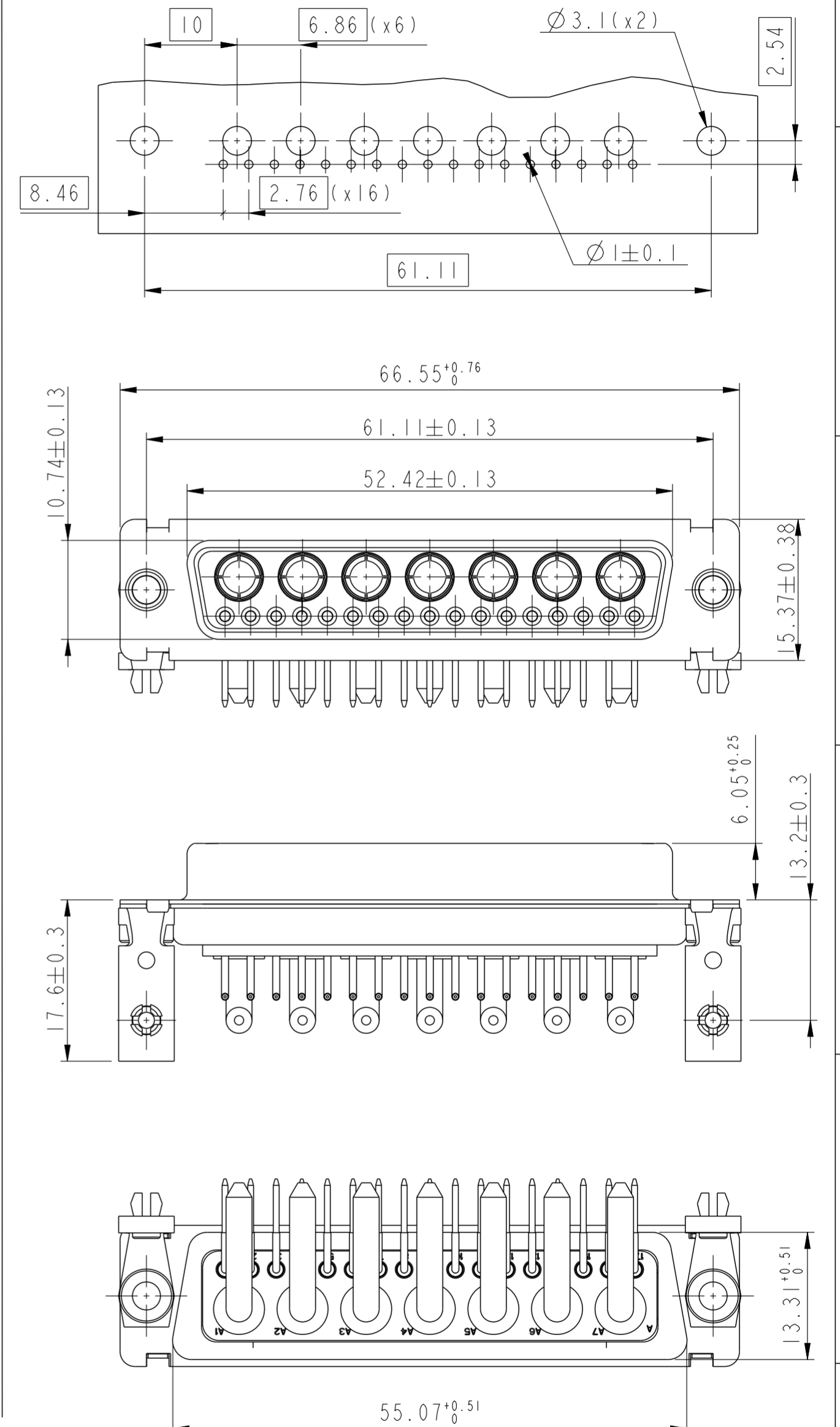

Amphenol
FCi

© 2016 AFci

dr	GREGAR M	2019-01-07	projection	MM	size	A2	scale	1:1
eng	MITHUN PAUL	2019-01-07			ecn no	ELX-32328	rel level	rev
chr	-	-						
appr	BIJU K PAUL	2019-01-07	product family	-	rel level	-	rel level	rev
Amphenol FCI			title SUB FEMALE DMW EUROPE mixed power right angled solder			dwg no C01-8639-2300		F
cat. no.			-			sheet 7 of 7		

PDS: Rev :F

STATUS:Released

Printed: Jan 24, 2019