

REVISIONS			
REV	ECN, ERN NO.	DATE	APPRD.
D	PRODUCT DRAWING	APR29/05	K.L.

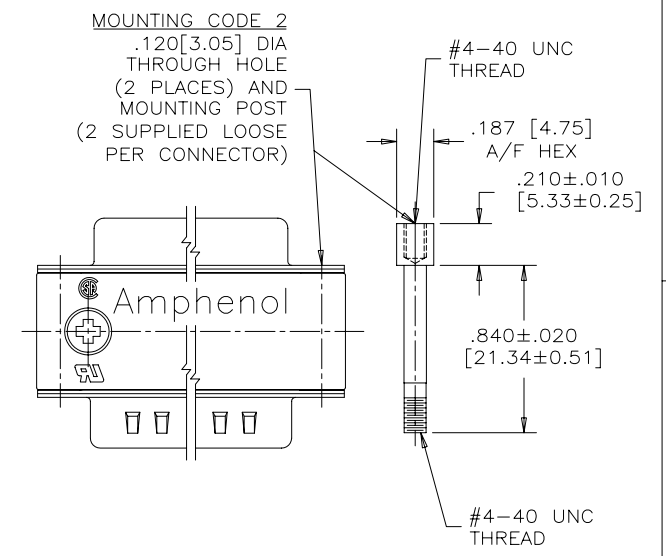
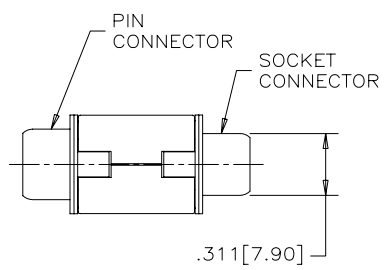
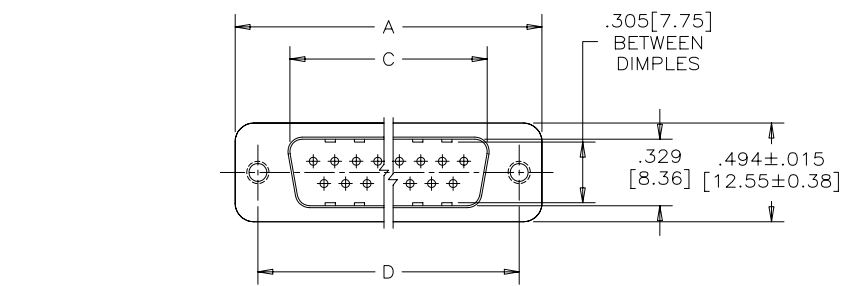
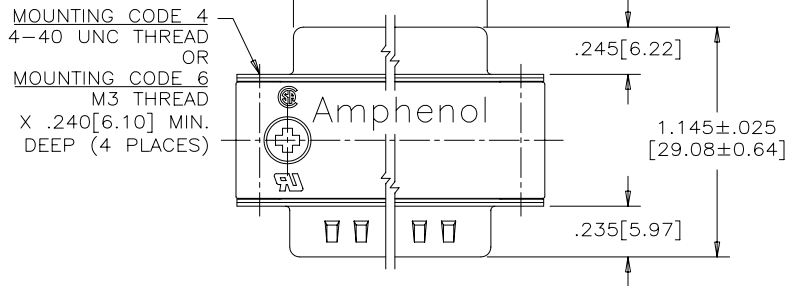

SIZE	A ± .015 [0.38]	B ± .005 [0.13]	C ± .005 [0.13]	D ± .005 [0.13]
E09	1.213 [30.81]	.643 [16.33]	.666 [16.92]	.984 [24.99]
A15	1.541 [39.14]	.971 [24.66]	.994 [25.25]	1.312 [33.32]
B25	2.088 [53.04]	1.511 [38.38]	1.534 [38.96]	1.852 [47.04]
C37	2.729 [69.32]	2.159 [54.84]	2.182 [55.42]	2.500 [63.50]

ORDERING CODE: F C C 1 7 - E 0 9 A D - 4 F 0 G

SERIES _____

SIZE/NUMBER OF CONTACTS _____
E09, A15, B25, OR C37

CONNECTOR STYLE _____
AD=PIN/SOCKET ADAPTER

MOUNTING _____
2=.120 [3.05] DIA. THROUGH HOLE WITH MOUNTING POST
3=OLD DESIGNATION FOR #4-40 THREAD - USE MOUNTING CODE 4.
4=#4-40 UNC THREAD
6=M3 THREAD

CONTACT FINISH/GOLD THICKNESS _____
NO DIGIT=STANDARD 15 MICRONS [0.38 MICRONS] GOLD
G=50 MICRONS [1.27 MICRONS] GOLD

MODIFIER _____
0=STANDARD

FILTER CAPACITANCE _____
D=50 pF 4=820 pF
B=100 pF 5=1000 pF
0=180 pF 7=1200 pF
F=330 pF E=2200 pF
L=380 pF 9=5600 pF
1=470 pF 8=47000 pF

REFER TO AMPHENOL CATALOGUE FOR FILTER PERFORMANCE CHARACTERISTICS

- NOTES:**
- MATERIALS: - SHELLS - TIN PLATED STEEL
- CONTACTS - PHOSPHOR BRONZE PLATED WITH GOLD OVER NICKEL ON THE MATING AREA.
- INSULATOR - ENGINEERING THERMOPLASTIC, FLAMMABILITY RATING UL94V-0, BLACK.
- OUTSIDE SHELLS: ZINC DIECAST, TIN PLATED
 - INSULATION RESISTANCE: 3000 MEGOHMS MINIMUM
 - CURRENT RATING: 5 AMPS MAXIMUM
2 AMPS FILTERING MAXIMUM
 - OPERATING TEMPERATURE: -40°C TO 85°C.
 - TOLERANCE, UNLESS INDICATED OTHERWISE, ±.005 [0.13].

THIS DOCUMENT CONTAINS PROPRIETARY INFORMATION AND SUCH INFORMATION MAY NOT BE DISCLOSED TO OTHERS FOR ANY PURPOSE OR USED FOR MANUFACTURING PURPOSES WITHOUT WRITTEN PERMISSION FROM AMPHENOL CANADA CORP.

MATERIAL -----	DRAWN I.ESSAJEE	DATE 99/03/10	Amphenol Canada Corp.
	DESIGNED K.LAMBIE	99/03/09	
	CHECKED		
	I. E. APPRD.		
FINISH -----	Q. A. APPRD.		TITLE FCC17 SERIES MALE/FEMALE ADAPTER
	DWG. APPRD.		DWG DRAWING NO. C P-FCC17-XXXAD-XXOX
	ENG. REL. NO.		REV. D
	REF. EAR C10727		SCALE 2/1
DIMENSIONS ARE IN INCHES [mm]		CODE ID. NO. 03554	WT. ----- SURF. ----- SHEET 1 OF 1