

10 9 8 7 6 5 4 3 2 1

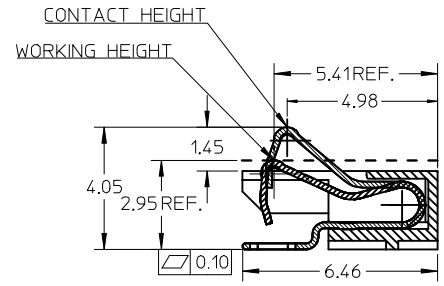

SECTION A-A

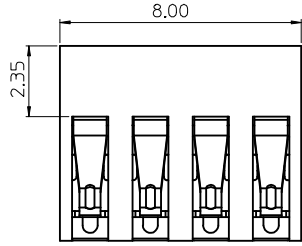
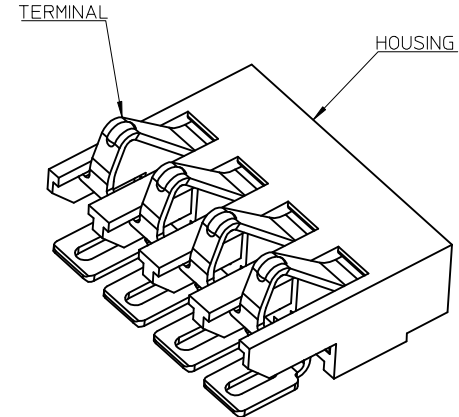
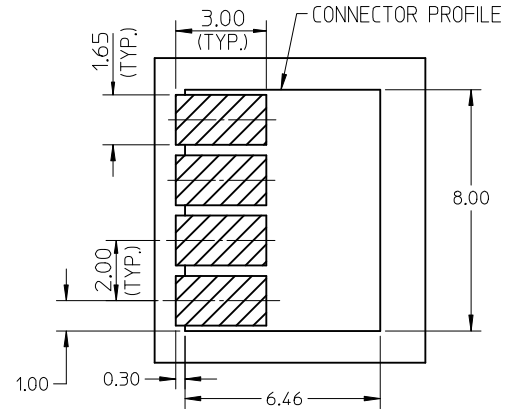
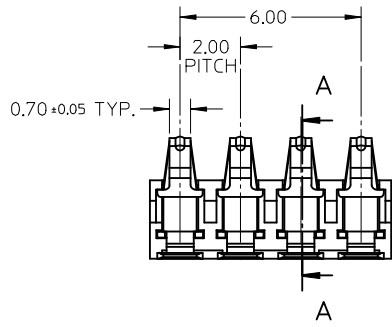

RECOMMENDED FOOT PRINT

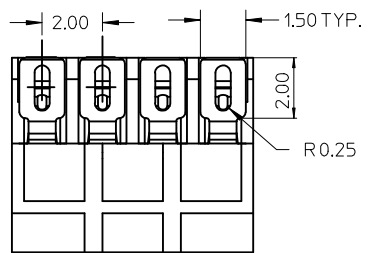

- NOTE:
- MATERIAL:
HOUSING: HIGH TEMPERATURE THERMOPLASTIC.COLOR:BLACK
TERMINAL:PHOSPHOR BRONZE C5210-H.
 - FINISH:
CONTACT AREA: 0.75 MICRON GOLD MIN OVER 1.25 MICRON NICKEL MIN.
SOLDER AREA: GOLD FLASH (0.075~0.125 MICRON) OVER 1.25 MICRON NICKEL MIN.
REST AREA: 1.25 MICRON NICKEL MIN.
 - COPLANARITY: 0.1 MAX AMONG THESE SOLDER TAILS AND HOUSING SURFACE.
 - PRODUCT SPECIFICATION: PS-47302-001
 - WORKING HEIGH: DIMENSION 2.95MM

9 8 7 6 5 4 3 2 1

NEW RELEASE EC NO: SH2006-0598 DRW: LSHEN 2006/04/25 CHKD: XIXU 2006/04/25 APPR: XIXU 2006/04/26	QUALITY SYMBOLS ▽=0 ◻=0	GENERAL TOLERANCES (UNLESS SPECIFIED)		DIMENSION STYLE MM ONLY	SCALE 5:1	DESIGN UNITS METRIC	THIRD ANGLE PROJECTION		
		4 PLACES ± --- ± ---	mm INCH	DRAWN BY SSUN	DATE 2005/07/08	TITLE 2.0MM PITCH 4 CIRCUITS 0.7MM CONTACT WIDTH BATTERY CONNECTOR			
		3 PLACES ± --- ± ---		CHECKED BY YJWU	DATE 2005/07/08	MOLEX INCORPORATED			
		2 PLACES ± 0.15 ± --- 1 PLACE ± 0.20 ± ---		APPROVED BY VINCENT YAP	DATE 2005/07/08	MATERIAL NO. 473020001	DOCUMENT NO. SD-47302-001	SHEET NO. 1 OF 1	
		ANGULAR ± 2 °		DRAFT WHERE APPLICABLE MUST REMAIN WITHIN DIMENSIONS					