

# LM3352

## Regulated 200 mA Buck-Boost Switched Capacitor DC/DC Converter

### General Description

The LM3352 is a CMOS switched capacitor DC/DC converter that produces a regulated output voltage by automatically stepping up (boost) or stepping down (buck) the input voltage. It accepts an input voltage between 2.5V and 5.5V. The LM3352 is available in three standard output voltage versions: 2.5V, 3.0V and 3.3V. If other output voltage options between 1.8V and 4.0V are desired, please contact your National Semiconductor representative.

The LM3352's proprietary buck-boost architecture enables up to 200 mA of load current at an average efficiency greater than 80%. Typical operating current is only 400  $\mu$ A and the typical shutdown current is only 2.5  $\mu$ A.

The LM3352 is available in a 16-pin TSSOP package. This package has a maximum height of only 1.1 mm.

The high efficiency of the LM3352, low operating and shutdown currents, small package size, and the small size of the overall solution make this device ideal for battery powered, portable, and hand-held applications.

### Features

- Regulated  $V_{OUT}$  with  $\pm 3\%$  accuracy
- Standard output voltage options: 2.5V, 3.0V and 3.3V

- Custom output voltages available from 1.8V to 4.0V in 100 mV increments
- 2.5V to 5.5V input voltage
- Up to 200 mA output current
- >80% average efficiency
- Uses few, low-cost external components
- Very small solution size
- 400  $\mu$ A typical operating current
- 2.5  $\mu$ A typical shutdown current
- 1 MHz switching frequency (typical)
- Architecture and control methods provide high load current and good efficiency
- TSSOP-16 package
- Over-temperature protection

### Applications

- 1-cell Lilon battery-operated equipment including PDAs, hand-held PCs, cellular phones
- Flat panel displays
- Hand-held instruments
- NiCd, NiMH, or alkaline battery powered systems
- 3.3V to 2.5V and 5.0V to 3.3V conversion

### Typical Operating Circuit

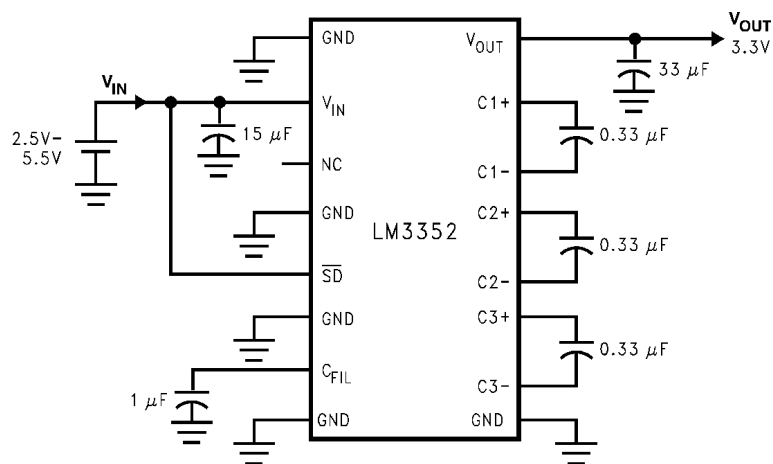

DS101037-1

## Connection Diagram

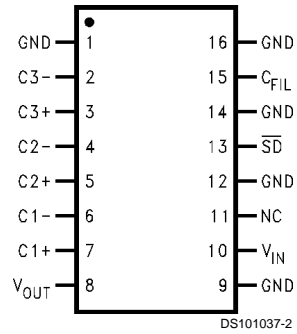

**Top View**  
**TSSOP-16 Pin Package**  
 See NS Package Number MTC16

## Ordering Information

Order Number	Package Type	NSC Package Drawing	Supplied As
LM3352MTCX-2.5	TSSOP-16	MTC16	2.5k Units, Tape and Reel
LM3352MTC-2.5	TSSOP-16	MTC16	94 Units, Rail
LM3352MTCX-3.0	TSSOP-16	MTC16	2.5k Units, Tape and Reel
LM3352MTC-3.0	TSSOP-16	MTC16	94 Units, Rail
LM3352MTCX-3.3	TSSOP-16	MTC16	2.5k Units, Tape and Reel
LM3352MTC-3.3	TSSOP-16	MTC16	94 Units, Rail

## Pin Description

Pin Number	Name	Function
1	GND	Ground*
2	C3-	Negative Terminal for C3
3	C3+	Positive Terminal for C3
4	C2-	Negative Terminal for C2
5	C2+	Positive Terminal for C2
6	C1-	Negative Terminal for C1
7	C1+	Positive Terminal for C1
8	V <sub>OUT</sub>	Regulated Output Voltage
9	GND	Ground*
10	V <sub>IN</sub>	Input Supply Voltage
11	NC	This pin must be left unconnected.
12	GND	Ground*
13	$\overline{SD}$	Active Low CMOS Logic-Level Shutdown Input
14	GND	Ground*
15	C <sub>FIL</sub>	Filter Capacitor; A 1 $\mu$ F ceramic capacitor is suggested.
16	GND	Ground*

\*All GND pins of the LM3352 must be connected to the same ground.

**Absolute Maximum Ratings** (Note 1)

If Military/Aerospace specified devices are required, please contact the National Semiconductor Sales Office/Distributors for availability and specifications.

$V_{OUT}$ Pin	-0.5V to 4.5V
All Other Pins	-0.5V to 5.6V
Power Dissipation ( $T_A = 25^\circ\text{C}$ ) (Note 2)	700 mW
$T_{JMAX}$ (Note 2)	150°C
$\theta_{JA}$ (Note 2)	150°C/W
Storage Temperature	-65°C to +150°C

Lead Temperature (Soldering, 5 sec.)	260°C
ESD Rating (Note 3)	
human body model	2 kV
machine model	100V

**Operating Ratings**

Input Voltage ( $V_{IN}$ )	2.5V to 5.5V
Output Voltage ( $V_{OUT}$ )	1.8V to 4.0V
Ambient Temperature ( $T_A$ ) (Note 2)	-40°C to +85°C
Junction Temperature ( $T_J$ ) (Note 2)	-40°C to +125°C

**Electrical Characteristics**

Limits in standard typeface are for  $T_J = 25^\circ\text{C}$ , and limits in **boldface** type apply over the full operating temperature range. Unless otherwise specified:  $C_1 = C_2 = C_3 = 0.33 \mu\text{F}$ ;  $C_{IN} = 15 \mu\text{F}$ ;  $C_{OUT} = 33 \mu\text{F}$ ;  $V_{IN} = 3.5\text{V}$ .

Parameter	Conditions	Min	Typ	Max	Units
<b>LM3352-2.5</b>					
Output Voltage ( $V_{OUT}$ )	$V_{IN} = 3.5\text{V}$ ; $I_{LOAD} = 100 \text{ mA}$	2.463	2.5	2.537	V
	$2.8\text{V} < V_{IN} < 5.5\text{V}$ ; $1 \text{ mA} < I_{LOAD} < 100 \text{ mA}$	2.425/ <b>2.400</b>	2.5	2.575/ <b>2.600</b>	
	$3.6\text{V} < V_{IN} < 4.9\text{V}$ ; $1 \text{ mA} < I_{LOAD} < 200 \text{ mA}$	2.425/ <b>2.400</b>	2.5	2.575/ <b>2.600</b>	
	$4.9\text{V} < V_{IN} < 5.5\text{V}$ ; $1 \text{ mA} < I_{LOAD} < 175 \text{ mA}$	2.425/ <b>2.400</b>	2.5	2.575/ <b>2.600</b>	
Efficiency	$I_{LOAD} = 15 \text{ mA}$		85		%
	$I_{LOAD} = 150 \text{ mA}$ , $V_{IN} = 4.0\text{V}$		75		
Output Voltage Ripple (Peak-to-Peak)	$I_{LOAD} = 50 \text{ mA}$ $C_{OUT} = 33 \mu\text{F}$ tantalum		75		mV <sub>P-P</sub>
<b>LM3352-3.0</b>					
Output Voltage ( $V_{OUT}$ )	$V_{IN} = 3.5\text{V}$ ; $I_{LOAD} = 100 \text{ mA}$	2.955	3.0	3.045	V
	$2.5\text{V} < V_{IN} < 5.5\text{V}$ ; $1 \text{ mA} < I_{LOAD} < 100 \text{ mA}$	2.910/ <b>2.880</b>	3.0	3.090/ <b>3.120</b>	
	$3.8\text{V} < V_{IN} < 5.5\text{V}$ ; $1 \text{ mA} < I_{LOAD} < 200 \text{ mA}$	2.910/ <b>2.880</b>	3.0	3.090/ <b>3.120</b>	
Efficiency	$I_{LOAD} = 15 \text{ mA}$		80		%
	$I_{LOAD} = 150 \text{ mA}$ , $V_{IN} = 4.0\text{V}$		75		
Output Voltage Ripple (Peak-to-Peak)	$I_{LOAD} = 50 \text{ mA}$ $C_{OUT} = 33 \mu\text{F}$ tantalum		75		mV <sub>P-P</sub>
<b>LM3352-3.3</b>					
Output Voltage ( $V_{OUT}$ )	$V_{IN} = 3.5\text{V}$ ; $I_{LOAD} = 100 \text{ mA}$	3.251	3.3	3.349	V
	$2.5\text{V} < V_{IN} < 5.5\text{V}$ ; $1 \text{ mA} < I_{LOAD} < 100 \text{ mA}$	3.201/ <b>3.168</b>	3.3	3.399/ <b>3.432</b>	
	$4.0\text{V} < V_{IN} < 5.5\text{V}$ ; $1 \text{ mA} < I_{LOAD} < 200 \text{ mA}$	3.201/ <b>3.168</b>	3.3	3.399/ <b>3.432</b>	
Efficiency	$I_{LOAD} = 15 \text{ mA}$		90		%
	$I_{LOAD} = 150 \text{ mA}$ , $V_{IN} = 4.0\text{V}$		80		
Output Voltage Ripple (Peak-to-Peak)	$I_{LOAD} = 50 \text{ mA}$ $C_{OUT} = 33 \mu\text{F}$ tantalum		75		mV <sub>P-P</sub>
<b>LM3352-ALL OUTPUT VOLTAGE VERSIONS</b>					
Operating Quiescent Current	Measured at Pin $V_{IN}$ ; $I_{LOAD} = 0\text{A}$ (Note 4)		400	<b>500</b>	$\mu\text{A}$
Shutdown Quiescent Current	SD Pin at 0V (Note 5)		2.5	<b>5</b>	$\mu\text{A}$
Switching Frequency		<b>0.65</b>	1	<b>1.35</b>	MHz
SD Input Threshold Low	$2.5\text{V} < V_{IN} < 5.5\text{V}$			<b>0.2 <math>V_{IN}</math></b>	V

## Electrical Characteristics (Continued)

Limits in standard typeface are for  $T_J = 25^\circ\text{C}$ , and limits in **boldface** type apply over the full operating temperature range. Unless otherwise specified:  $C_1 = C_2 = C_3 = 0.33\ \mu\text{F}$ ;  $C_{IN} = 15\ \mu\text{F}$ ;  $C_{OUT} = 33\ \mu\text{F}$ ;  $V_{IN} = 3.5\text{V}$ .

Parameter	Conditions	Min	Typ	Max	Units
<b>LM3352-ALL OUTPUT VOLTAGE VERSIONS</b>					
SD Input Threshold High	$2.5\text{V} < V_{IN} < 5.5\text{V}$	<b>0.8 <math>V_{IN}</math></b>			V
SD Input Current	Measured at SD Pin; SD Pin = $V_{IN} = 5.5\text{V}$		0.1	1.0	$\mu\text{A}$

**Note 1:** "Absolute Maximum Ratings" indicate limits beyond which damage to the device may occur. Electrical specifications do not apply when operating the device beyond its rated operating conditions.

**Note 2:** As long as  $T_A \leq +85^\circ\text{C}$ , all electrical characteristics hold true for the 3.0V and 3.3V options at all current loads and the 2.5V option at all loads when  $V_{IN} \leq 5\text{V}$ . For  $V_{IN} > 5\text{V}$  with the 2.5V option, the junction temperature rise above ambient is:  $\Delta T = 540I_L - 23$  where  $I_L$  is in amps. The output current must be derated at higher ambient temperatures to make sure  $T_J$  does not exceed  $150^\circ\text{C}$  when operating the 2.5V option at  $V_{IN} > 5\text{V}$ .

**Note 3:** The human body model is a 100 pF capacitor discharged through a 1.5 k $\Omega$  resistor into each pin. The machine model is a 200 pF capacitor discharged directly into each pin.

**Note 4:** The  $V_{OUT}$  pin is forced to 200 mV above the typical  $V_{OUT}$ . This is to insure that the internal switches are off.

**Note 5:** The output capacitor  $C_{OUT}$  is fully discharged before measurement.

## Typical Performance Characteristics Unless otherwise specified $T_A = 25^\circ\text{C}$ .

$V_{OUT}$  vs.  $V_{IN}$

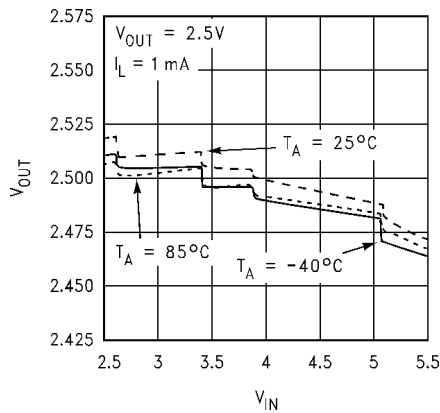

$V_{OUT}$  vs.  $V_{IN}$

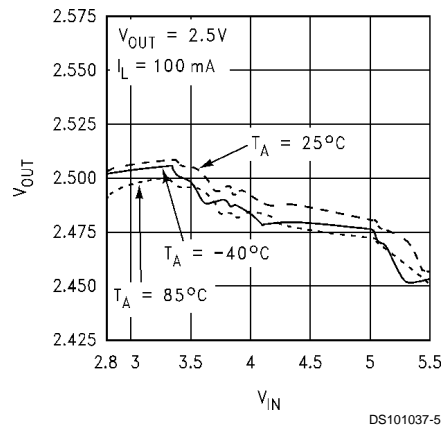

$V_{OUT}$  vs.  $V_{IN}$

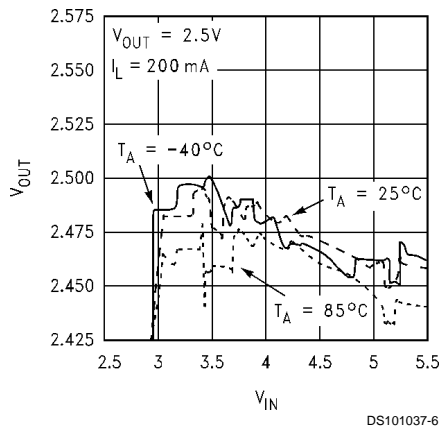

$V_{OUT}$  vs.  $V_{IN}$

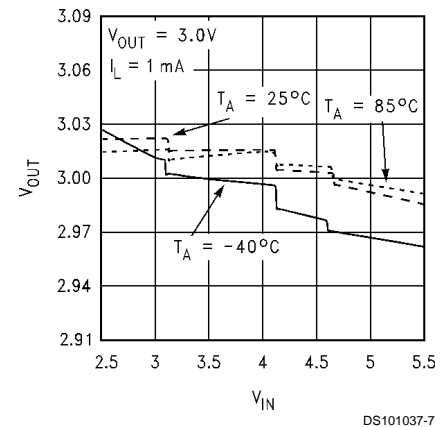

**Typical Performance Characteristics** Unless otherwise specified  $T_A = 25^\circ\text{C}$ . (Continued)

**$V_{OUT}$  vs.  $V_{IN}$**

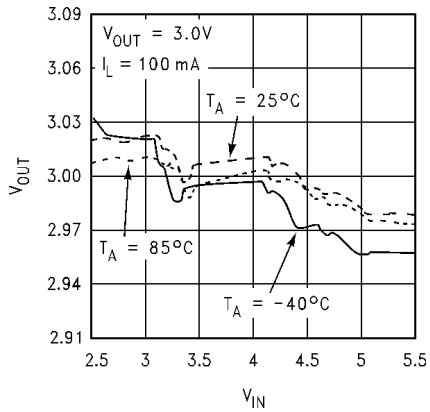

**$V_{OUT}$  vs.  $V_{IN}$**

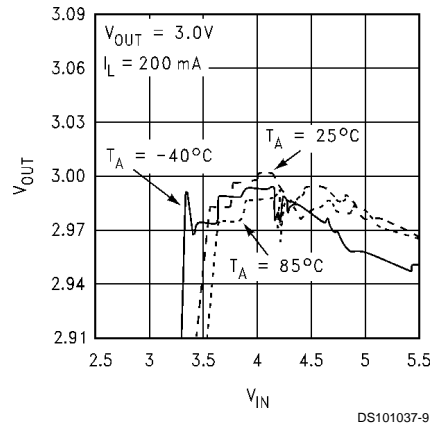

**$V_{OUT}$  vs.  $V_{IN}$**

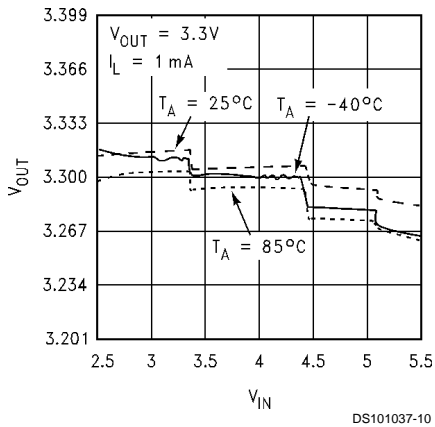

**$V_{OUT}$  vs.  $V_{IN}$**

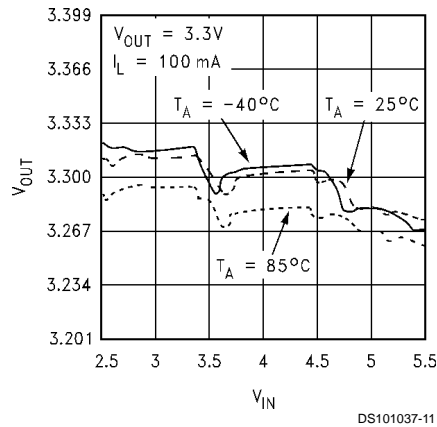

**$V_{OUT}$  vs.  $V_{IN}$**

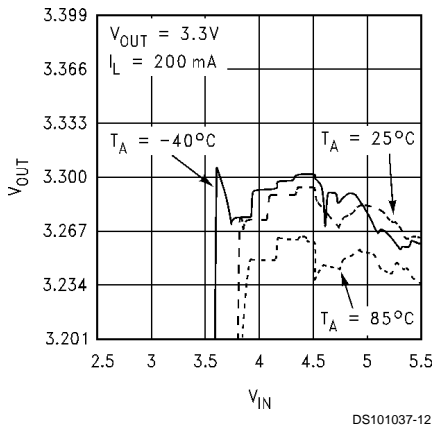

**Load Transient Response**

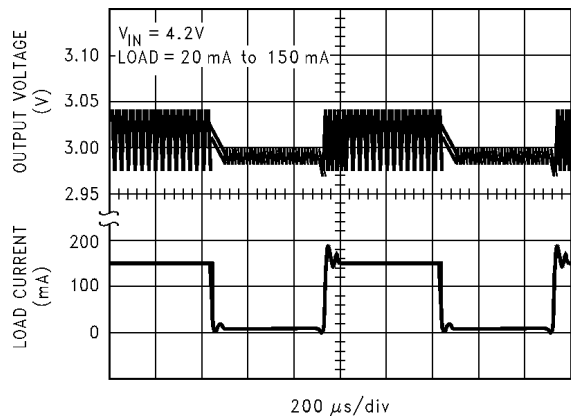

**Typical Performance Characteristics** Unless otherwise specified  $T_A = 25^\circ\text{C}$ . (Continued)

**Efficiency vs.  $V_{IN}$**

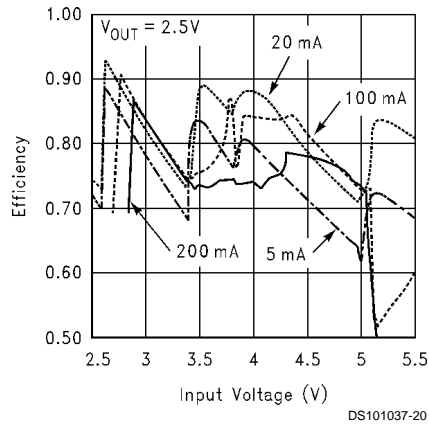

**Efficiency vs.  $V_{IN}$**

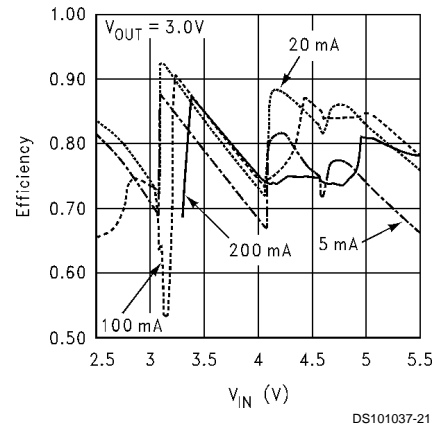

**Efficiency vs.  $V_{IN}$**

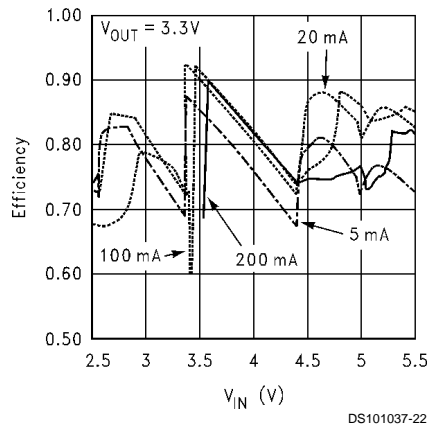

**Switching Frequency vs.  $V_{IN}$**

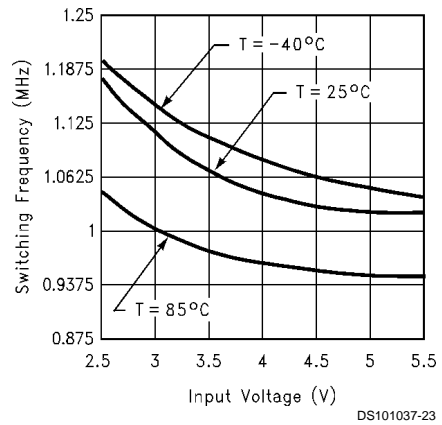

**Operating Quiescent Current vs.  $V_{IN}$**

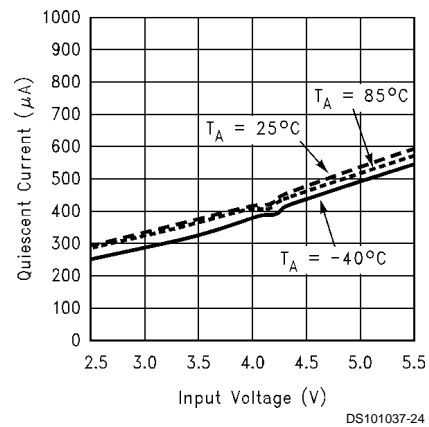

**$V_{OUT}$  Ripple vs.  $C_{OUT}$**

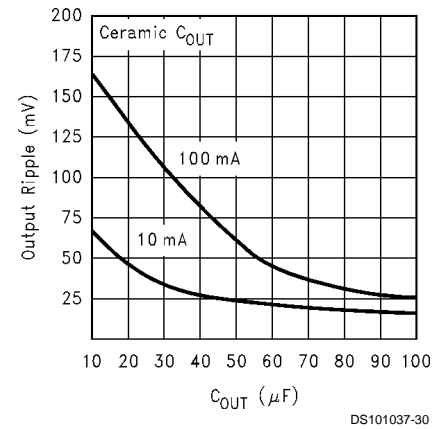

## Typical Performance Characteristics

Unless otherwise specified  $T_A = 25^\circ\text{C}$ . (Continued)

### $V_{\text{OUT}}$ Ripple vs. $C_{\text{OUT}}$

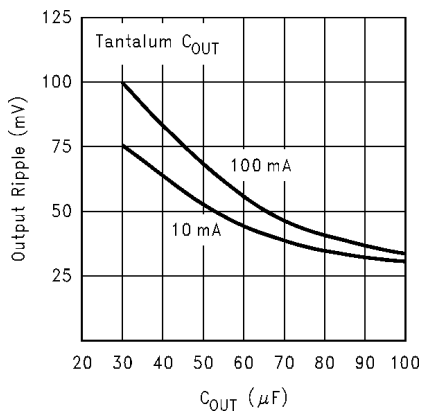

DS101037-31

### $V_{\text{OUT}}$ Ripple vs. $C_{\text{OUT}}$

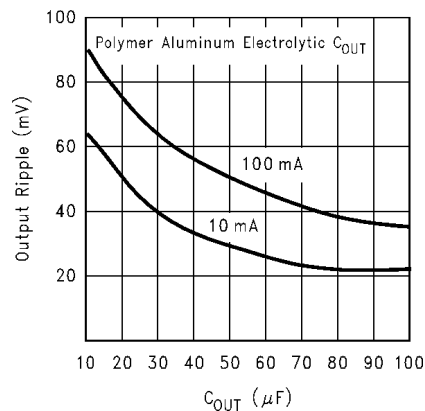

DS101037-32

## Applications Information

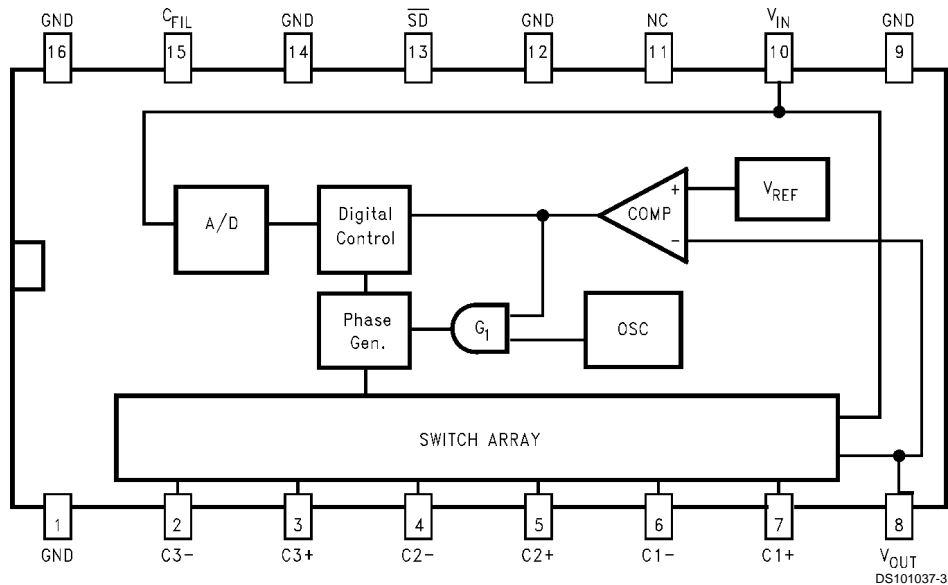

FIGURE 1. Block Diagram

## Operating Principle

The LM3352 is designed to provide a step-up/step-down voltage regulation in battery powered systems. It combines switched capacitor circuitry, reference, comparator, and shutdown logic in a single 16-pin TSSOP package. The LM3352 can provide a regulated voltage between 1.8V and 4V from an input voltage between 2.5V and 5.5V. It can supply a load current up to 200 mA.

As shown in *Figure 1*, the LM3352 employs two feedback loops to provide regulation in the most efficient manner possible. The first loop is from  $V_{\text{OUT}}$  through the comparator COMP, the AND gate  $G_1$ , the phase generator, and the switch array. The comparator's output is high when  $V_{\text{OUT}}$  is less than the reference  $V_{\text{REF}}$ . Regulation is provided by gating the clock to the switch array. In this manner, charge is transferred to the output only when needed. The second loop controls the gain configuration of the switch array. This loop consists of the comparator, the digital control block, the phase generator, and the switch array. The digital control block computes the most efficient gain from a set of seven

gains based on inputs from the A/D and the comparator. The gain signal is sent to the phase generator which then sends the appropriate timing and configuration signals to the switch array. This dual loop provides regulation over a wide range of loads efficiently.

Since efficiency is automatically optimized, the curves for  $V_{\text{OUT}}$  vs.  $V_{\text{IN}}$  and Efficiency vs.  $V_{\text{IN}}$  in the Typical Performance Characteristics section exhibit small variations. The reason is that as input voltage or output load changes, the digital control loops are making decisions on how to optimize efficiency. As the switch array is reconfigured, small variations in output voltage and efficiency result. In all cases where these small variations are observed, the part is operating correctly; minimizing output voltage changes and optimizing efficiency.

## Charge Pump Capacitor Selection

A 0.33  $\mu\text{F}$  ceramic capacitor is suggested for C1, C2 and C3. To ensure proper operation over temperature variations, an X7R dielectric material is recommended.

## Filter Capacitor Selection

### a) CAPACITOR TECHNOLOGIES

The three major technologies of capacitors that can be used as filter capacitors for LM3352 are: i) tantalum, ii) ceramic and iii) polymer electrolytic technologies.

#### i) Tantalum

Tantalum capacitors are widely used in switching regulators. Tantalum capacitors have the highest CV rating of any technology; as a result, high values of capacitance can be obtained in relatively small package sizes. It is also possible to obtain high value tantalum capacitors in very low profile (<1.2 mm) packages. This makes the tantalums attractive for low-profile, small size applications. Tantalums also possess very good temperature stability; i.e., the change in the capacitance value, and impedance over temperature is relatively small. However, the tantalum capacitors have relatively high ESR values which can lead to higher voltage ripple and their frequency stability (variation over frequency) is not very good, especially at high frequencies (>1 MHz).

#### ii) Ceramic

Ceramic capacitors have the lowest ESR of the three technologies and their frequency stability is exceptionally good. These characteristics make the ceramics an attractive

choice for low ripple, high frequency applications. However, the temperature stability of the ceramics is bad, except for the X7R and X5R dielectric types. High capacitance values (>1  $\mu\text{F}$ ) are achievable from companies such as Taiyo-yuden which are suitable for use with regulators. Ceramics are taller and larger than the tantalums of the same capacitance value.

#### iii) Polymer Electrolytic

Polymer electrolytic is a third suitable technology. Polymer capacitors provide some of the best features of both the ceramic and the tantalum technologies. They provide very low ESR values while still achieving high capacitance values. However, their ESR is still higher than the ceramics, and their capacitance value is lower than the tantalums of the same size. Polymers offer good frequency stability (comparable to ceramics) and good temperature stability (comparable to tantalums). The Aluminum Polymer Electrolytics offered by Cornell-Dubilier and Panasonic, and the POS-CAPs offered by Sanyo fall under this category.

Table 1 compares the features of the three capacitor technologies.

TABLE 1. Comparison of Capacitor Technologies

	Ceramic	Tantalum	Polymer Electrolytic
ESR	Lowest	High	Low
Relative Height	Low for Small Values (<10 $\mu\text{F}$ ); Taller for Higher Values	Lowest	Low
Relative Footprint	Large	Small	Largest
Temperature Stability	X7R/X5R-Acceptable	Good	Good
Frequency Stability	Good	Acceptable	Good
$V_{\text{OUT}}$ Ripple Magnitude @ <50 mA	Low	High	Low
$V_{\text{OUT}}$ Ripple Magnitude @ >100 mA	Low	Slightly Higher	Low
$dv/dt$ of $V_{\text{OUT}}$ Ripple @ All Loads	Lowest	High	Low

### b) CAPACITOR SELECTION

#### i) Output Capacitor ( $C_{\text{OUT}}$ )

The output capacitor  $C_{\text{OUT}}$  directly affects the magnitude of the output ripple voltage so  $C_{\text{OUT}}$  should be carefully selected. The graphs titled  $V_{\text{OUT}}$  Ripple vs.  $C_{\text{OUT}}$  in the Typical Performance Characteristics section show how the ripple voltage magnitude is affected by the  $C_{\text{OUT}}$  value and the capacitor technology. These graphs are taken at the gain at which worst case ripple is observed. In general, the higher the value of  $C_{\text{OUT}}$ , the lower the output ripple magnitude. At lighter loads, the low ESR ceramics offer a much lower  $V_{\text{OUT}}$  ripple than the higher ESR tantalums of the same value. At higher loads, the ceramics offer a slightly lower  $V_{\text{OUT}}$  ripple magnitude than the tantalums of the same value. However, the  $dv/dt$  of the  $V_{\text{OUT}}$  ripple with the ceramics and polymer electrolytics is much lower than the tantalums under all load conditions. The tantalums are suggested for very low profile, small size applications. The ceramics and polymer electrolytics are a good choice for low ripple, low noise applications where size is less of a concern.

#### ii) Input Capacitor ( $C_{\text{IN}}$ )

The input capacitor  $C_{\text{IN}}$  directly affects the magnitude of the input ripple voltage, and to a lesser degree the  $V_{\text{OUT}}$  ripple. A higher value  $C_{\text{IN}}$  will give a lower  $V_{\text{IN}}$  ripple. To optimize low input and output ripple as well as size a 15  $\mu\text{F}$  polymer electrolytic, 22  $\mu\text{F}$  ceramic, or 33  $\mu\text{F}$  tantalum capacitor is recommended. This will ensure low input ripple at 200 mA load current. If lower currents will be used or higher input ripple can be tolerated then a smaller capacitor may be used to reduce the overall size of the circuit. The lower ESR ceramics and polymer electrolytics achieve a lower  $V_{\text{IN}}$  ripple than the higher ESR tantalums of the same value. Tantalums make a good choice for small size, very low profile applications. The ceramics and polymer electrolytics are a good choice for low ripple, low noise applications where size is less of a concern. The 15  $\mu\text{F}$  polymer electrolytics are physically much larger than the 33  $\mu\text{F}$  tantalums and 22  $\mu\text{F}$  ceramics.



## Filter Capacitor Selection (Continued)

### iii) $C_{FIL}$

A 1  $\mu$ F, XR7 ceramic capacitor should be connected to pin  $C_{FIL}$ . This capacitor provides the filtering needed for the internal supply rail of the LM3352.

Of the different capacitor technologies, a sample of vendors that have been verified as suitable for use with the LM3352 are shown in Table 2.

TABLE 2. Capacitor Vendor Information

	Manufacturer	Tel	Fax	Website
Ceramic	Taiyo-yuden	(408) 573-4150	(408) 573-4159	www.t-yuden.com
	AVX	(803) 448-9411	(803) 448-1943	www.avxcorp.com
Tantalum	Sprague/Vishay	(207) 324-4140	(207) 324-7223	www.vishay.com
	Nichicon	(847) 843-7500	(847) 843-2798	www.nichicon.com
Polymer Electrolytic	Cornell-Dubilier (ESRD)	(508) 996-8561	(508) 996-3830	www.cornell-dubilier.com
	Sanyo (POSCAP)	(619) 661-6322	(619) 661-1055	www.sanyovideo.com

## Maximum Available Output Current

The LM3352 cannot provide 200 mA under all  $V_{IN}$  and  $V_{OUT}$  conditions. The  $V_{OUT}$  vs  $V_{IN}$  graphs in the Typical Performance Characteristics section show the minimum  $V_{IN}$  at which the LM3352 is capable of providing different load currents while maintaining  $V_{OUT}$  regulation. Refer to the Electrical Characteristics for guaranteed conditions.

## Maximum Load Under Start-Up

Due to the LM3352's unique start-up sequence, it is not able to start up under all load conditions. Starting with 45 mA or less will allow the part to start correctly under any temperature or input voltage conditions. After the output is in regulation, any load up to the maximum as specified in the Electrical Characteristics may be applied. Using a Power On

Reset circuit, such as the LP3470, is recommended if greater start up loads are expected. Under certain conditions the LM3352 can start up with greater load currents without the use of a Power On Reset Circuit (See application note AN-1144: *Maximizing Startup Loads with the LM3352 Regulated Buck/Boost Switched Capacitor Converter*).

## Thermal Protection

During output short circuit conditions, the LM3352 will draw high currents causing a rise in the junction temperature. On-chip thermal protection circuitry disables the charge pump action once the junction temperature exceeds the thermal trip point, and re-enables the charge pump when the junction temperature falls back to a safe operating point.

## Typical Application Circuits

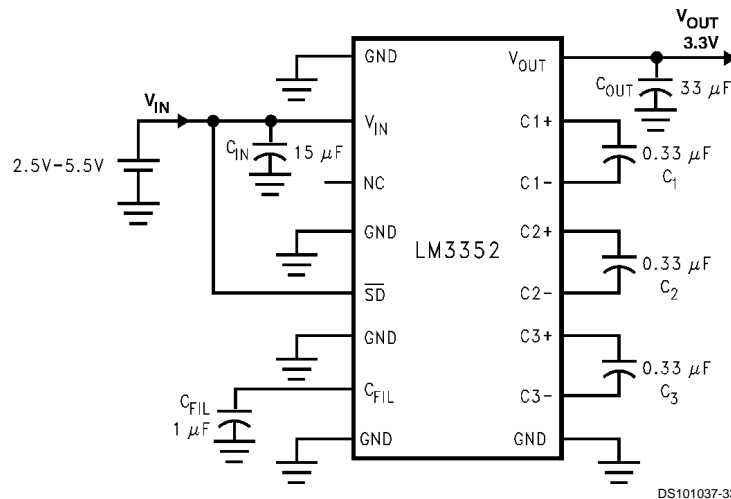
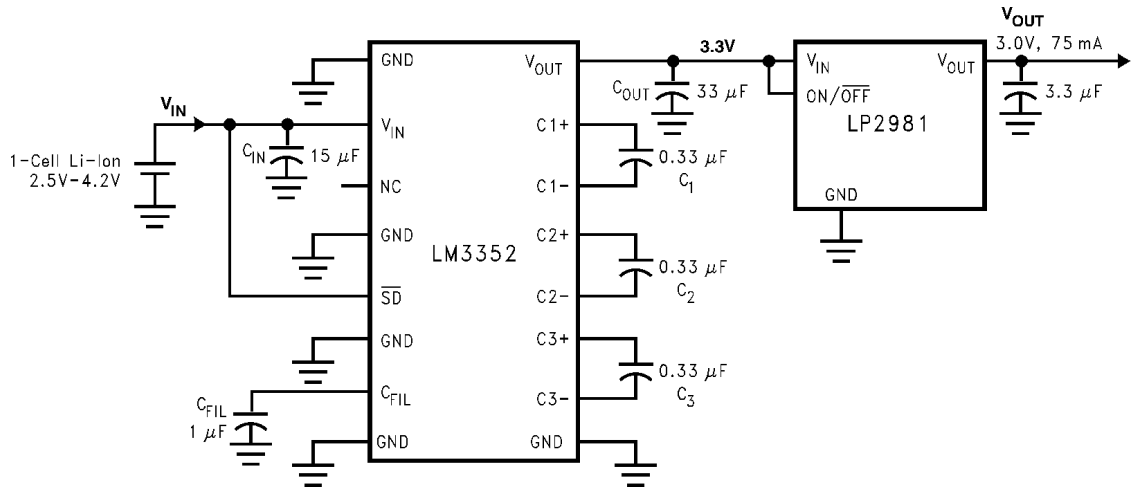

FIGURE 2. Basic Buck/Boost Regulator

Typical Application Circuits (Continued)



DS101037-15

FIGURE 3. Low Output Noise and Ripple Buck/Boost Regulator

Layout Considerations

Due to the 1 MHz typical switching frequency of the LM3352, careful board layout is a must. It is important to place the capacitors as close to the IC as possible and to keep the

traces between the capacitors and the IC short and direct. Use of a ground plane is recommended. Figure 4 shows a typical layout as used in the LM3352 evaluation board.

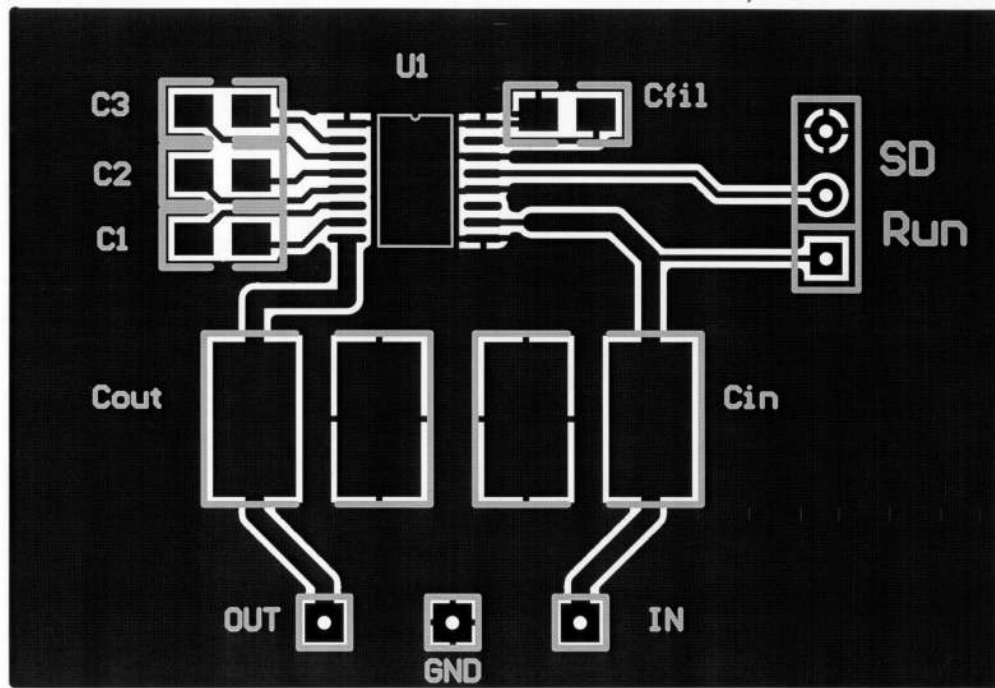

DS101037-16

FIGURE 4. Typical Layout, Top View (magnification 2.8X)

**Physical Dimensions** inches (millimeters) unless otherwise noted

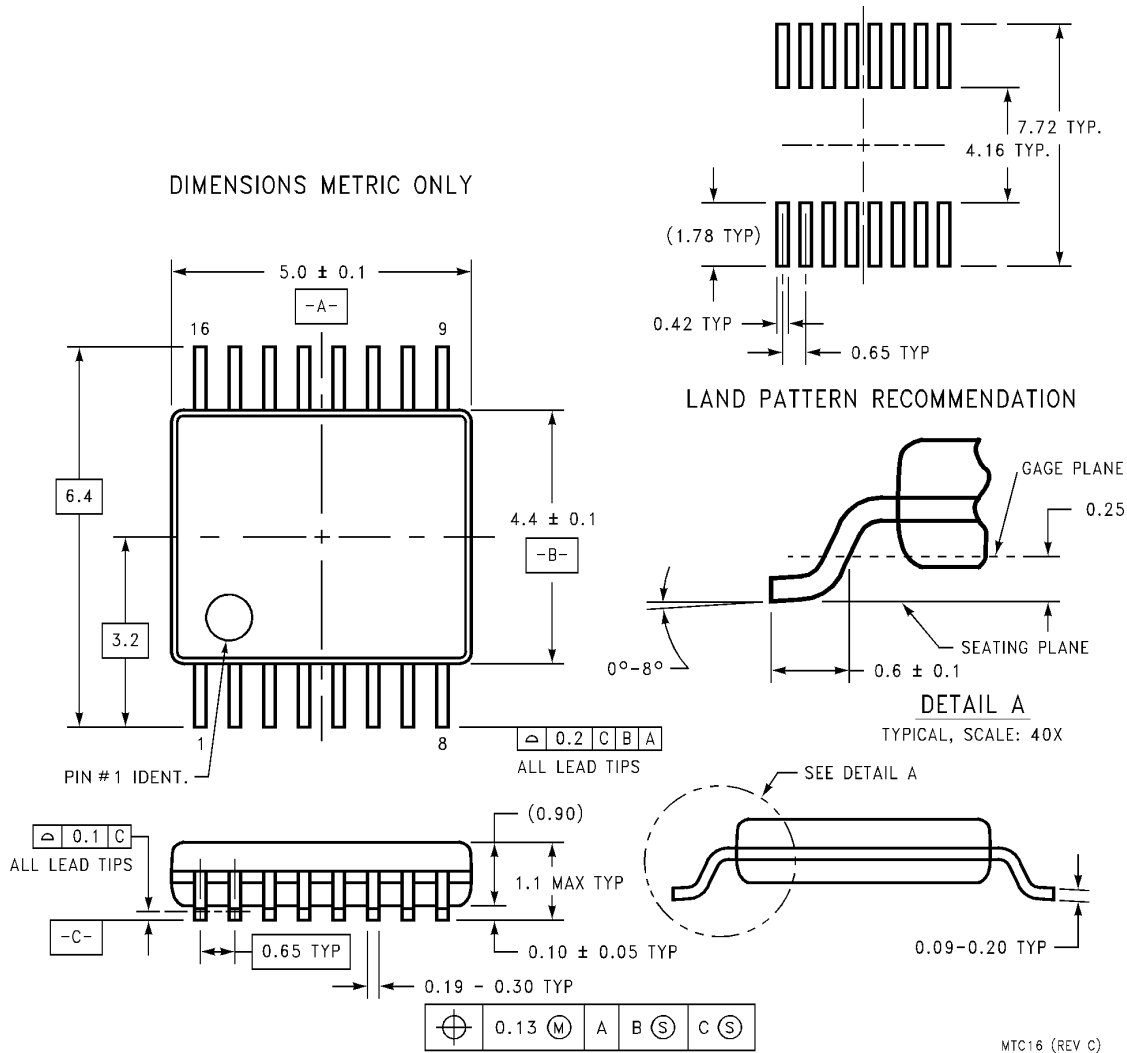

**TSSOP-16 Pin Package**  
**For Ordering, Refer to Ordering Information Table**  
**NS Package Number MTC16**

**LIFE SUPPORT POLICY**

NATIONAL'S PRODUCTS ARE NOT AUTHORIZED FOR USE AS CRITICAL COMPONENTS IN LIFE SUPPORT DEVICES OR SYSTEMS WITHOUT THE EXPRESS WRITTEN APPROVAL OF THE PRESIDENT AND GENERAL COUNSEL OF NATIONAL SEMICONDUCTOR CORPORATION. As used herein:

1. Life support devices or systems are devices or systems which, (a) are intended for surgical implant into the body, or (b) support or sustain life, and whose failure to perform when properly used in accordance with instructions for use provided in the labeling, can be reasonably expected to result in a significant injury to the user.
2. A critical component is any component of a life support device or system whose failure to perform can be reasonably expected to cause the failure of the life support device or system, or to affect its safety or effectiveness.

**National Semiconductor Corporation**  
Americas  
Email: support@nsc.com

**National Semiconductor Europe**  
Fax: +49 (0) 180-530 85 86  
Email: europe.support@nsc.com  
Deutsch Tel: +49 (0) 69 9508 6208  
English Tel: +44 (0) 870 24 0 2171  
Français Tel: +33 (0) 1 41 91 8790

**National Semiconductor Asia Pacific Customer Response Group**  
Tel: 65-2544466  
Fax: 65-2504466  
Email: ap.support@nsc.com

**National Semiconductor Japan Ltd.**  
Tel: 81-3-5639-7560  
Fax: 81-3-5639-7507

www.national.com