

PRODUCT NUMBER
95293-XXX-XXLF

RoHS COMPATIBLE, SEE NOTE 6
TOTAL NB OF POSITIONS, 3 TO 17
PACKAGING TYPE, NOTE 3

PLATING

- 1= 0.76µm GOLD/GXT ON CONTACT AREA, 2µm MATTE TIN MIN ON TAILS
- 4= 2.0µm MATTE TIN MIN FULL PLATED
- 5= 0.25µm GOLD/GXT ON CONTACT AREA, 2µm MATTE TIN MIN ON TAILS ONLY AVAILABLE UPON REQUEST
- 8= 0.38µm GOLD/GXT ON CONTACT AREA, 2µm MATTE TIN MIN ON TAILS
- 1.27µm NICKEL MIN UNDERLAYER FOR ALL PLATING VERSIONS

CATALOGUE RANGE	
PIN STYLE	MATING
01	5.84
02	8.08

APPLICATION SPECIFIC	
PIN STYLE	MATING
05	9.60
06	3.00
07	11.20
08	13.40
09	7.50

NOTES:

- 1 - HOUSING MAT'L : HIGH TEMPERATURE THERMOPLASTIC. UL94V-0 COLOR: BLACK
- 2 - PIN MATERIAL : PHOSPHOR BRONZE
- 3 - PACKAGING
 - = POLY BAGS
 - B = TUBE + CAP - ONLY AVAILABLE UPON REQUEST
 - A = TAPE & REEL + PICK-UP CAP, AS AVAILABLE
 - K = TAPE & REEL WITHOUT PICK-UP CAP, AS AVAILABLE
- 4 - 9N MIN RETENTION IN EITHER DIRECTION
- 5 - TO DETERMINE DIMENSIONS :
N = NUMBER OF POSITIONS
EXAMPLE : 8 POS N x 2.54 = 20.32mm
6. RoHS COMPATIBLE PRODUCT SPECIFICATIONS
 - a - PLATING:
 - "LF" MEANS THE PRODUCT IS LEAD-FREE, 2µm MINIMUM MATTE TIN OVER 1.27µm MINIMUM NICKEL UNDERPLATE.
 - b - MANUFACTURING PROCESS COMPATIBILITY
 - THE HOUSING WILL WITHSTAND EXPOSURE TO 260°C PEAK TEMPERATURE FOR 30 SECONDES IN A CONVECTION, INFRA-RED OR VAPOR PHASE REFLOW OVEN.
 - c - LABELING:
 - MEETS PACKAGING SPECS AS PER GS-14-920
 - d - LEGAL STATEMENT: SEE GS-47-0004

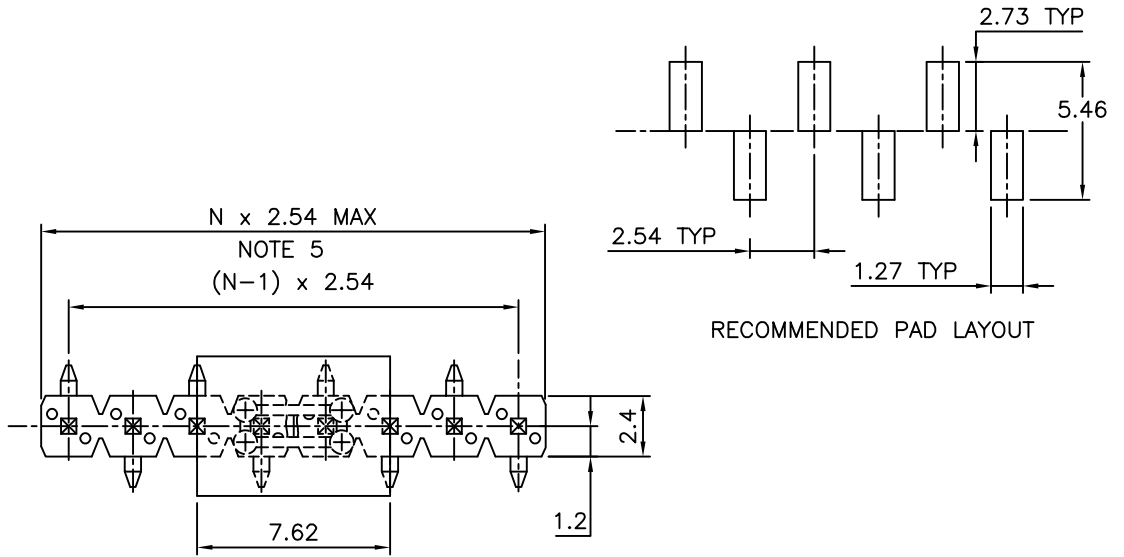

RECOMMENDED PAD LAYOUT

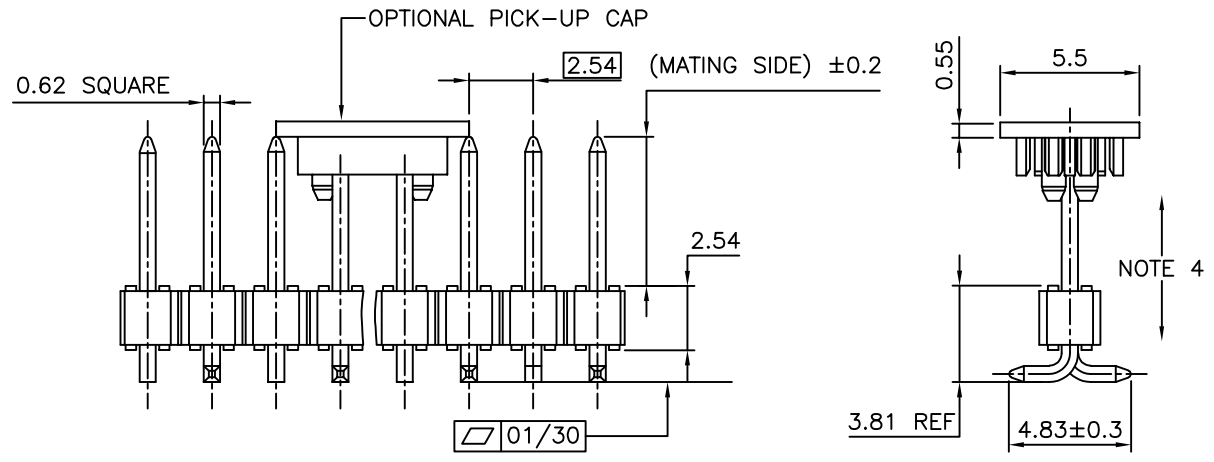

mat'l. code				surface		tolerance		projection		product family	
SEE NOTES				ISO 1302		ISO 406 ISO 1101				BERGSTIK	
ltr	ecn no	dr	date	tolerances unless otherwise specified				mm		title	
X	F-47110	DDE	23.01.25	angles	linear	x.x ±0.3	x.xx ±0.13			UNSHR.HEADER SR SMT	
				0' ±2'		x.xxx ±0.05	scale 5:1		dwg no		sheet 1 of 1
T	F-25587	LMU	16.12.08	dr	D.LE	01.01.24			95293		A3
U	F-28279	DDE	17.05.12	engr	JM.C	01.01.24			type		CUSTOMER
V	F-31174	DDE	18.09.05	chr	JM.C	01.01.24			Drawing		
W	F-35575	DDE	19.12.06	appd	JF.N	01.01.24					
sheet	revision										
index	sheet										