

REVISIONS					
REV	ECO	DESCRIPTION	DATE	BY	APPR
A1		RELEASE CUSTOMER DRAWING	30/JUN/14	JARRY	

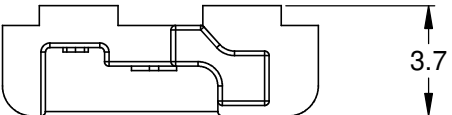
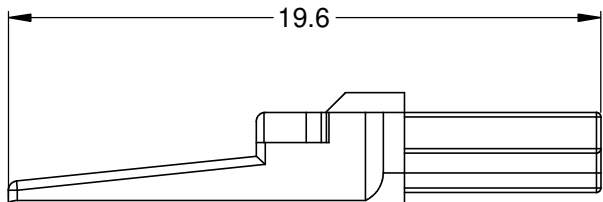
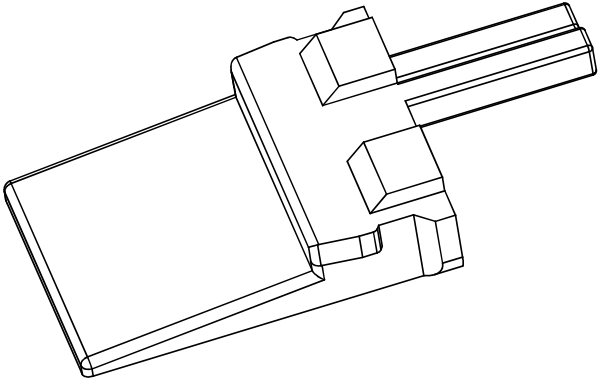
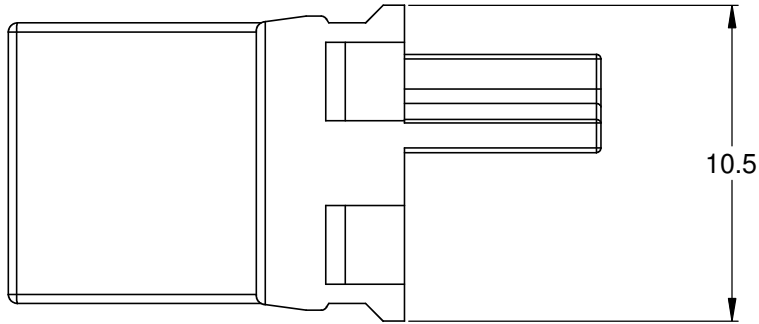

NOTES: UNLESS OTHERWISE SPECIFIED

1. MATERIAL: THERMOPLASTIC; COLOR: GREY
2. RoHS COMPLIANT
3. CAVITIES: 2
4. KEYED: KEY "A" CONFIGURATION
5. USE WITH CONNECTORS AT04-2P\*  
( \* = MODIFICATIONS AND/OR COLORS )
6. ALL DIMENSIONS ARE FOR REFERENCE USE ONLY.

AW2P-A					
QUANTITY	PART NUMBER	DESCRIPTION			ITEM
<b>MATERIALS LIST</b>					
<small>UNLESS OTHERWISE SPECIFIED</small> 1) All dimensions are in metric(mm). 2) Tolerances are as follows: 1 PL DEC ±0.30 2 PL DEC ±0.15 3 PL DEC ±0.08 Fractions ±1/64 Angles ±1° 3) Note reference =		<b>SIGNATURES</b> DRAWN: JARRY CHECKED: ENGINEER: APPROVAL: CUSTOMER:		<b>DATE</b> 30/JUN/14	
MATERIAL SPECIFICATIONS:		THIS DRAWING IS SUPPLIED FOR INFORMATION ONLY. DESIGN FEATURES, SPECIFICATIONS AND PERFORMANCE DATA SHOWN HEREON ARE THE PROPERTY OF THE AMPHENOL CORPORATION. NO RIGHTS OF REPRODUCTION ARE IMPLIED. ALL DIMENSIONS ARE SUBJECT TO NORMAL MANUFACTURING VARIATIONS.		<h1 style="margin: 0;">Amphenol</h1> <p style="margin: 0;">Sine Systems - www.amphenol-sine.com 44724 Morley Drive Clinton Township, MI 48036</p> <p style="margin: 0;"><b>P-WEDGELOCK, 2 POSITION, A KEY, AT SERIES</b></p>	
PROCESS SPECIFICATIONS:		NEXT ASSY:			
SIZE: <b>A</b>		TYPE: <b>C-</b>		DWG NO: <b>AW2P-A</b>	
SCALE: <b>NONE</b>		SHEET <b>1</b> OF <b>1</b>		REVISION: <b>A1</b>	