

FEATURES

- SFP/SFF and SFF-8472 MSA compliant
- SFP reference design available
- 50 Mbps to 4.25 Gbps operation
- Automatic average power control
- Typical 60 ps output rise/fall time
- VCSEL, DFB, and FP laser support
- Bias current range: from 2 mA to 100 mA
- Modulation current range: from 5 mA to 90 mA
- Laser fail alarm and automatic laser shutdown (ALS)
- Bias and modulation current monitoring
- Voltage setpoint control
- Resistor setpoint control
- 3.3 V supply
- 24-lead 4 mm × 4 mm LFCSP
- Pin compatible with [ADN2870](#)

APPLICATIONS

- 1×/2×/4× Fibre Channel SFP/SFF modules
- Multirate OC3 to OC48-FEC SFP/SFF modules
- LX-4 modules
- DWDM/CWDM laser transmitters
- HDTV (SMPTE family) laser transmitters

GENERAL DESCRIPTION

Like the [ADN2870](#), the [ADN2873](#) laser diode driver (LDD) is designed for advanced SFP and SFF modules, using SFF-8472 digital diagnostics. The [ADN2873](#) supports NRZ data transmission operation from 50 Mbps up to 4.25 Gbps. With a new alarm scheme, this device avoids the shutdown issue caused by the system transient generated from various lasers.

The [ADN2873](#) monitors the laser bias and modulation currents and it provides fail alarms and ALS. Using setup voltages of a microcontroller DAC or a trimmable resistor voltage divider, the [ADN2873](#) can set up a laser optical average output power and extinction ratio. The optical average power control loop consists of an optical feedback from a photodiode, the comparator, and a status holder. The [ADN2873](#) works easily with the Analog Devices, Inc., [ADuC7019/ADuC7020/ADuC7023](#) family of MicroConverter® devices and with the [ADN2890/ADN2891/ADN2892](#) family of limiting amplifiers to make a complete SFP/SFF transceiver chipset solution.

The [ADN2873](#) is pin compatible with the [ADN2870](#) dual-loop LDD, allowing the same design to work with either device. For dual-loop control applications, refer to the [ADN2870](#) data sheet.

The product is available in a space-saving 24-lead, 4 mm × 4 mm LFCSP specified over the -40°C to +85°C temperature range.

Figure 1 shows an application diagram of the voltage setpoint control with single-ended laser interface. Figure 36 shows a differential laser interface.

APPLICATIONS DIAGRAM

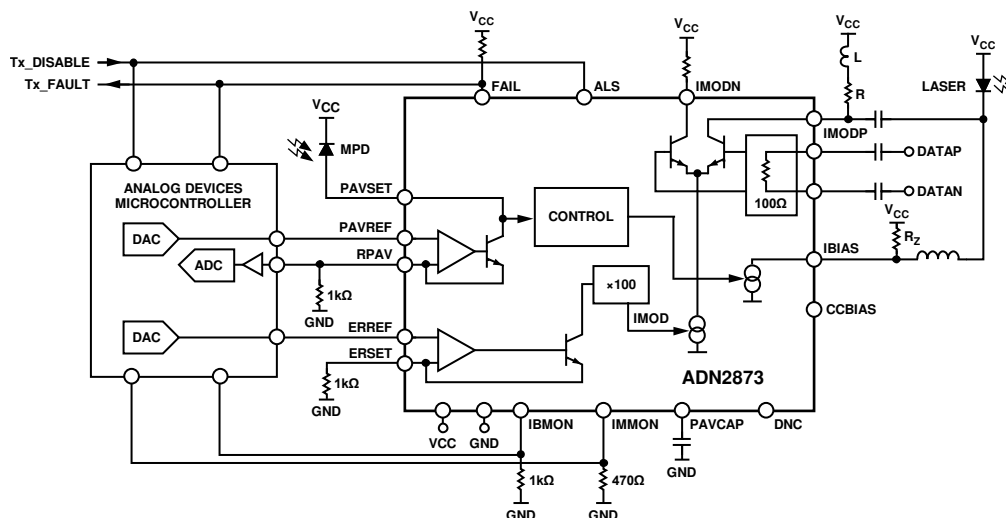

Figure 1.

07489-001

Rev. B

[Document Feedback](#)

Information furnished by Analog Devices is believed to be accurate and reliable. However, no responsibility is assumed by Analog Devices for its use, nor for any infringements of patents or other rights of third parties that may result from its use. Specifications subject to change without notice. No license is granted by implication or otherwise under any patent or patent rights of Analog Devices. Trademarks and registered trademarks are the property of their respective owners.

One Technology Way, P.O. Box 9106, Norwood, MA 02062-9106, U.S.A.
Tel: 781.329.4700 ©2008–2016 Analog Devices, Inc. All rights reserved.
[Technical Support](#) www.analog.com

TABLE OF CONTENTS

Features	1	Laser Control	13
Applications.....	1	Control Methods	13
General Description	1	Voltage Setpoint Calibration.....	13
Applications Diagram	1	Resistor Setpoint Calibration.....	15
Revision History	2	I _{MPD} Monitoring	15
Specifications.....	3	Loop Bandwidth Selection	16
SFP Timing Specifications.....	5	Power Consumption	16
Absolute Maximum Ratings.....	6	Automatic Laser Shutdown (Tx_Disable).....	16
ESD Caution.....	6	Bias and Modulation Monitor Currents.....	16
Pin Configuration and Function Descriptions.....	7	IBIAS Pin	16
Typical Performance Characteristics	8	Data Inputs.....	17
Single-Ended Output	8	Laser Diode Interfacing.....	17
Differential Output.....	9	Alarms.....	18
Performance Characteristics.....	10	Outline Dimensions	19
Optical Waveforms	12	Ordering Guide	19
Theory of Operation	13		

REVISION HISTORY

8/2016—Rev. A to Rev. B

Changes to Ordering Guide	19
---------------------------------	----

1/2016—Rev. 0 to Rev. A

Changed NC to DNC.....	Throughout
Changes to General Description Section	1
Change to Figure 6 and Table 4	7
Updated Outline Dimensions	19
Changes to Ordering Guide	19

6/2008—Revision 0: Initial Version

SPECIFICATIONS

$V_{CC} = 3.0\text{ V}$ to 3.6 V . All specifications T_{MIN} to T_{MAX}^1 , unless otherwise noted. Typical values are specified at 25°C .

Table 1.

Parameter	Min	Typ	Max	Unit	Test Conditions/Comments
LASER BIAS CURRENT (IBIAS)					
Output Current IBIAS	2		100	mA	
Compliance Voltage	1.2		V_{CC}	V	
IBIAS when ALS Is High			0.1	mA	
MODULATION CURRENT (IMODP, IMODN)²					
Output Current IMOD	5		90	mA	
Compliance Voltage	1.5		V_{CC}	V	
IMOD when ALS Is High			0.1	mA	5 mA < IMOD < 90 mA
Rise Time Single-Ended Output ^{2,3}		60	104	ps	5 mA < IMOD < 90 mA
Fall Time Single-Ended Output ^{2,3}		60	96	ps	5 mA < IMOD < 90 mA
Random Jitter Single-Ended Output ^{2,3}		0.8	1.1	ps (rms)	5 mA < IMOD < 90 mA
Deterministic Jitter Single-Ended Output ^{3,4}		19	35	ps	20 mA < IMOD < 90 mA
Pulse Width Distortion ^{2,3} Single-Ended Output		21	30	ps	20 mA < IMOD < 90 mA
Rise Time Differential Output ^{3,5}		47.1		ps	5 mA < IMOD < 30 mA
Fall Time Differential Output ^{3,5}		46		ps	5 mA < IMOD < 30 mA
Random Jitter Differential Output ^{3,5}		0.64		ps (rms)	5 mA < IMOD < 30 mA
Deterministic Jitter Differential Output ^{3,6}		12		ps	5 mA < IMOD < 30 mA
Pulse Width Distortion Differential Output ^{3,5}		2.1		ps	5 mA < IMOD < 30 mA
Rise Time Differential Output ^{3,5}		56		ps	5 mA < IMOD < 90 mA
Fall Time Differential Output ^{3,5}		55		ps	5 mA < IMOD < 90 mA
Random Jitter Differential Output ^{3,5}		0.61		ps (rms)	5 mA < IMOD < 90 mA
Deterministic Jitter Differential Output ^{3,7}		17		ps	5 mA < IMOD < 90 mA
Pulse Width Distortion Differential Output ^{3,5}		1.6		ps	5 mA < IMOD < 90 mA
AVERAGE POWER SET (PAVSET)					
Pin Capacitance			80	pF	
Voltage	1.1	1.2	1.3	V	
Photodiode Monitor Current (Average Current)	50		1200	μA	Resistor setpoint mode
EXTINCTION RATIO SET INPUT (ERSET)					
Resistance Range	1.5		25	k Ω	Resistor setpoint mode
	0.99	1	1.01	k Ω	Voltage setpoint mode
AVERAGE POWER REFERENCE VOLTAGE INPUT (PAVREF)					
Voltage Range	0.07		1	V	Voltage setpoint mode (RPAV fixed at 1 k Ω)
Photodiode Monitor Current (Average Current)	70		1000	μA	Voltage setpoint mode (RPAV fixed at 1 k Ω)
EXTINCTION RATIO REFERENCE VOLTAGE INPUT (ERREF)					
Voltage Range	0.05		0.9	V	Voltage setpoint mode (RERSET fixed at 1 k Ω)
ERREF Voltage to IMOD Gain		100		mA/V	
DATA INPUTS (DATAP, DATAN)⁸					
Input Voltage Swing (Differential)	0.4		2.4	V p-p	AC-coupled
Input Impedance (Single-Ended)		50		Ω	
LOGIC INPUTS (ALS)					
V_{IH}	2			V	
V_{IL}			0.8	V	
ALARM OUTPUT (FAIL)⁹					
V_{OFF}		>1.8		V	Voltage required at FAIL for IBIAS and IMOD to turn off when FAIL asserted
V_{ON}		<1.3		V	Voltage required at FAIL for IBIAS and IMOD to stay on when FAIL asserted

Parameter	Min	Typ	Max	Unit	Test Conditions/Comments
IBMON, IMMON DIVISION RATIO					
IBIAS/IBMON ³	76	98	112	A/A	2 mA < IBIAS < 11 mA
IBIAS/IBMON ³	85	98	115	A/A	11 mA < IBIAS < 50 mA
IBIAS/IBMON ³	92	100	108	A/A	50 mA < IBIAS < 100 mA
IBIAS/IBMON STABILITY ^{3, 10}			±5	%	10 mA < IBIAS < 100 mA
IMOD/IMMON		42		A/A	
IBMON Compliance Voltage	0		1.3	V	
SUPPLY					
I _{CC} ¹¹		31		mA	When IBIAS = IMOD = 0 mA
V _{CC} (with Respect to GND) ¹²	3.0	3.3	3.6	V	

¹ Temperature range is from -40°C to +85°C.

² Measured into a single-ended 15 Ω load (22 Ω resistor in parallel with digital scope 50 Ω input) using a 1111111100000000 pattern at 2.5 Gbps, shown in Figure 2.

³ Guaranteed by design and characterization. Not production tested.

⁴ Measured into a single-ended 15 Ω load using a K28.5 pattern at 2.5 Gbps, shown in Figure 2.

⁵ Measured into a differential 30 Ω (43 Ω differential resistor in parallel with a digital scope of 50 Ω input) load using a 1111111100000000 pattern at 4.25 Gbps, as shown in Figure 3.

⁶ Measured into a differential 30 Ω load using a K28.5 pattern at 4.25 Gbps, as shown in Figure 3.

⁷ Measured into a differential 30 Ω load using a K28.5 pattern at 2.7 Gbps, as shown in Figure 3.

⁸ When the voltage on DATAP is greater than the voltage on DATAN, the modulation current flows into the IMODP pin.

⁹ Guaranteed by design. Not production tested.

¹⁰ IBIAS/IBMON ratio stability is defined in SFF-8472 Revision 9 over temperature and supply variation.

¹¹ See the I_{CC} minimum for power calculation in the Power Consumption section.

¹² All VCC pins must be shorted together.

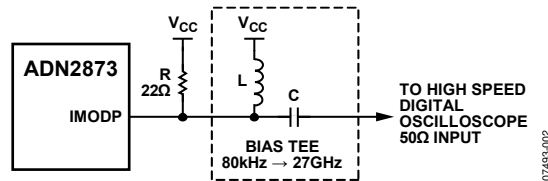

Figure 2. High Speed Electrical Test Single-Ended Output Circuit

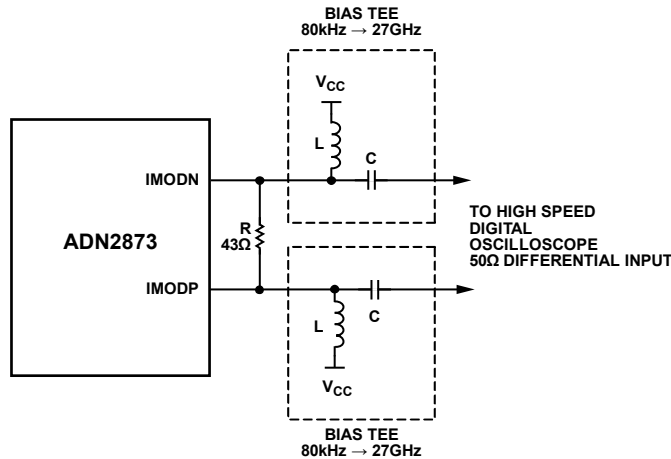

Figure 3. High Speed Electrical Test Differential Output Circuit

SFP TIMING SPECIFICATIONS

Table 2.

Parameter	Symbol	Min	Typ	Max	Unit	Test Conditions/Comments
ALS Assert Time	t_off		1	5	µs	Time for the rising edge of ALS (Tx_DISABLE) to when the bias current falls below 10% of nominal
ALS Negate Time ¹	t_on		0.15	0.4	ms	Time for the falling edge of ALS to when the modulation current rises above 90% of nominal
Time to Initialize, Including Reset of FAIL ¹	t_init		25	275	ms	From power-on or negation of FAIL using ALS
FAIL Assert Time	t_fault			100	µs	Time to fault to FAIL on
ALS to Reset Time	t_reset			5	µs	Time Tx_DISABLE must be held high to reset Tx_FAULT

¹ Guaranteed by design and characterization. Not production tested.

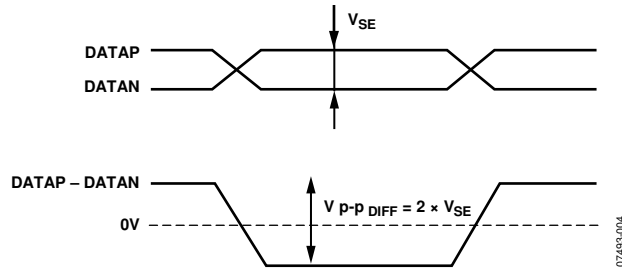

Figure 4. Signal Level Definition

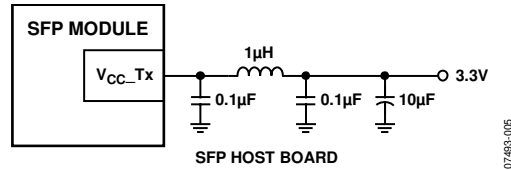

Figure 5. Recommended SFP Supply

ABSOLUTE MAXIMUM RATINGS

Table 3.

Parameter	Rating
VCC to GND	4.2V
IMODN, IMODP	-0.3V to +4.8V
All Other Pins	-0.3 to +3.9V
Junction Temperature	150°C
Operating Temperature Range, Industrial	-40°C to +85°C
Storage Temperature Range	-65°C to +150°C
Junction Temperature (T _J max)	125°C
Power Dissipation ¹	(T _J max - T _A)/θ _{JA} W
θ _{JA} Thermal Impedance ²	30°C/W
θ _{JC} Thermal Impedance	29.5°C/W
Lead Temperature (Soldering, 10 sec)	300°C

¹ Power consumption equations are provided in the Power Consumption section.

² θ_{JA} is defined when the device is soldered on a four-layer board.

Stresses at or above those listed under Absolute Maximum Ratings may cause permanent damage to the product. This is a stress rating only; functional operation of the product at these or any other conditions above those indicated in the operational section of this specification is not implied. Operation beyond the maximum operating conditions for extended periods may affect product reliability.

ESD CAUTION



ESD (electrostatic discharge) sensitive device. Charged devices and circuit boards can discharge without detection. Although this product features patented or proprietary protection circuitry, damage may occur on devices subjected to high energy ESD. Therefore, proper ESD precautions should be taken to avoid performance degradation or loss of functionality.

PIN CONFIGURATION AND FUNCTION DESCRIPTIONS

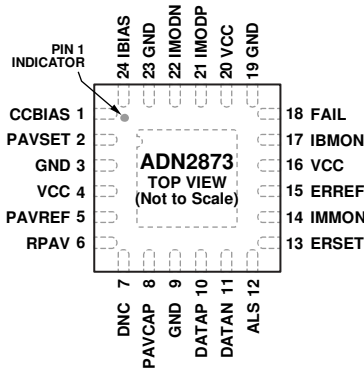

- NOTES**
 1. DNC = DO NOT CONNECT.
 2. THE LFCSP HAS AN EXPOSED PADDLE THAT MUST BE CONNECTED TO GND.

07493-006

Figure 6. Pin Configuration

Table 4. Pin Function Descriptions

Pin No.	Mnemonic	Description
1	CCBIAS	Not Used (Internally Connected to VCC)
2	PAVSET	Average Optical Power Set Pin
3	GND	Supply Ground
4	VCC	Supply Voltage
5	PAVREF	Reference Voltage Input for Average Optical Power Control
6	RPAV	Average Power Resistor when Using PAVREF
7	DNC	Do Not Connect
8	PAVCAP	Average Power Loop Capacitor
9	GND	Supply Ground
10	DATAP	Data, Positive Differential Input
11	DATAN	Data, Negative Differential Input
12	ALS	Automatic Laser Shutdown
13	ERSET	Extinction Ratio Set Pin
14	IMMON	Modulation Current Monitor Current Source
15	ERREF	Reference Voltage Input for Extinction Ratio Control
16	VCC	Supply Voltage
17	IBMON	Bias Current Monitor Current Source
18	FAIL	FAIL Alarm Output
19	GND	Supply Ground
20	VCC	Supply Voltage
21	IMODP	Modulation Current Positive Output (Current Sink), Connect to Laser Diode
22	IMODN	Modulation Current Negative Output (Current Sink)
23	GND	Supply Ground
24	IBIAS	Laser Diode Bias (Current Sink to Ground)
	EPAD	Exposed Pad. The LFCSP has an exposed paddle that must be connected to GND.

TYPICAL PERFORMANCE CHARACTERISTICS

SINGLE-ENDED OUTPUT

These performance characteristics were measured using the high speed electrical single-ended output circuit shown in Figure 2.

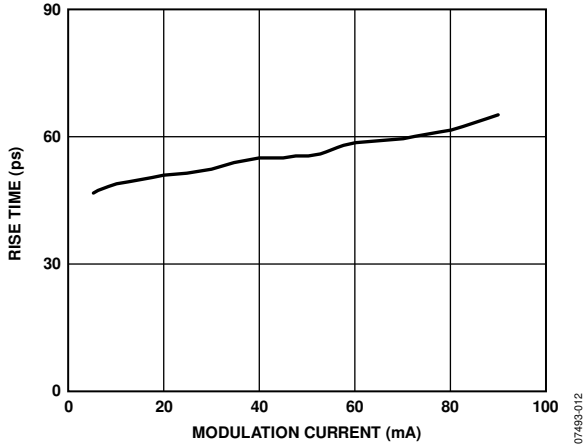

Figure 7. Rise Time vs. Modulation Current, $I_{BIAS} = 20\text{ mA}$

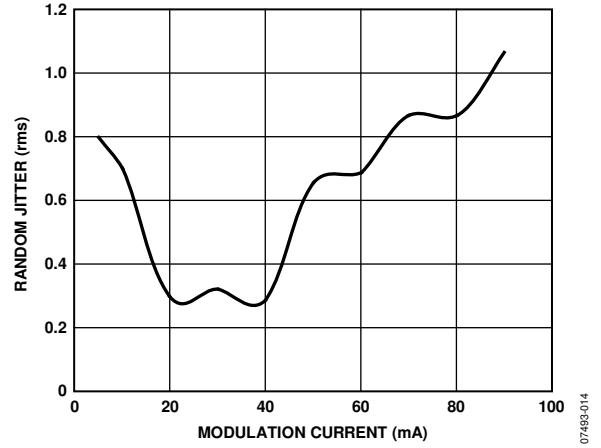

Figure 9. Random Jitter vs. Modulation Current, $I_{BIAS} = 20\text{ mA}$

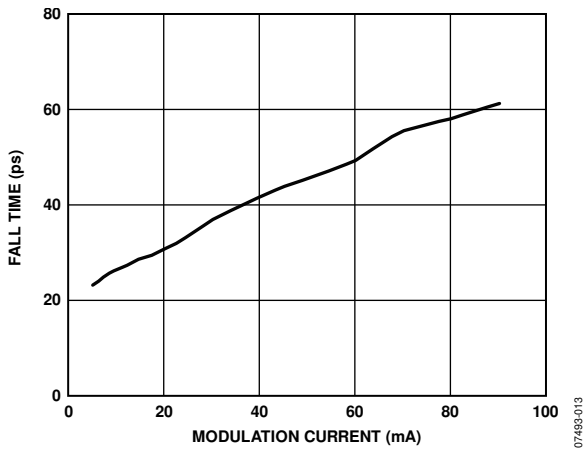

Figure 8. Fall Time vs. Modulation Current, $I_{BIAS} = 20\text{ mA}$

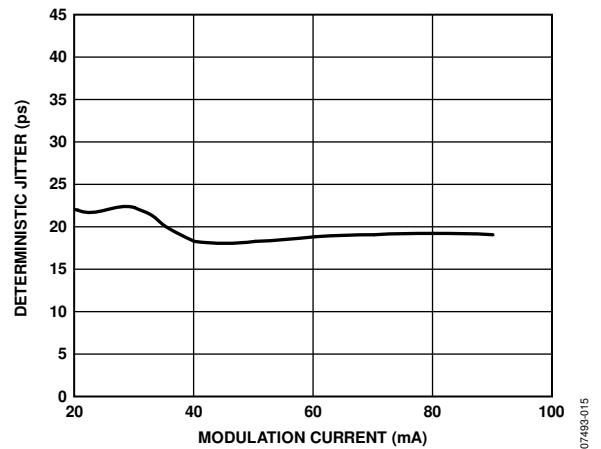

Figure 10. Deterministic Jitter at 2.488 Gbps vs. Modulation Current, $I_{BIAS} = 20\text{ mA}$

DIFFERENTIAL OUTPUT

These performance characteristics were measured using the high speed electrical differential output circuit shown in Figure 3.

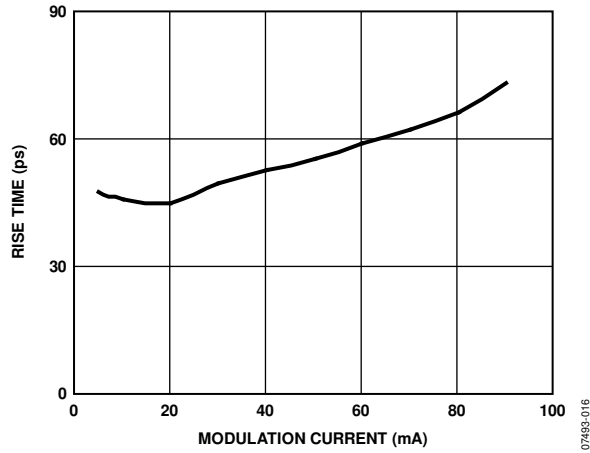

Figure 11. Rise Time vs. Modulation Current, $I_{BIAS} = 20$ mA

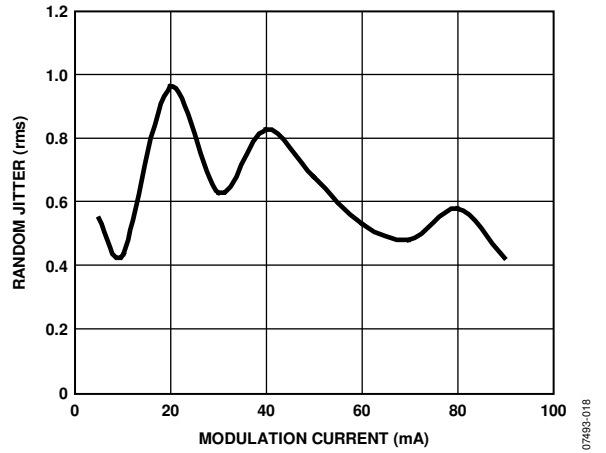

Figure 13. Random Jitter vs. Modulation Current, $I_{BIAS} = 20$ mA

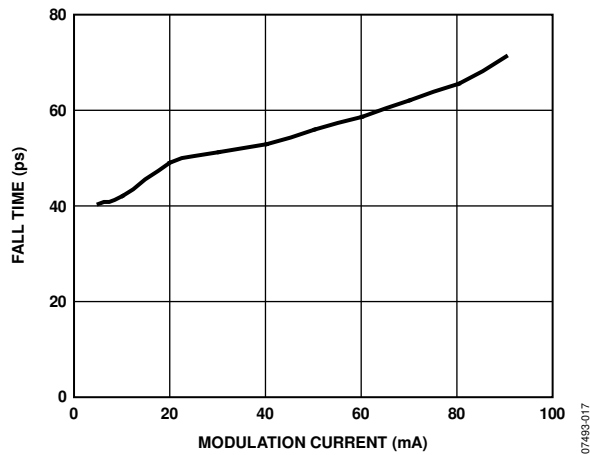

Figure 12. Fall Time vs. Modulation Current, $I_{BIAS} = 20$ mA

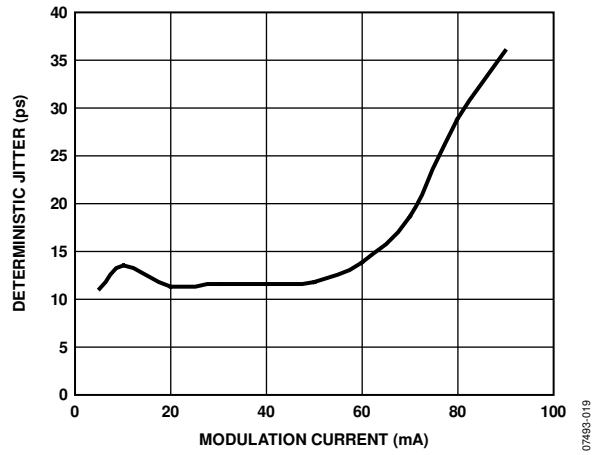

Figure 14. Deterministic Jitter at 4.25 Gbps vs. Modulation Current, $I_{BIAS} = 20$ mA

PERFORMANCE CHARACTERISTICS

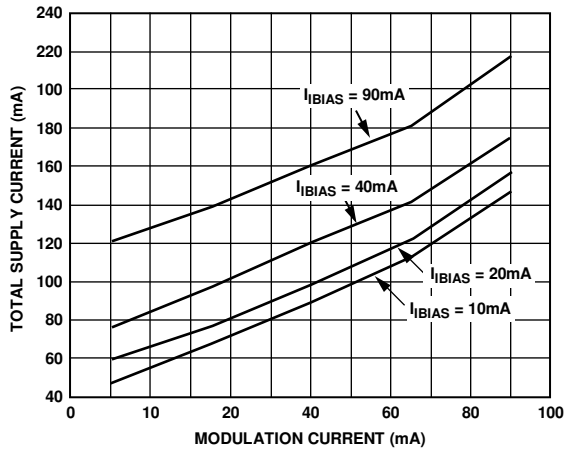

Figure 15. Total Supply Current vs. Modulation Current
 Total Supply Current = $I_{VCC} + I_{BIAS} + I_{MOD}$

07493-020

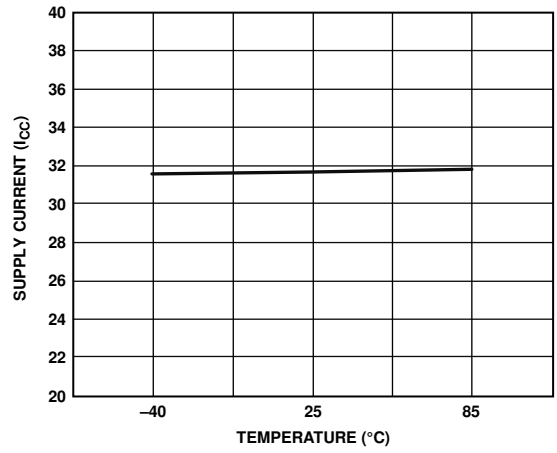

Figure 18. Supply Current (I_{CC}) vs. Temperature with ALS Asserted, $I_{BIAS} = 11\text{ mA}$

07493-023

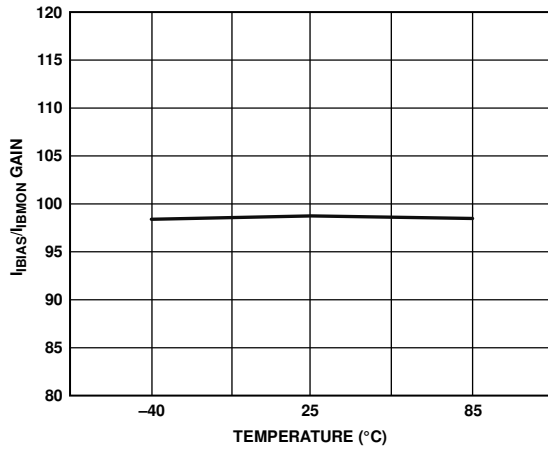

Figure 16. I_{BIAS}/I_{BMON} Gain vs. Temperature, $I_{BIAS} = 11\text{ mA}$

07493-021

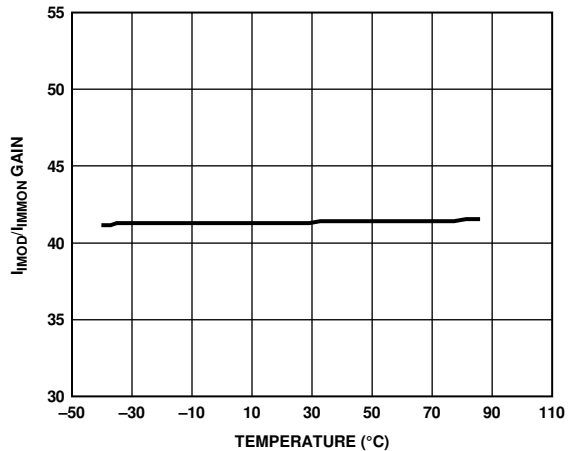

Figure 19. I_{IMOD}/I_{IMON} Gain vs. Temperature, $I_{IMOD} = 30\text{ mA}$

07493-024

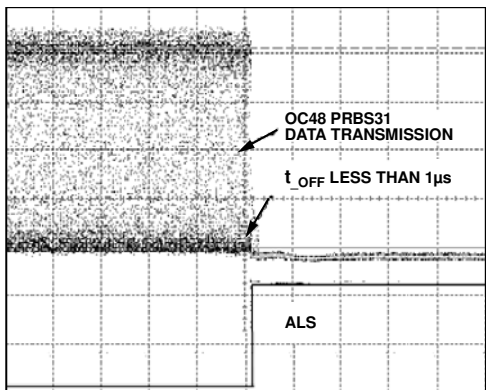

Figure 17. ALS Assert Time, 5 $\mu\text{s}/\text{DIV}$

07493-022

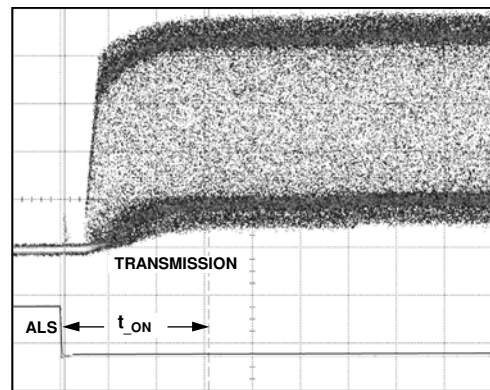
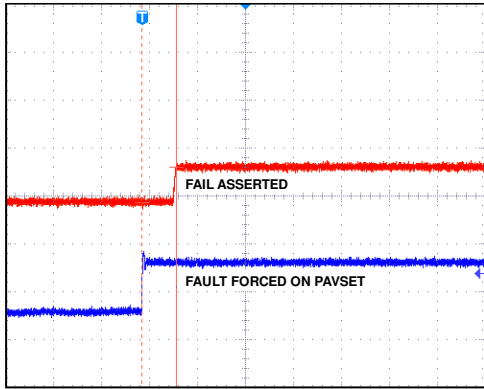

Figure 20. ALS Negate Time, 50 $\mu\text{s}/\text{DIV}$

07493-025



07493-026

Figure 21. FAIL Assert Time, 1 μ s/DIV

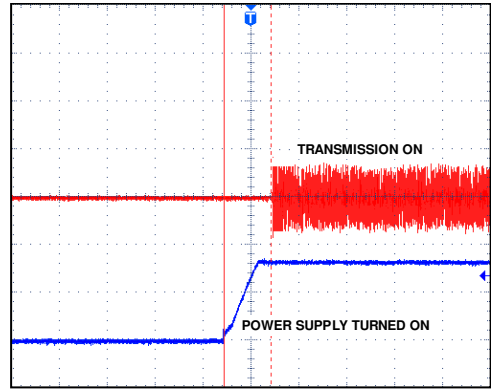

07493-027

Figure 22. Time to Initialize, Including Reset, 40 ms/DIV

OPTICAL WAVEFORMS

$V_{CC} = 3.3\text{ V}$ and $T_A = 25^\circ\text{C}$, unless otherwise noted. Note that there was no change to PAVCAP and ERCAP values when different data rates were tested. Figure 23, Figure 24, and Figure 25 show multirate performance using the low cost Fabry Perot TOSA NEC NX7315UA; Figure 26 and Figure 27 show performance over temperature using the DFB TOSA Sumitomo SLT2486.

(ACQ LIMIT TEST) WAVEFORMS 1000

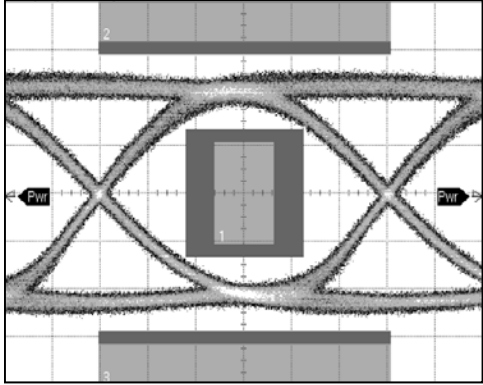

07483-007

Figure 23. Optical Eye 2.488 Gbps, 65 ps/DIV, PRBS $2^{31}-1$
 $P_{AV} = -4.5\text{ dBm}$, ER = 9 dB, Mask Margin 25%

(ACQ LIMIT TEST) WAVEFORMS 1001

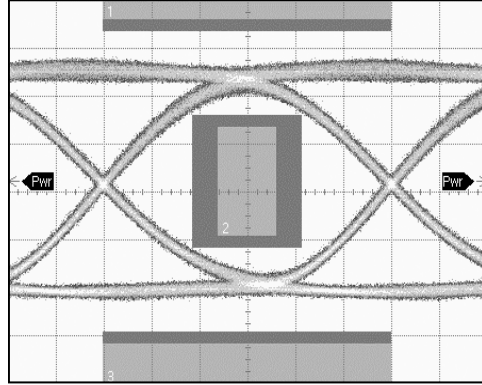

07483-010

Figure 26. Optical Eye 2.488 Gbps, 65 ps/DIV, PRBS $2^{31}-1$
 $P_{AV} = 0\text{ dBm}$, ER = 9 dB, Mask Margin 22%, $T_A = 25^\circ\text{C}$

(ACQ LIMIT TEST) WAVEFORMS 1000

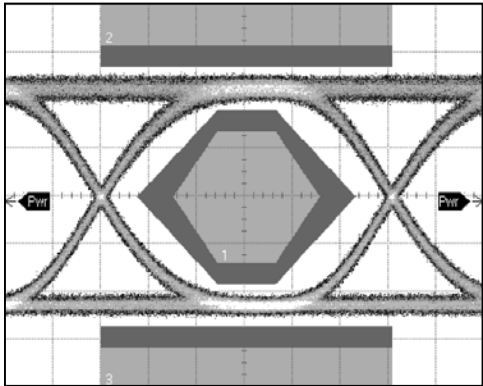

07483-008

Figure 24. Optical Eye 622 Mbps, 264 ps/DIV, PRBS $2^{31}-1$
 $P_{AV} = -4.5\text{ dBm}$, ER = 9 dB, Mask Margin 50%

(ACQ LIMIT TEST) WAVEFORMS 1001

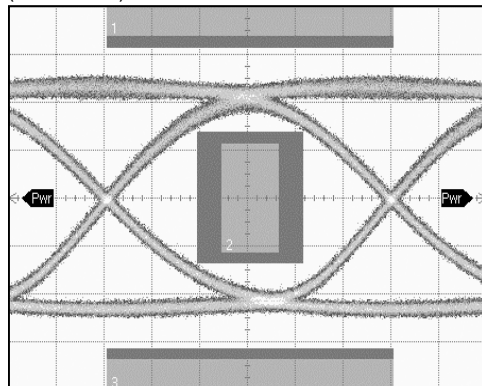

07483-011

Figure 27. Optical Eye 2.488 Gbps, 65 ps/DIV, PRBS $2^{31}-1$
 $P_{AV} = -0.2\text{ dBm}$, ER = 8.96 dB, Mask Margin 21%, $T_A = 85^\circ\text{C}$

(ACQ LIMIT TEST) WAVEFORMS 1000

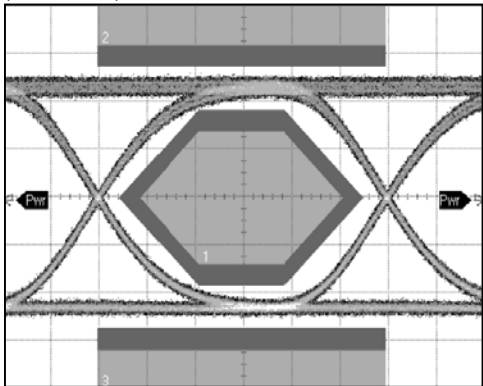

07483-009

Figure 25. Optical Eye 155 Mbps, 1.078 ns/DIV, PRBS $2^{31}-1$
 $P_{AV} = -4.5\text{ dBm}$, ER = 9 dB, Mask Margin 50%

THEORY OF OPERATION

Laser diodes have a current-in to light-out transfer function, as shown in Figure 28. Two key characteristics of this transfer function are the threshold current, I_{TH} , and the laser slope in the linear region beyond the threshold current, referred to as the slope efficiency, LI.

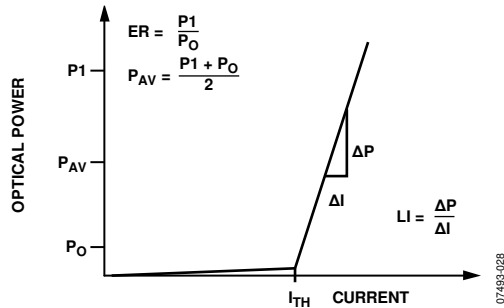

Figure 28. Laser Transfer Function

LASER CONTROL

Typically, laser threshold current and slope efficiency are both functions of temperature. For FP-type and/or DFB-type lasers, the threshold current increases and the slope efficiency decreases with increasing temperature. In addition, these parameters vary as the laser ages. To maintain a constant optical average power and a constant optical extinction ratio over temperature and laser lifetime, it is necessary to vary the applied electrical bias current and modulation current to compensate for the changing LI characteristics of the laser.

Average Power Control Loop (APCL)

The APCL compensates for changes in I_{TH} and LI by varying IBIAS. Average power control is performed by measuring the monitor photodiode (MPD) current, I_{MPD} . This current is bandwidth limited by the MPD. This is not a problem because the APCL is required to respond to the average current from the MPD.

Extinction Ratio (ER) Control

ER control is implemented by adjusting the modulation current. Temperature calibration is required to adjust the modulation current to compensate for variations of the laser characteristics with temperature.

CONTROL METHODS

The ADN2873 has two methods for setting the average power (P_{AV}) and ER. The laser optical output average power and extinction ratio are configurable by using the voltage setting or the resistor setting. In voltage setting mode, a microcontroller DAC can drive the PAVREF and ERREF pins with programmable voltages. Alternatively, in resistor setting mode, the resistor divider or potentiometers can set proper voltages at the PAVSET and ERSET pins. Refer to Figure 29 and Figure 30 for details.

VOLTAGE SETPOINT CALIBRATION

The ADN2873 allows interface to a microcontroller for both control and monitoring (see Figure 29). The average power and extinction ratio can be set using the microcontroller DACs to provide controlled reference voltages, PAVREF and ERREF.

$$PAVREF = P_{AV} \times R_{SP} \times R_{PAV} \quad (V)$$

$$ERREF = \frac{I_{MOD} \times R_{ERSET}}{100} \quad (V)$$

where:

P_{AV} is the laser optical average power output required.

R_{SP} is the optical responsivity (in amperes per watt).

$R_{PAV} = R_{ERSET} = 1 \text{ k}\Omega$.

I_{MOD} is the modulation current.

In voltage setpoint mode, R_{PAV} and R_{ERSET} must be 1 k Ω resistors with a 1% tolerance and a temperature coefficient of 50 ppm/ $^{\circ}\text{C}$.

Power-On Sequence in Voltage Setpoint Mode

During power-up, an initial sequence allows 25 ms before enabling the alarms. Therefore, the user must ensure that the voltages applied to PAVREF and ERREF are stabilized within 20 ms after ramp-up of the power supply. If supplying the PAVREF and ERREF voltages after the 25 ms, the alarms and FAIL circuitry kick in before the voltages are stabilized to PAVREF and ERREF, which causes an unexpected failure.

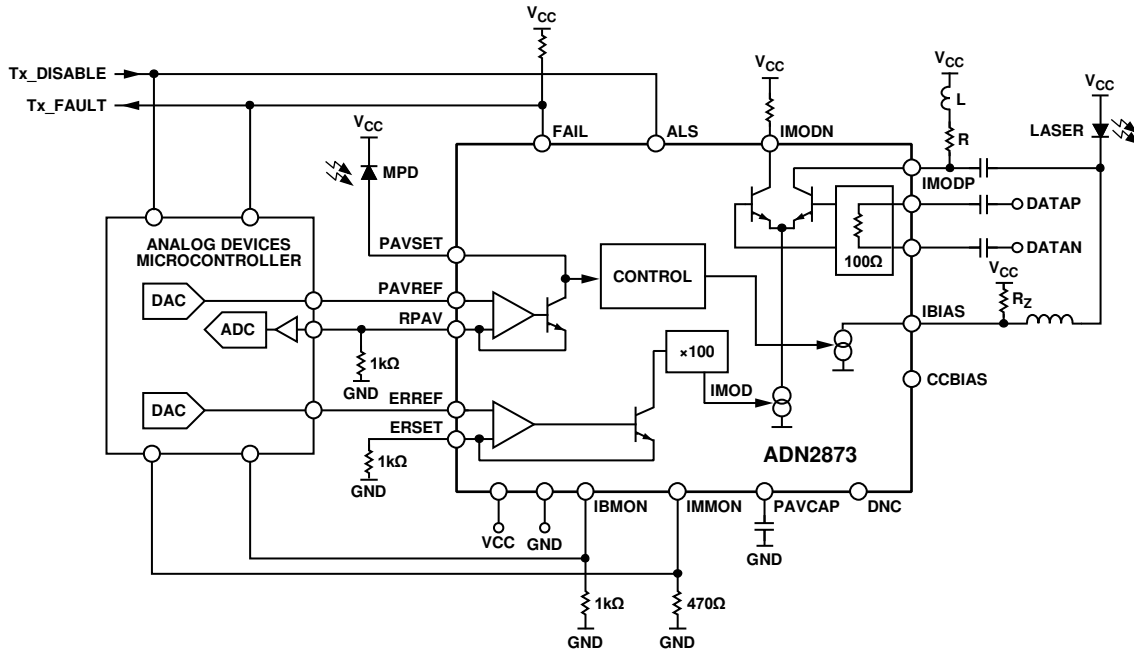

Figure 29. Using Microconverter Voltage Setpoint Calibration and Monitoring

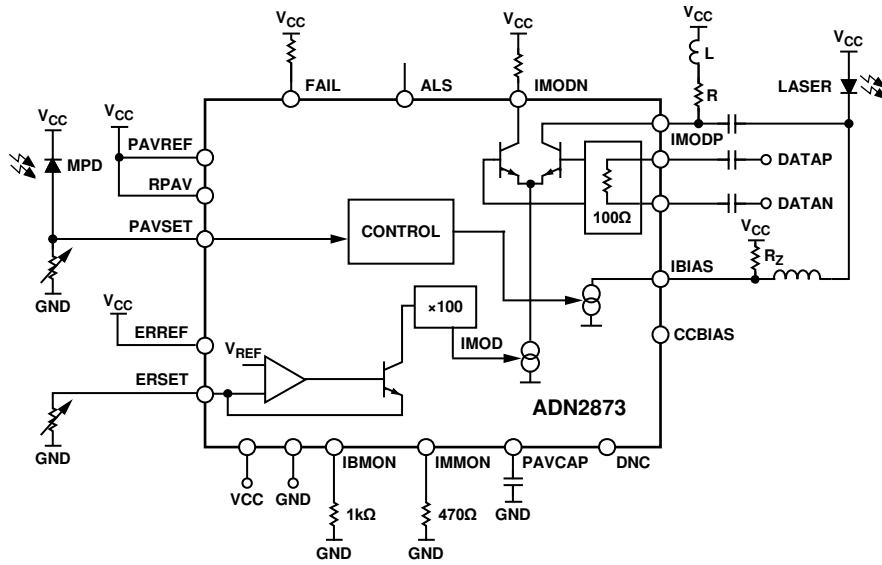

Figure 30. Using Resistor Setpoint Calibration of Average Power and Extinction Ratio

07495-029

07495-030

RESISTOR SETPOINT CALIBRATION

In resistor setpoint calibration, the PAVREF, ERREF, and RPAV pins must all be tied to VCC. The average power and extinction ratio can be set using the PAVSET and ERSET pins, respectively. A resistor is placed between the pin and GND to set the current flowing in each pin, as shown in Figure 30. The ADN2873 ensures that both PAVSET and ERSET are kept 1.23 V above GND. The PAVSET and ERSET resistors are given by

$$R_{PAVSET} = \frac{1.2 \text{ V}}{P_{AV} \times R_{SP}} \quad (\text{k}\Omega)$$

$$R_{ERSET} = \frac{1.2 \text{ V} \times 100}{I_{MOD}} \quad (\text{k}\Omega)$$

where:

P_{AV} is the average power required (mW). R_{SP} is the optical responsivity (in mA/mW).

I_{MOD} is the modulation current required (mA).

Power-On Sequence in Resistor Setpoint Mode

Note that during power-up, the ADN2873 starts an initial process sequence that allows 25 ms before enabling the device alarms. The resistors connected to the PAVSET and ERSET pins must be stable within 20 ms after turning on the power supply. The ADN2873 alarm may kick in and assert FAIL, provided the PAVSET and ERSET resistors are stabilized 20 ms after turning on the power supply.

I_{MPD} MONITORING

I_{MPD} monitoring can be implemented for voltage setpoint and resistor setpoint as described in the following sections.

Voltage Setpoint

In voltage setpoint calibration, two methods can be used for I_{MPD} monitoring: measuring voltage at RPAV and measuring I_{MPD} across a sense resistor.

Method 1: Measuring Voltage at RPAV

The I_{MPD} current is equal to the voltage at RPAV divided by the value of RPAV (see Figure 31) as long as the laser is on and is being controlled by the control loop. This method does not provide a valid I_{MPD} reading when the laser is in shutdown or fail mode. A microconverter-buffered ADC input can be connected to RPAV to make this measurement. No decoupling or filter capacitors must be placed on the RPAV node because this can disturb the control loop.

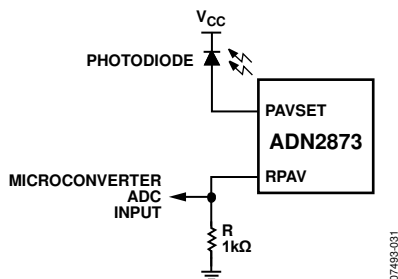

Figure 31. Single Measurement of I_{MPD} at RPAV in Voltage Setpoint Mode

Method 2: Measuring I_{MPD} Across a Sense Resistor

The second method has the advantage of providing a valid I_{MPD} reading at all times but has the disadvantage of requiring a differential measurement across a sense resistor directly in series with the I_{MPD} . As shown in Figure 32, a small resistor, R_x , is placed in series with the I_{MPD} . If the laser used in the design has a pinout where the monitor photodiode cathode and the lasers anode are not connected, a sense resistor, R_x , can be placed in series with the photodiode cathode and V_{CC} , as shown in Figure 33. When choosing the value of the resistor, the user must take into account the expected I_{MPD} value in normal operation. The resistor must be large enough to make a significant signal for the buffered ADC to read, but small enough not to cause a significant voltage reduction across the photodiode. The voltage across the sense resistor must not exceed 250 mV when the laser is in normal operation. It is recommended that a 10 pF capacitor be placed in parallel with the sense resistor.

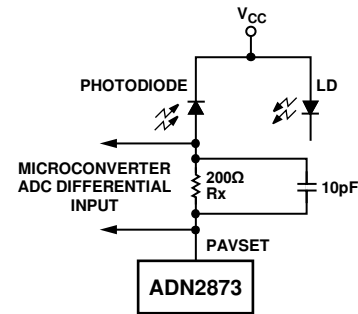

Figure 32. Differential Measurement of I_{MPD} Across a Sense Resistor

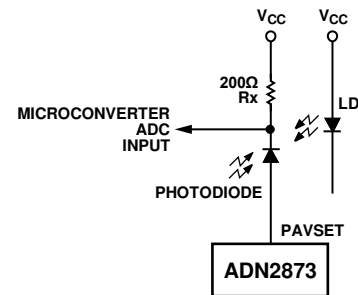

Figure 33. Single Measurement of I_{MPD} Across a Sense Resistor

Resistor Setpoint

In resistor setpoint calibration, the current through the resistor from PAVSET to GND is the I_{MPD} current. The recommended method for measuring the I_{MPD} current is to place a small resistor in series with the PAVSET resistor (or potentiometer) and measure the voltage across this resistor, as shown in Figure 34. The I_{MPD} current is then equal to this voltage divided by the value of resistor used. In resistor setpoint calibration, PAVSET is held to 1.2 V nominal; it is recommended that the sense resistor be selected so that the voltage across the sense resistor does not exceed 250 mV.

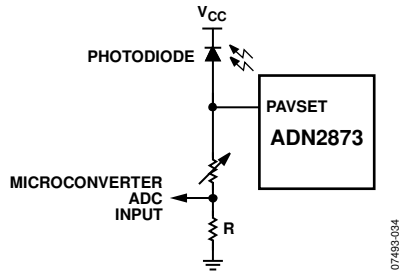

Figure 34. Recommended Method of I_{MPD} Measurement Across a Sense Resistor in Resistor Setting Mode

LOOP BANDWIDTH SELECTION

To ensure that the ADN2873 control loop has sufficient bandwidth, the average power loop capacitor (PAVCAP) is calculated using the slope efficiency of the laser (watts/amps) and the average power required.

For resistor setpoint control,

$$PAVCAP = 3.2 \times 10^{-6} \times \frac{LI}{P_{AV}} \quad (\text{Farad})$$

For voltage setpoint control,

$$PAVCAP = 1.28 \times 10^{-6} \times \frac{LI}{P_{AV}} \quad (\text{Farad})$$

where:

LI is the typical slope efficiency at 25°C of a batch of lasers that
 P_{AV} is the average power required (mW).
 are used in a design (mW/mA).

LI can be calculated as

$$LI = \frac{P1 - P0}{I_{MOD}} \quad (\text{mW/mA})$$

where:

$P1$ is the optical power (mW) at the one level.
 $P0$ is the optical power (mW) at the zero level.

The capacitor value equation obtains a centered value for the particular type of laser that is used in a design and an average power setting. The laser LI can vary by a factor of 7 between different physical lasers of the same type and across temperatures without the need to recalculate the PAVCAP value.

This capacitor is placed between the PAVCAP pin and ground. It is important that the capacitor is a low leakage, multilayer ceramic type with an insulation resistance greater than 100 GΩ or a time constant of 1000 sec, whichever is less. Pick a standard off-the-shelf capacitor value such that the actual capacitance is within ±30% of the calculated value after the tolerance of the capacitor is taken into account.

POWER CONSUMPTION

The ADN2873 die temperature must be kept below 125°C. The LFCSP has an exposed paddle, which must be connected so that it is at the same potential as the ADN2873 GND pins.

Power consumption can be calculated as

$$I_{CC} = I_{CC \text{ min}} + 0.3 I_{MOD}$$

$$P = V_{CC} \times I_{CC} + (I_{BIAS} \times V_{BIAS_PIN}) + I_{MOD} (V_{MODP_PIN} + V_{MODN_PIN})/2$$

$$T_{DIE} = T_{AMBIENT} + \theta_{JA} \times P$$

Thus, the maximum combination of $I_{BIAS} + I_{MOD}$ must be calculated, where:

$I_{CC \text{ min}} = 32$ mA, the typical value of I_{CC} provided in Table 1 with $I_{BIAS} = I_{MOD} = 0$.

T_{DIE} is the die temperature.

V_{BIAS_PIN} is the voltage at the IBIAS pin.

V_{MODP_PIN} is the voltage at the IMODP pin.

V_{MODN_PIN} is the voltage at the IMODN pin.

$T_{AMBIENT}$ is the ambient temperature.

AUTOMATIC LASER SHUTDOWN (Tx_DISABLE)

ALS (Tx_DISABLE) is an input that shuts down the optical output of the transmitter. The ALS pin is pulled up internally with a 6 kΩ resistor and conforms to SFP MSA specifications. When ALS is logic high or when open, both the bias and modulation currents are turned off. If an alarm has been triggered and the bias and modulation currents are turned off, ALS can be brought high and then low to clear the alarm.

BIAS AND MODULATION MONITOR CURRENTS

IBMON and IMMON are current-controlled current sources that mirror a ratio of the bias and modulation current. The monitor bias current, IBMON, and the monitor modulation current, IMMON, if both are connected to ground through a resistor to provide a voltage proportional to the bias current and modulation current, respectively. When using a microcontroller, the voltage developed across these resistors can be connected to two of the ADC channels, making a digital representation of the bias and modulation current available.

IBIAS PIN

The ADN2873 IBIAS pin has one on-chip, 800 Ω pull-up resistor. The current sink from this resistor is V_{IBIAS} dependent.

$$I_{UP} = \frac{V_{CC} - V_{IBIAS}}{0.8} \quad (\text{mA})$$

where V_{IBIAS} is the voltage measured at the IBIAS pin after setup of one laser bias current, I_{BIAS} .

Usually, when set up, a maximum laser bias current of 100 mA results in a V_{IBIAS} to about 1.2 V. In a worst-case scenario, $V_{CC} = 3.6$ V, $V_{IBIAS} = 1.2$ V, and I_{UP} (the current bypass through the 800 Ω resistor) ≤ 3 mA.

This on-chip resistor damps out the low frequency oscillation observed from some inexpensive lasers. If the on-chip resistance does not provide enough damping, one external R_Z (see Figure 35) may be necessary.

DATA INPUTS

Data inputs must be ac-coupled (10 nF capacitors are recommended) and are terminated via a 100 Ω internal resistor between the DATAP and DATAN pins. A high impedance circuit sets the common-mode voltage and is designed to allow maximum input voltage headroom over temperature. It is necessary to use ac-coupling to eliminate the need for matching the common-mode voltages of the data source and the ADN2873 data input pins.

LASER DIODE INTERFACING

Figure 35 shows the recommended circuit for interfacing the ADN2873 to most TO-can or coax lasers. Uncooled DFB and FP lasers typically have impedances of 5 Ω to 7 Ω and have axial leads. The circuit shown works over the full range of data rates from 155 Mbps to 3.3 Gbps, including multirate operation (without changes to PAVCAP and ERCAP values); see Figure 23, Figure 24, and Figure 25 for multirate performance examples. Coax lasers have special characteristics that make them difficult to interface to. They tend to have higher inductance and their impedance is not well controlled. The circuit in Figure 35 operates by deliberately miterminating the transmission line at the laser side while providing a very high quality matching network at the driver side.

The impedance of the driver side matching network is very flat in the designed frequency range and enables multirate operation. A series damping resistor must not be used.

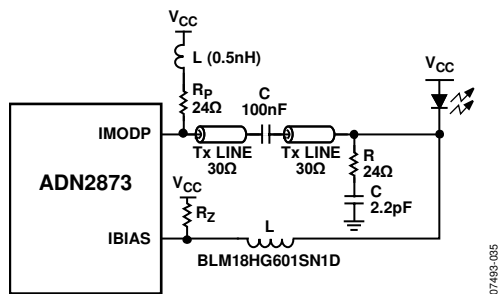

Figure 35. Recommended Interface for ADN2873 AC Coupling

The 30 Ω transmission line used is a compromise between the drive current required and the total power consumed.

Other transmission line values can be used, with some modification of the component values. In Figure 35, the R and C snubber values 24 Ω and 2.2 pF, respectively, represent a starting point and must be tuned for the particular model of laser being used. Rp, the pull-up resistor, is in series with a very small (0.5 nH) inductor. In some cases, an inductor is not required or can be accommodated with deliberate parasitic inductance, such as a thin trace or a via placed on the PC board.

Care must be taken to mount the laser as close as possible to the PC board, minimizing the exposed lead length between the laser can and the edge of the board. The axial lead of a coax laser is very inductive (approximately 1 nH per mm). Long exposed leads result in slower edge rates and reduced eye margin.

Recommended component layouts and Gerber files are available by contacting sales at Analog Devices. Note that the circuit in Figure 35 can supply up to 56 mA of modulation current to the laser, sufficient for most lasers available today. Higher currents can be accommodated by changing transmission lines and back-match values; contact sales for recommendations. This interface circuit is not recommended for butterfly-style lasers or other lasers with 25 Ω characteristic impedance. Instead, a 25 Ω transmission line and inductive (instead of resistive) pull-up is recommended. The ADN2873 single-ended application shown in Figure 35 is recommended for use up to 2.7 Gbps. From 2.7 Gbps to 4.25 Gbps, a differential drive is recommended when driving VCSELs or lasers that have slow fall times. Differential drive can be implemented by adding a few extra components. A possible implementation is shown in Figure 36. The bias and modulation currents that are programmed into the ADN2873 need to be larger than the bias and modulation current required at the laser due to the laser ac coupling interface and because some modulation current flows in the pull-up resistors, R1 and R2.

In Figure 35 and Figure 36, Resistor RZ is required to achieve optimum eye quality. The recommended RZ value is approximately 500 Ω ~ 800 Ω.

The interface circuit needs a special modification to support HDTV pathological test patterns. Contact sales at Analog Devices for HDTV support.

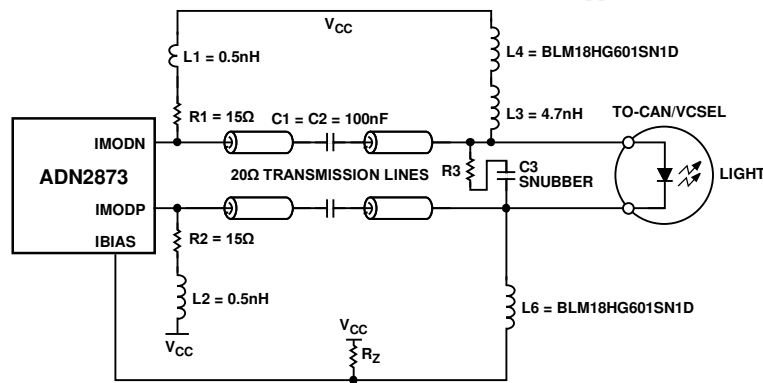

SNUBBER SETTINGS: 40Ω AND 1.5pF, NOT OPTIMIZED, OPTIMIZATION SHOULD CONSIDER THE PARASITIC OF THE INTERFACE CIRCUITRY.

Figure 36. Recommended Differential Drive Circuit

ALARMS

The ADN2873 has a latched, active high monitoring alarm (FAIL). The FAIL alarm output is open drain in conformance with SFP MSA specification requirements.

The ADN2873 has a three-fold alarm system that covers

- Use of a bias current that is higher than expected, likely as a result of laser aging
- Out-of-bounds average voltage at the monitor photodiode (MPD) input, indicating an excessive amount of laser power or a broken loop
- Undervoltage in the IBIAS node (laser diode cathode) that increases the laser power

The bias current alarm trip point is set by selecting the value of resistor on the IBMON pin to GND. The alarm is triggered when the voltage on the IBMON pin goes above 1.2 V. FAIL is

activated when the single-point alarms in Table 5 occur. The circuit in Figure 37 can indicate that FAIL has been activated while allowing the bias and modulation currents to remain on. The V_{BE} of the transistor clamps the FAIL voltage to below 1.3 V, disabling the automatic shutdown of bias and modulation currents. If an alarm has triggered and FAIL is activated, ALS can be brought high and then low to clear the alarm.

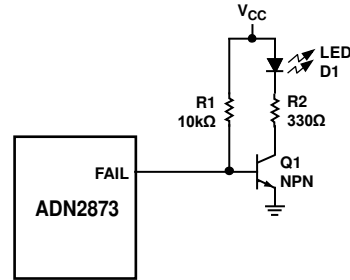

Figure 37. FAIL Indication Circuit

Table 5. ADN2873 Single-Point Alarms

Alarm Type	Mnemonic	Overtoltage or Short to V_{CC} Condition	Undervoltage or Short to GND Condition
Bias Current	IBMON	Alarm if >1.2 V typical ($\pm 10\%$ tolerance)	Ignore
MPD Current	PAVSET	Alarm if >2.0 V	Alarm if <0.4 V
Crucial Nodes	ERRREF (the ERRREF designed is tied to V_{CC} in resistor setting mode)	Alarm if shorted to V_{CC} (the alarm is valid for voltage setting mode only)	Ignore
	IBIAS	Ignore	Alarm if shorted to GND

Table 6. ADN2873 Response to Various Single-Point Faults in AC-Coupled Configuration (as shown in Figure 35 and Figure 36)

Pin	Short to V_{CC}	Short to GND	Open
PAVSET	Fault state occurs	Fault state occurs	Fault state occurs
PAVREF	Voltage mode: fault state occurs Resistor mode: tied to V_{CC}	Fault state occurs	Fault state occurs Circuit designed to tie to V_{CC} in resistor setting mode, so no open case
RPAV	Voltage mode: fault state occurs Resistor mode: tied to V_{CC}	Fault state occurs	Voltage mode: fault state occurs Resistor mode: does not increase average power
PAVCAP	Fault state occurs	Fault state occurs	Fault state occurs
DATAP	Does not increase laser average power	Does not increase laser average power	Does not increase laser average power
DATAN	Does not increase laser average power	Does not increase laser average power	Does not increase laser average power
ALS	Output currents shut off	Normal currents	Output currents shut off
ERSET	Does not increase laser average power	Does not increase laser average power	Does not increase laser average power
IMMON	Does not affect laser power	Does not increase laser average power	Does not increase laser average power
ERRREF	Voltage mode: fault state occurs Resistor mode: tied to V_{CC}	Voltage mode: does not increase average power Resistor mode: fault state occurs	Does not increase laser average power
IBMON	Fault state occurs	Does not increase laser average power	Does not increase laser average power
FAIL	Fault state occurs	Does not increase laser average power	Does not increase laser average power
IMODP	Does not increase laser average power	Does not increase laser average power	Does not increase laser average power
IMODN	Does not increase laser average power	Does not increase laser average power	Does not increase laser power
IBIAS	Fault state occurs	Fault state occurs	Fault state occurs

OUTLINE DIMENSIONS

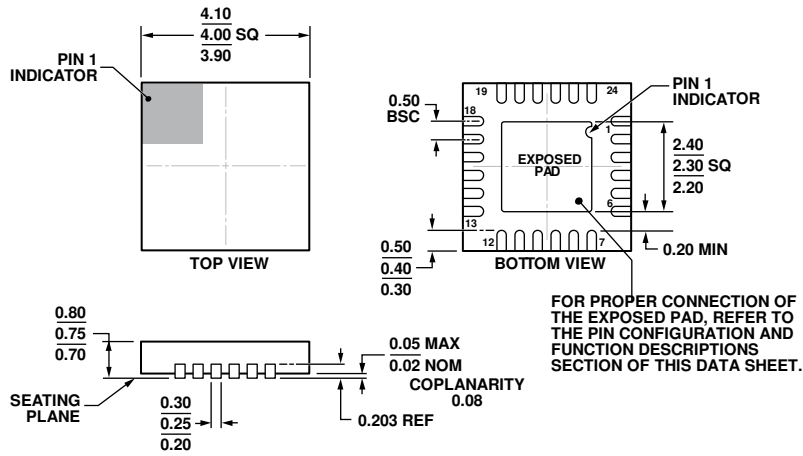

COMPLIANT TO JEDEC STANDARDS MO-220-WGGD-8.

Figure 38. 24-Lead Lead Frame Chip Scale Package [LFCS]
 4 mm × 4 mm Body and 0.75 mm Package Height
 (CP-24-14)
 Dimensions shown in millimeters

01-18-2012-A

ORDERING GUIDE

Model ¹	Temperature Range	Package Description	Package Option
ADN2873ACPZ	-40°C to +85°C	24-Lead Lead Frame Chip Scale Package [LFCS]	CP-24-14
ADN2873ACPZ-R7	-40°C to +85°C	24-Lead Lead Frame Chip Scale Package [LFCS], 7" Tape and Reel	CP-24-14

¹ Z = RoHS Compliant Part.

NOTES