

LOC		DIST		REVISIONS			
DF	DO	REV	DESCRIPTION	DATE	BY	APPV	
		K	REV PER ECO-06-005876	10APR06	TK	CT	

- .040 DIA HOLE IS RECOMMENDED FOR P.C. BOARD.
- CONNECTOR MATES WITH ANY AMP 26 POSN RECEPTACLE.
- REPLACEMENT PIN AMP# 207683-8.
- UL/CSA DESIGNATION STAMPED IN THIS AREA.
- CLINCH NUT (2 EA) IS USED ON 208867-2 ONLY.
- CADMIUM PER QQ-P-416.
- FINISH: ZINC PER ASTM-B-633 .000200-.000400 THK WITH SUPPLEMENTARY CHROMATE (Cr3+).

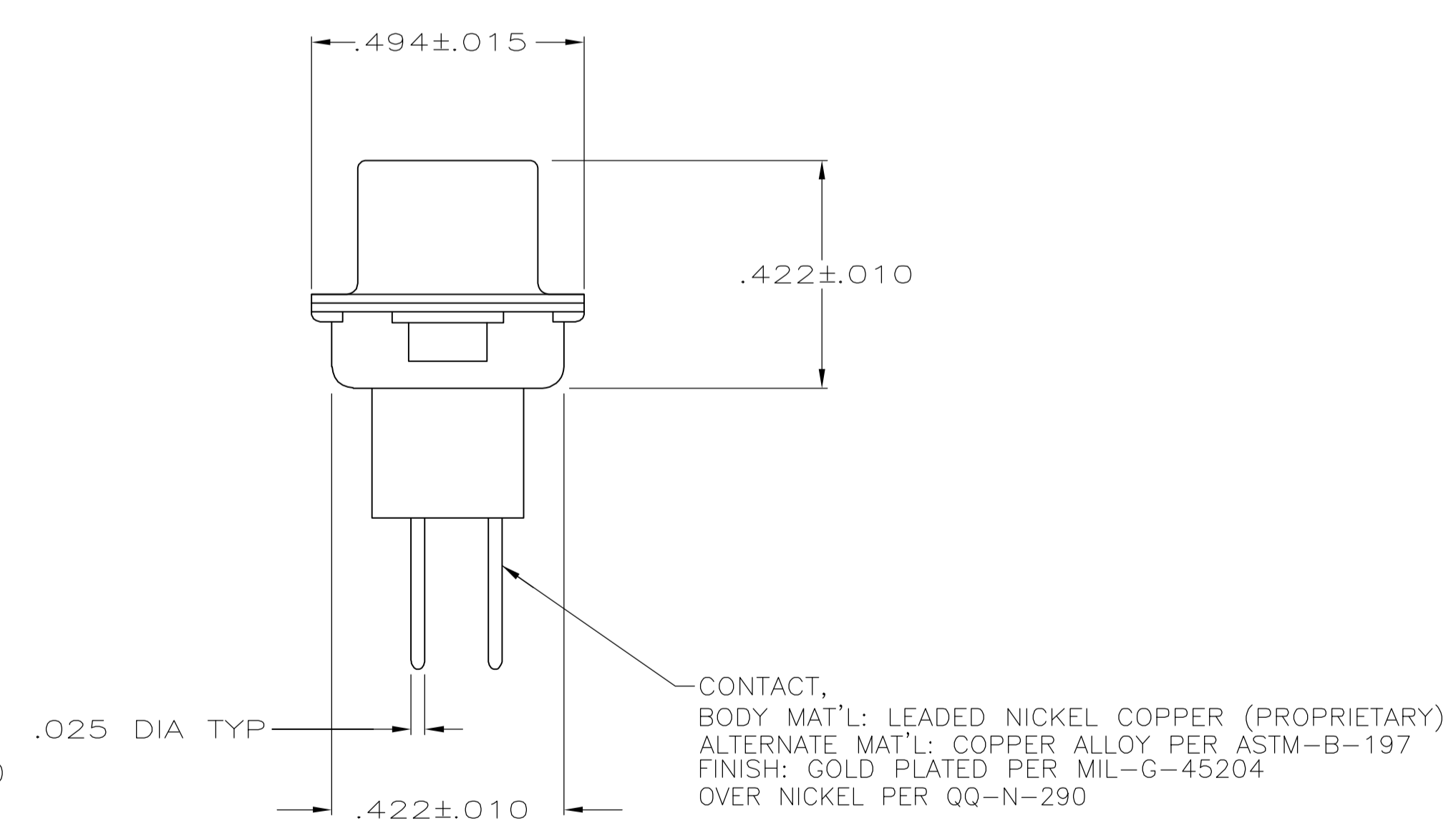
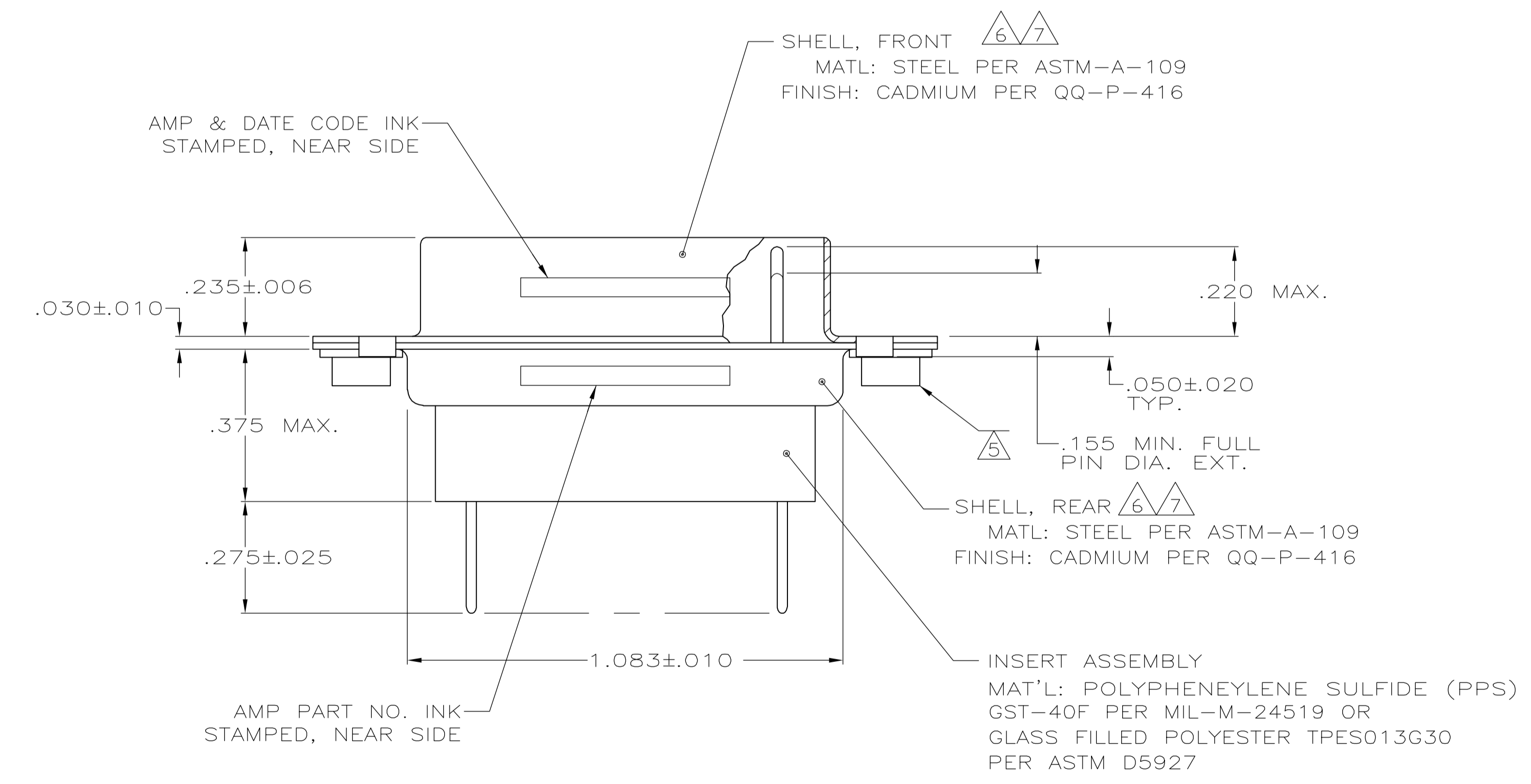
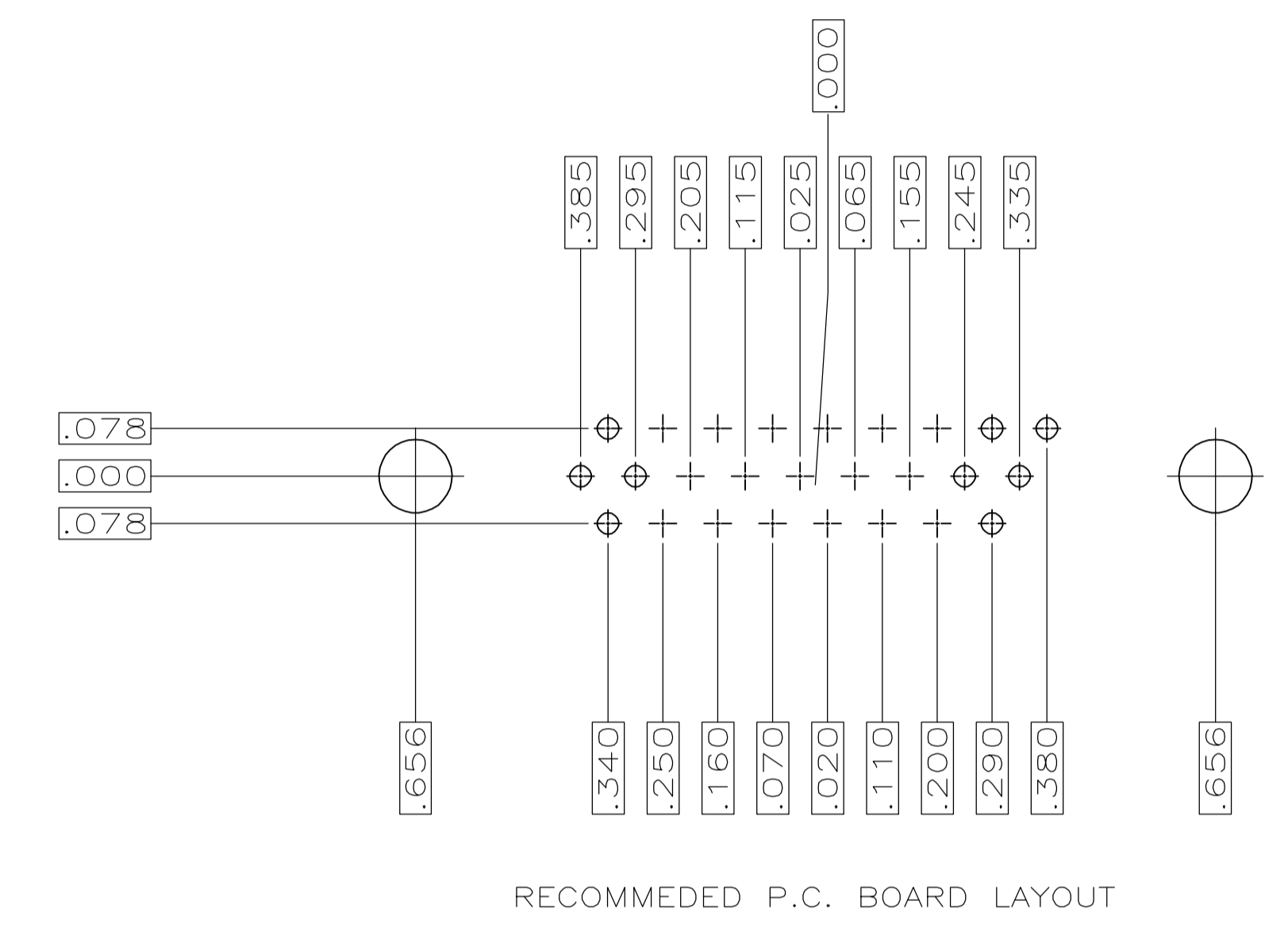
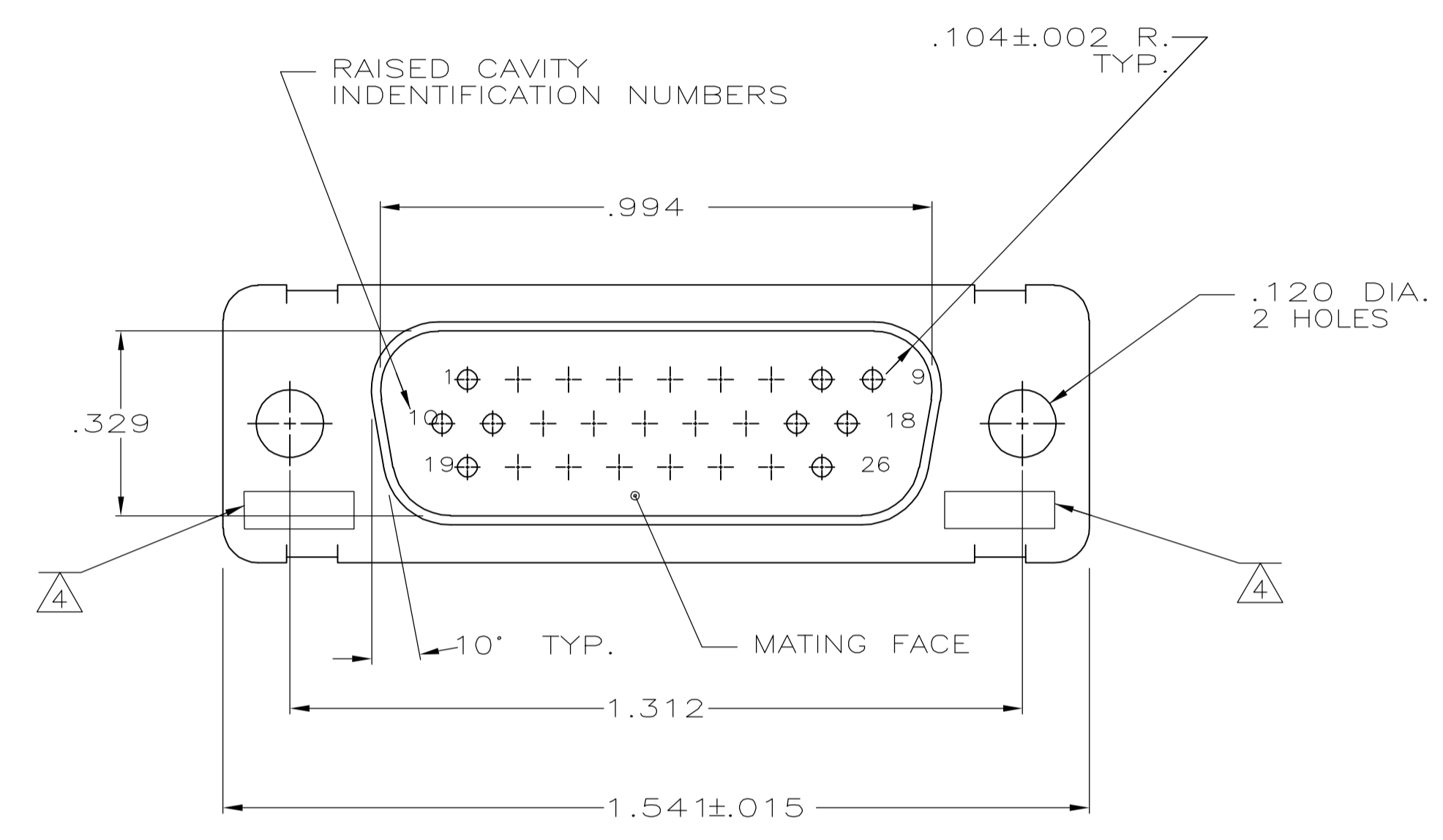

7	5-208867-1
6 5	208867-2
6	208867-1
REMARKS	PART NO

THIS DRAWING IS A CONTROLLED DOCUMENT.

DIMENSIONS: INCHES	TOLERANCES UNLESS OTHERWISE SPECIFIED:	DIN C.C.THOMAS 1-7-88	1-26-88		Tyco Electronics Corporation Harrisburg, PA 17105-3608	
0 PLC ± -	1 PLC ± -	2 PLC ± -	3 PLC ± .005		4 PLC ± -	ANGLES ± -
MATERIAL SEE CALLOUTS	FINISH SEE CALLOUTS	WEIGHT	SIZE	CAGE CODE	DRAWING NO	RESTRICTED TO
			A1	00779	208867	
CUSTOMER DRAWING			SCALE	4:1	SHEET	1 OF 1
			REV	K		