



ICPL2530, ICPL2531

DESCRIPTION

The ICPL2530 and ICPL2531 dual channel devices each consists of an infrared emitting diode optically coupled to a high speed photo detector transistor. A separate connection for the photodiode bias and output transistor collector increases the speed by several orders of magnitude over conventional phototransistor couplers by reducing the base-collector capacitance.

FEATURES

- High Speed 1Mbit/s
- High AC Isolation Voltage 5000V_{RMS}
- Guaranteed Performance from 0°C to 70°C
- Wide Operating Temperature Range -40°C to 100 °C
- Pb Free and RoHS Compliant
- Safety Approvals Pending

APPLICATIONS

- Line Receivers
- Telecommunication Equipment
- Power Transistor Isolation in Motor Drives
- Replacement of Low Speed Phototransistor Optocouplers
- High Speed Logic Ground Isolation

ORDER INFORMATION

- Add G after PN for 10mm lead spacing
- Add SM after PN for Surface Mount
- Add SMT&R after PN for Surface Mount Tape & Reel

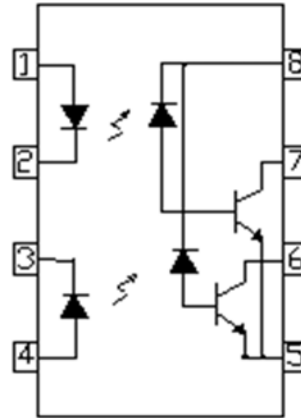

1. Anode
2. Cathode
3. Cathode
4. Anode
5. Gnd
6. Vout2
7. Vout1
8. Vcc

ABSOLUTE MAXIMUM RATINGS

Input Diode

Forward Current	25mA
Peak Forward Current (50% duty cycle 1ms pulse width)	50mA
Peak Transient Current (≤ 1μs pulse width, 300pps)	1A
Reverse Voltage	5V
Power dissipation	45mW

Output

Average Output Current	8mA
Peak Output Current	16mA
Output Voltage	-0.5 to 20V
Supply Voltage	-0.5 to 30V
Power Dissipation	35mW

Total Package

Isolation Voltage	5000V _{RMS}
Operating Temperature	-40 to 100 °C
Storage Temperature	-55 to 125 °C
Lead Soldering Temperature (10s)	260°C

ISOCOM COMPONENTS 2004 LTD

Unit 25B, Park View Road West, Park View Industrial Estate
Hartlepool, Cleveland, TS25 1UD, United Kingdom
Tel: +44 (0)1429 863 609 Fax : +44 (0)1429 863 581
e-mail: sales@isocom.co.uk
<http://www.isocom.com>

ISOCOM COMPONENTS ASIA LTD

Hong Kong Office,
Block A, 8/F, Wah Hing Industrial mansion,
36 Tai Yau Street, San Po Kong, Kowloon, Hong Kong.
Tel: +852 2995 9217 Fax : +852 8161 6292
e-mail sales@isocom.com.hk



ICPL2530, ICPL2531

ELECTRICAL CHARACTERISTICS

INPUT ($T_A = 0^\circ\text{C}$ to 70°C unless otherwise specified)

Parameter	Symbol	Test Condition	Min	Typ.*	Max	Unit
Forward Voltage	V_F	$I_F = 16\text{mA}$, $T_A = 25^\circ\text{C}$		1.45	1.8	V
Reverse Voltage	V_R	$I_R = 10\mu\text{A}$	5.0			V
Temperature Coefficient	V_F/T_A	$I_F = 16\text{mA}$		-1.9		mV/ $^\circ\text{C}$
Input Capacitance	C_{IN}	$V_F = 0\text{V}$, $f = 1\text{MHz}$		60		pF

OUTPUT ($T_A = 0^\circ\text{C}$ to 70°C unless otherwise specified)

Parameter	Symbol	Test Condition	Min	Typ.*	Max	Unit
Logic High Output Current	I_{OH}	$I_F = 0\text{mA}$, $V_O = V_{CC} = 5.5\text{V}$, $T_A = 25^\circ\text{C}$		0.001	0.5	μA
		$I_F = 0\text{mA}$, $V_O = V_{CC} = 15\text{V}$, $T_A = 25^\circ\text{C}$			50	
Logic Low Supply Current	I_{CCL}	$I_{F1} = I_{F2} = 16\text{mA}$, $V_O = \text{Open}$, $V_{CC} = 15\text{V}$		140	400	μA
Logic High Supply Current	I_{CCH}	$I_F = 0\text{mA}$, $V_O = \text{Open}$ $V_{CC} = 15\text{V}$, $T_A = 25^\circ\text{C}$		0.01	1	μA
		$I_F = 0\text{mA}$, $V_O = \text{Open}$ $V_{CC} = 15\text{V}$			4	

* Typical Values at $T_A = 25^\circ\text{C}$



ICPL2530, ICPL2531

ELECTRICAL CHARACTERISTICS

COUPLED ($T_A = 0^\circ\text{C}$ to 70°C unless otherwise specified)

Parameter	Symbol	Test Condition	Min	Typ.*	Max	Unit
Current Transfer Ratio	CTR	ICPL2530 ICPL2531 $I_F = 16\text{mA}$, $V_O = 0.4\text{V}$ $V_{CC} = 4.5\text{V}$, $T_A = 25^\circ\text{C}$	7 19		50 50	%
		ICPL2530 ICPL2531 $I_F = 16\text{mA}$, $V_O = 0.5\text{V}$ $V_{CC} = 4.5\text{V}$	5 15			%
Logic Low Output Voltage	V_{OL}	ICPL2530 $I_F = 16\text{mA}$, $I_O = 1.1\text{mA}$ $V_{CC} = 4.5\text{V}$, $T_A = 25^\circ\text{C}$		0.18	0.5	V
		ICPL2531 $I_F = 16\text{mA}$, $I_O = 3\text{mA}$ $V_{CC} = 4.5\text{V}$, $T_A = 25^\circ\text{C}$		0.25	0.5	V
		ICPL2530 $I_F = 16\text{mA}$, $I_O = 0.8\text{mA}$ $V_{CC} = 4.5\text{V}$			0.5	V
		ICPL2531 $I_F = 16\text{mA}$, $I_O = 2.4\text{mA}$ $V_{CC} = 4.5\text{V}$			0.5	V

* Typical Values at $T_A = 25^\circ\text{C}$



ICPL2530, ICPL2531

ELECTRICAL CHARACTERISTICS

Switching Characteristics

($T_A = 0^\circ\text{C}$ to 70°C , $V_{CC} = 5\text{V}$, $I_F = 16\text{mA}$ unless otherwise specified)

Parameter	Symbol	Test Condition	Min	Typ.*	Max	Unit
Propagation Delay Time to Logic Low	t_{PHL}	ICPL2530 $R_L = 4.1\text{k}\Omega$, $T_A = 25^\circ\text{C}$ $R_L = 4.1\text{k}\Omega$		0.35	1.5 2.0	μs
		ICPL2531 $R_L = 1.9\text{k}\Omega$, $T_A = 25^\circ\text{C}$ $R_L = 1.9\text{k}\Omega$		0.35	0.8 1.0	
Propagation Delay Time to Logic High	t_{PLH}	ICPL2530 $R_L = 4.1\text{k}\Omega$, $T_A = 25^\circ\text{C}$ $R_L = 4.1\text{k}\Omega$		0.5	1.5 2.0	μs
		ICPL2531 $R_L = 1.9\text{k}\Omega$, $T_A = 25^\circ\text{C}$ $R_L = 1.9\text{k}\Omega$		0.3	0.8 1.0	
Common Mode Transient Immunity at Logic High	CM_H	ICPL2530 $I_F = 0\text{mA}$, $V_{CM} = 10\text{Vp-p}$, $R_L = 4.1\text{k}\Omega$, $T_A = 25^\circ\text{C}$	1000	10000		$\text{V}/\mu\text{s}$
		ICPL2531 $I_F = 0\text{mA}$, $V_{CM} = 1000\text{Vp-p}$, $R_L = 1.9\text{k}\Omega$, $T_A = 25^\circ\text{C}$	1000	10000		$\text{V}/\mu\text{s}$
Common Mode Transient Immunity at Logic Low	CM_L	ICPL2530 $I_F = 16\text{mA}$, $V_{CM} = 10\text{Vp-p}$, $R_L = 4.1\text{k}\Omega$, $T_A = 25^\circ\text{C}$	1000	10000		$\text{V}/\mu\text{s}$
		ICPL2531 $I_F = 16\text{mA}$, $V_{CM} = 1000\text{Vp-p}$, $R_L = 1.9\text{k}\Omega$, $T_A = 25^\circ\text{C}$	1000	10000		$\text{V}/\mu\text{s}$

* Typical Values at $T_A = 25^\circ\text{C}$

- Common mode transient immunity in logic high level is the maximum tolerable (positive) dV_{CM}/dt on the leading edge of the common mode pulse signal V_{CM} , to assure that the output will remain in a logic high state (i.e. $V_O > 2.0\text{V}$).
- Common mode transient immunity in logic low level is the maximum tolerable (negative) dV_{CM}/dt on the trailing edge of the common mode pulse signal, V_{CM} , to assure that the output will remain in a logic low state (i.e. $V_O < 0.8\text{V}$).



ICPL2530, ICPL2531

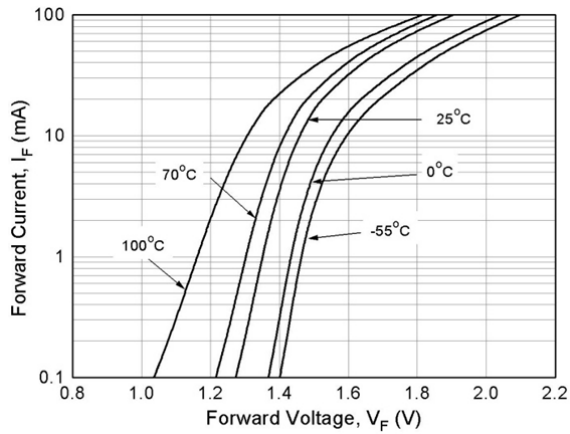

Fig 1 Forward Current vs Forward Voltage

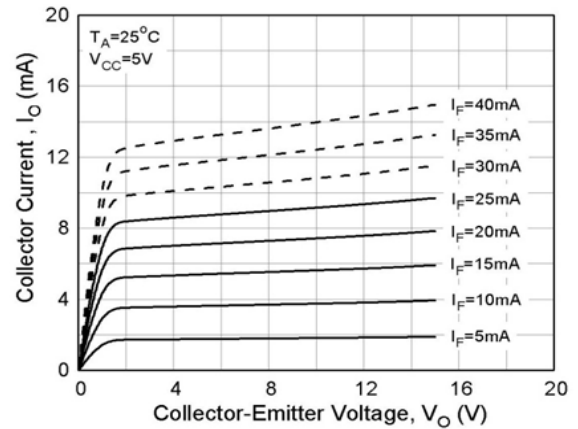

Fig 2 Output Current vs Output Voltage

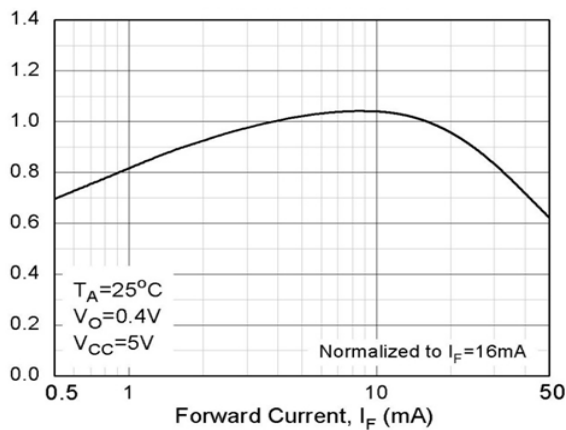

Fig 3 Normalized CTR vs Forward Current

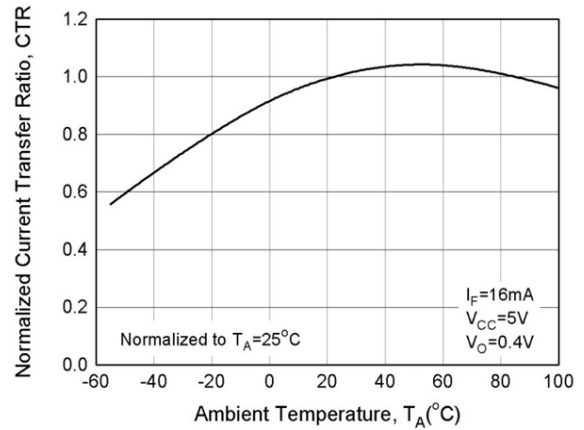

Fig 4 Normalized CTR vs Ambient Temperature

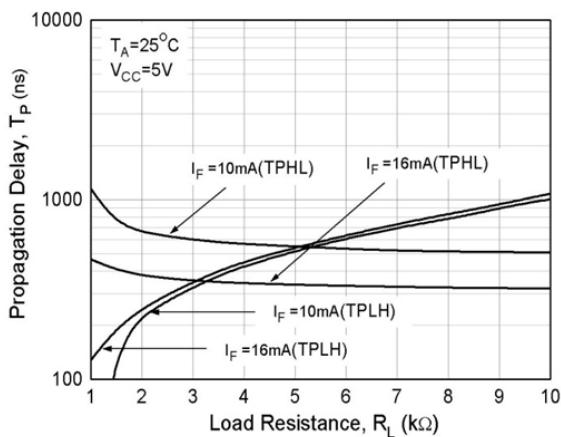

Fig 5 Propagation Delay vs Load Resistance

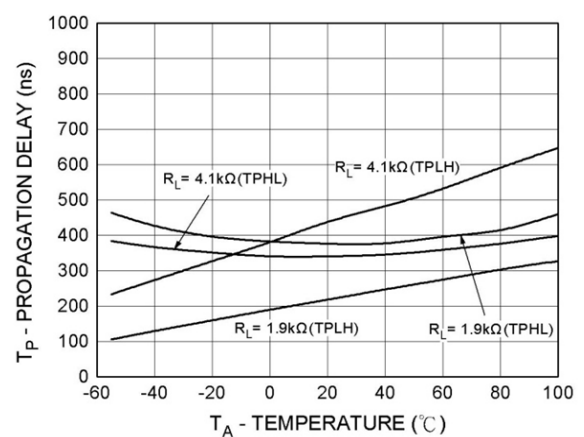

Fig 6 Propagation Delay vs Ambient Temperature



ICPL2530, ICPL2531

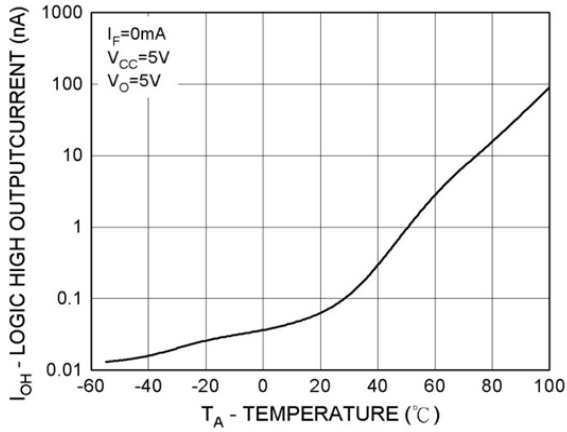

Fig 7 Logic High Output Current vs TA

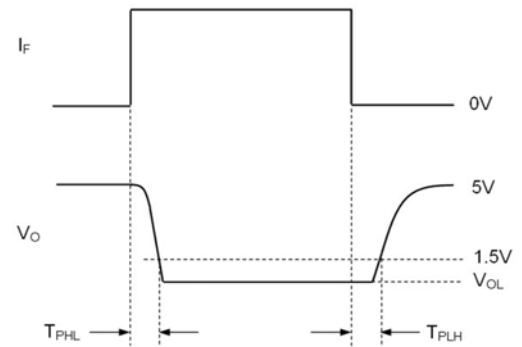
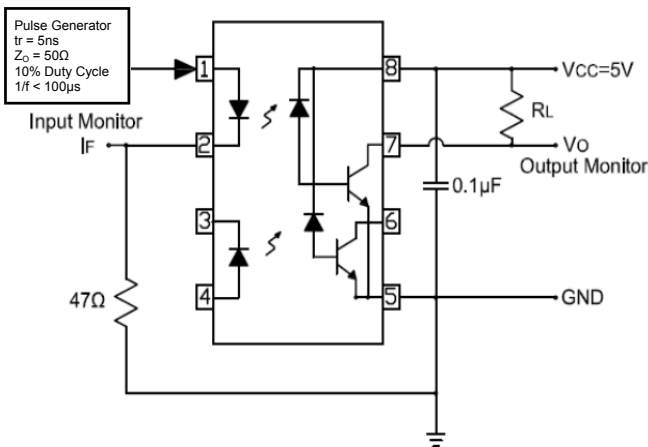

Fig 8 Switching Time Test Circuit

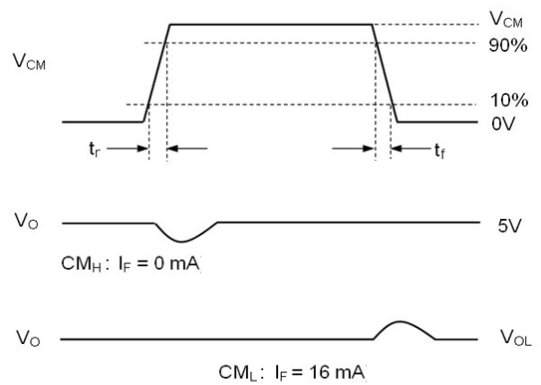
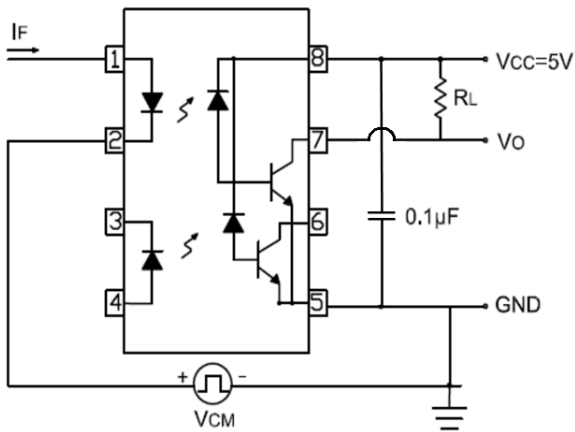

Fig 9 Transient Immunity Test Circuit



ICPL2530, ICPL2531

ORDER INFORMATION

ICPL2530			
After PN	PN	Description	Packing quantity
None	ICPL2530	Standard DIP8	45 pcs per tube
G	ICPL2530G	10mm Lead Spacing	45 pcs per tube
SM	ICPL2530SM	Surface Mount	45 pcs per tube
SMT&R	ICPL2530SMT&R	Surface Mount Tape & Reel	1000 pcs per reel

ICPL2531			
After PN	PN	Description	Packing quantity
None	ICPL2531	Standard DIP8	45 pcs per tube
G	ICPL2531G	10mm Lead Spacing	45 pcs per tube
SM	ICPL2531SM	Surface Mount	50 pcs per tube
SMT&R	ICPL2531SMT&R	Surface Mount Tape & Reel	1000 pcs per reel



ICPL2530, ICPL2531

PACKAGE DIMENSIONS (mm)

DIP

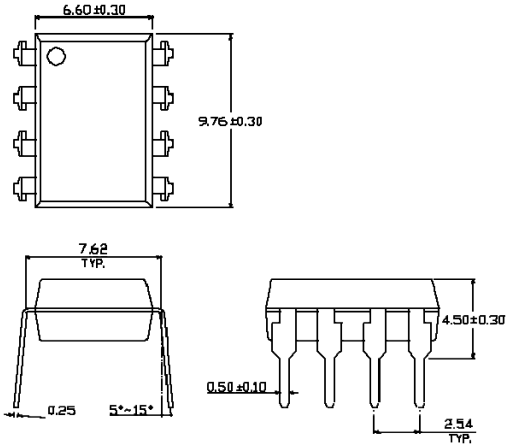

G FORM

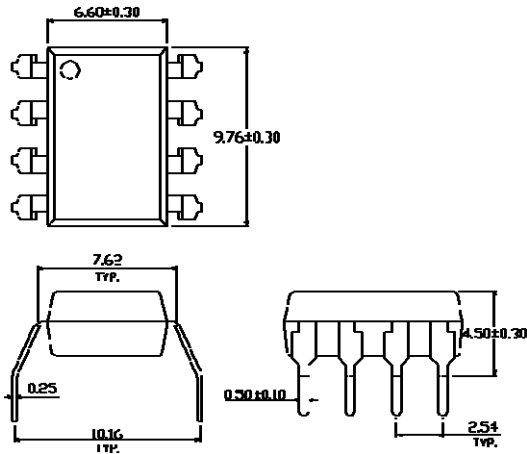

SMD

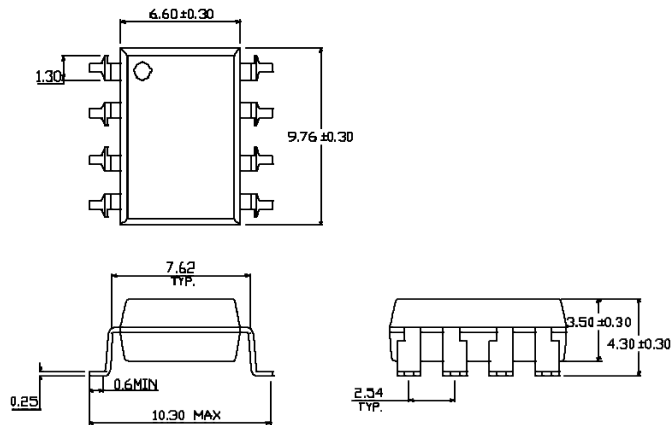



ICPL2530, ICPL2531

RECOMMENDED PAD LAYOUT FOR SMD (mm)

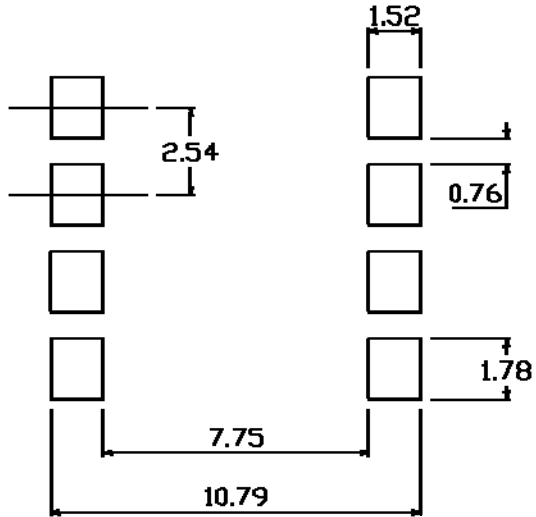

REFLOW SOLDERING TEMPERATURE PROFILE

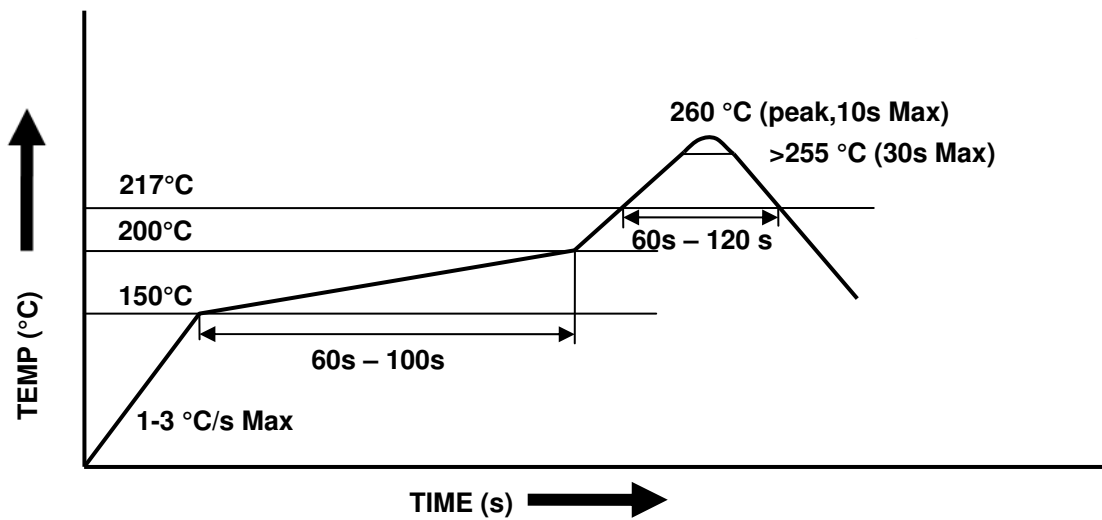



ICPL2530, ICPL2531

TAPE AND REEL PACKAGING

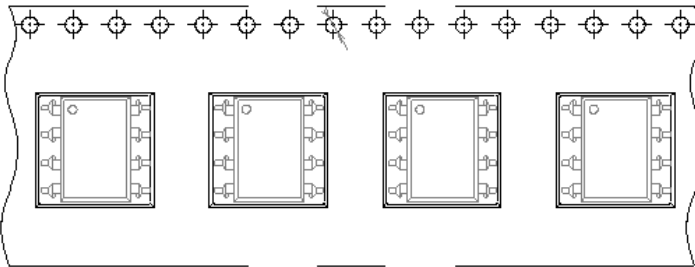

Direction of feed from reel

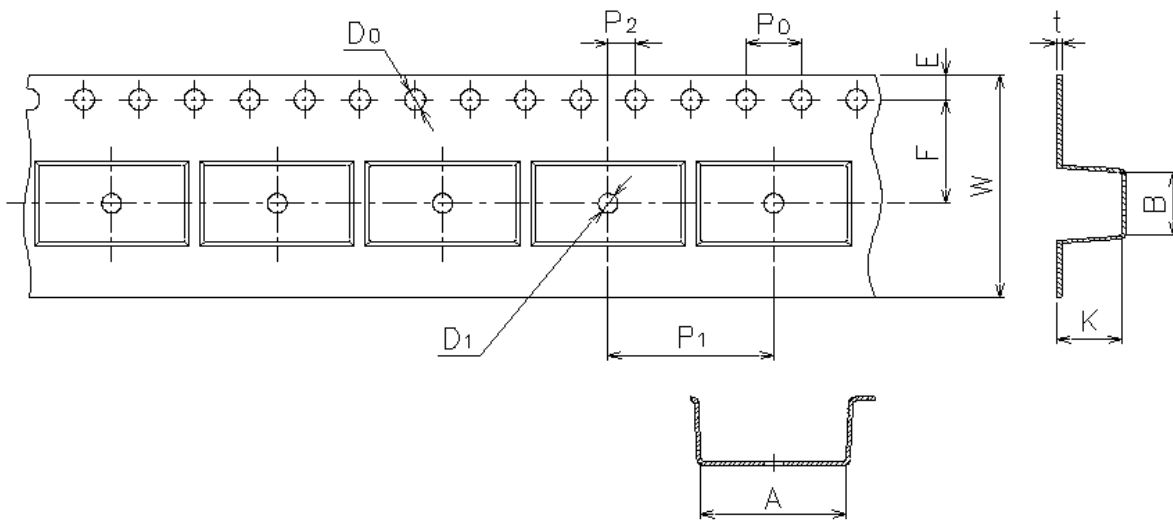

Dimension	A	B	D₀	D₁	E	F
(mm)	10.4±0.1	10.0±0.1	1.5±0.1	1.5±0.1	1.75±0.1	7.5±0.1
Dimension	P₀	P₁	P₂	t	W	K
(mm)	4.0±0.1	12.0±0.1	2.0±0.1	0.4±0.1	16.0 +0.3/-0.1	4.5±0.1



ISOCOM
—▶—□—||—
COMPONENTS

ICPL2530, ICPL2531

NOTES :

- Isocom is continually improving the quality, reliability, function or design and Isocom reserves the right to make changes without further notices.
- The products shown in this publication are designed for the general use in electronic applications such as office automation equipment, communications devices, audio/visual equipment, electrical application and instrumentation.
- For equipment/application where high reliability or safety is required, such as space applications, nuclear power control equipment, medical equipment, etc., please contact our sales representatives.
- When requiring a device for any "specific" application, please contact our sales for advice.
- The contents described herein are subject to change without prior notice.
- Do not immerse device's body in solder paste.