

THIS DRAWING IS UNPUBLISHED. RELEASED FOR PUBLICATION 2009  
 © COPYRIGHT 2009 BY TYCO ELECTRONICS CORPORATION. ALL INTERNATIONAL RIGHTS RESERVED.

LOC		DIST		REVISIONS			
P	LTR	DESCRIPTION	DATE	DWN	APVD		
A		FIRST ISSUE	12FEB2009	AV	GT		

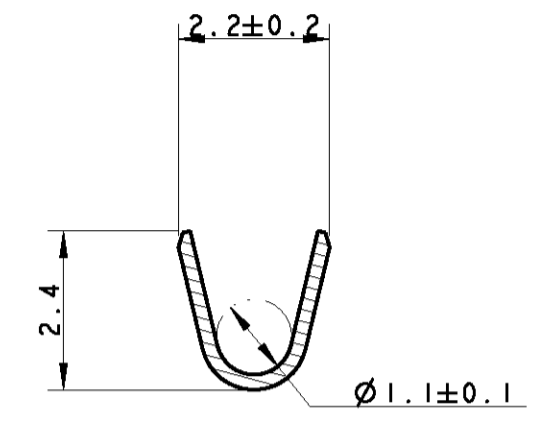

SECTION X-X

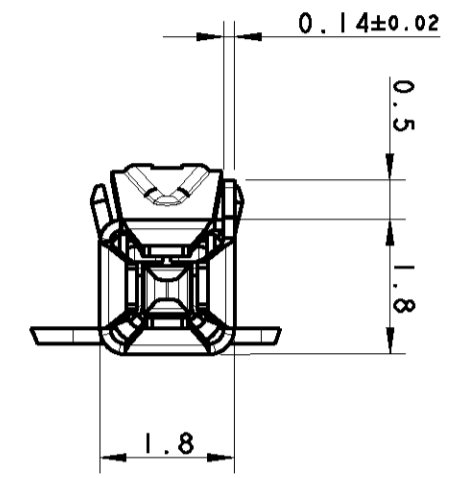
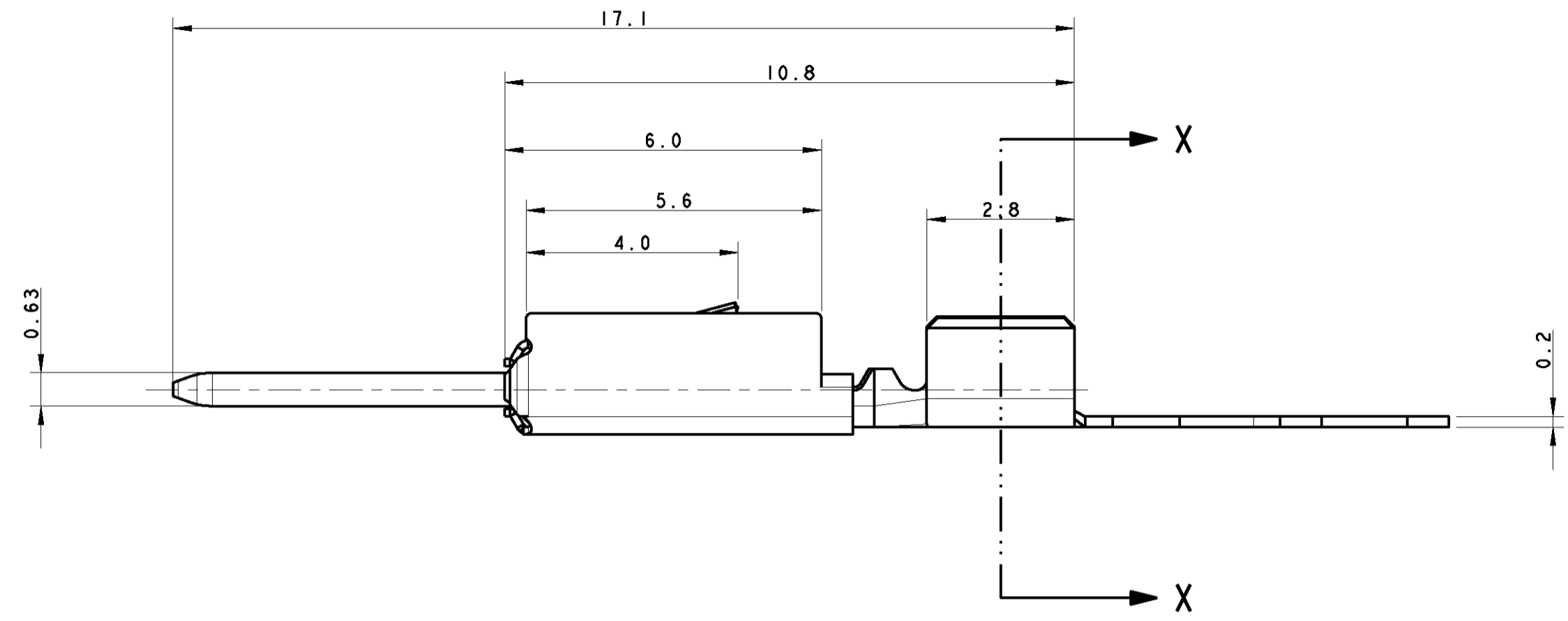
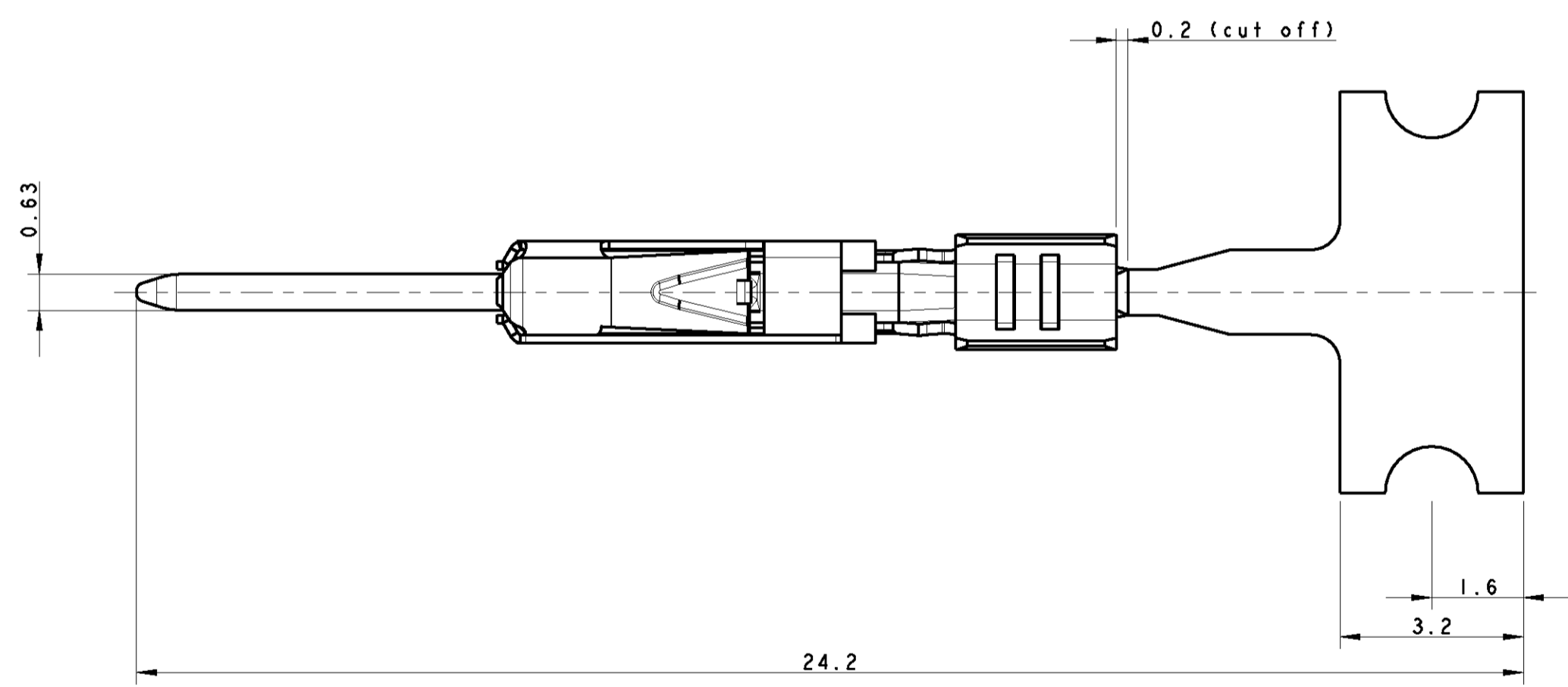

NOTES:

- SUITABLE FOR SOCKET CONTACT 293390
- CONTACT ACCEPTS WIRE SIZE 18 AWG
- SEMI-AUTOMATIC TOOL AND HAND TOOL (EACH FOR 2 CRIMPS IN ONE CYCLE) TO BE DEVELOPED
- STRIPPED CABLE LENGTH FOR CRIMP IS 3.5mm
- WEIGHT ABOUT 0.12g
- DIE FEED 7.0mm
- REELED ON PAPER-REEL

PRELIMINARY PART- NOT RELEASED FOR PRODUCTION

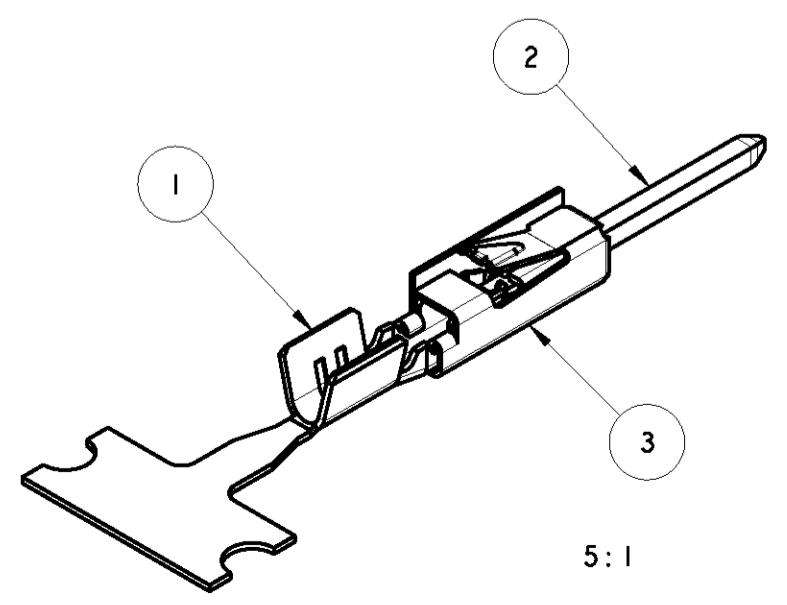

8	NOT AVAILABLE	293389-1	A	WITH SPRING	3	SPRING	M	steel	
	DIRECTION OFF TOP OF REEL	LOOSE PIECE	PART NO	REV	DESCRIPTION	2	PIN	A	CuNi3Si, (PRE TIN)
						1	BODY	A	CuNiSi AMP SPEC.100-1230 OR 100-1086 TIN PLATED
								MATERIAL	

DIRECTION OFF TOP OF REEL		DIMENSIONS: mm		TOLERANCES UNLESS OTHERWISE SPECIFIED:		DWN 12FEB2009 CHK A. Vecchia G. Turco APVD G. Turco 12FEB2009		Tyco Electronics Tyco Electronics AMP Italia S.r.l. 10093 Collegno TO	
8		0 PLC ± 1 PLC ±0.2 2 PLC ±0.15 3 PLC ± 4 PLC ±		FINISH		PRODUCT SPEC - APPLICATION SPEC - WEIGHT 0.12g		NAME MICRO QUADLOK SYSTEM PIN CONTACT	
107-3(Fig.1)		SEE TABLE		MATERIAL		SIZE A2 CAGE CODE 200779 DRAWING NO C-293389		RESTRICTED TO -	
CUSTOMER DRAWING								SCALE 10:1 SHEET 1 OF 1 REV A	