

LOC	DIST	REVISIONS					
		P	LTN	DESCRIPTION	DATE	DWN	APVD
CM	00	R1		REVISED PER ECR-12-011660	24JAN2013	KH	TM
		R2		REVISED PER ECR-21-119230	08NOV2021	SS	VS

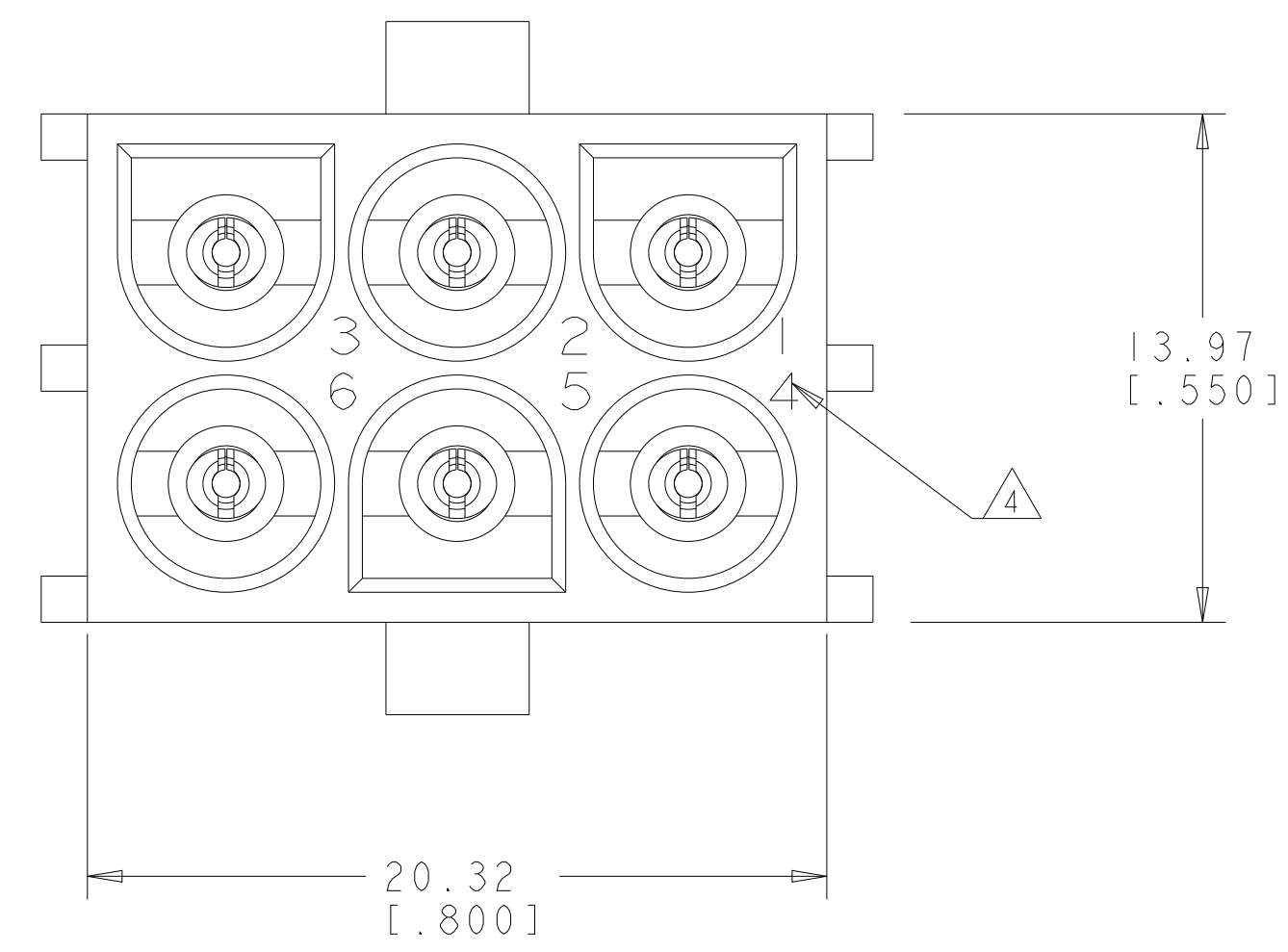

- PARTS MATE WITH HOUSING 480704.
- PARTS COMPLY TO AMP SOLDERABILITY SPECIFICATION 109-11-3.
- CONTACT IS PLATED OVERALL WITH 0.00127 [.000050] NICKEL, THEN 0.00076 [.000030] GOLD OVER CONTACT LENGTH INDICATED AND TIN LEAD ON SOLDER TAIL END.
- CIRCUIT IDENTIFICATION CHARACTERS ARE ADJACENT TO THE INDICATED CAVITIES, BUT LOCATION AND ORIENTATION MAY DIFFER FROM PRINT.
- CONTACT IS PLATED OVERALL WITH 0.00127 [.000050] NICKEL, THEN 0.00076 [.000030] GOLD OVER CONTACT LENGTH INDICATED AND MATTE TIN ON SOLDER TAIL END.
- DIMENSIONS IN BRACKETS ARE IN INCHES.
- SUPERSEDED BY 350585-4
- DIMENSIONS SHOWN REPRESENT PRODUCT IN DRY CONDITION. ADDITIONAL 2% GROWTH DUE TO END USE LOCATION MOISTURE ABSORPTION MAY OCCUR AND SHOULD BE ACCOUNTED FOR.

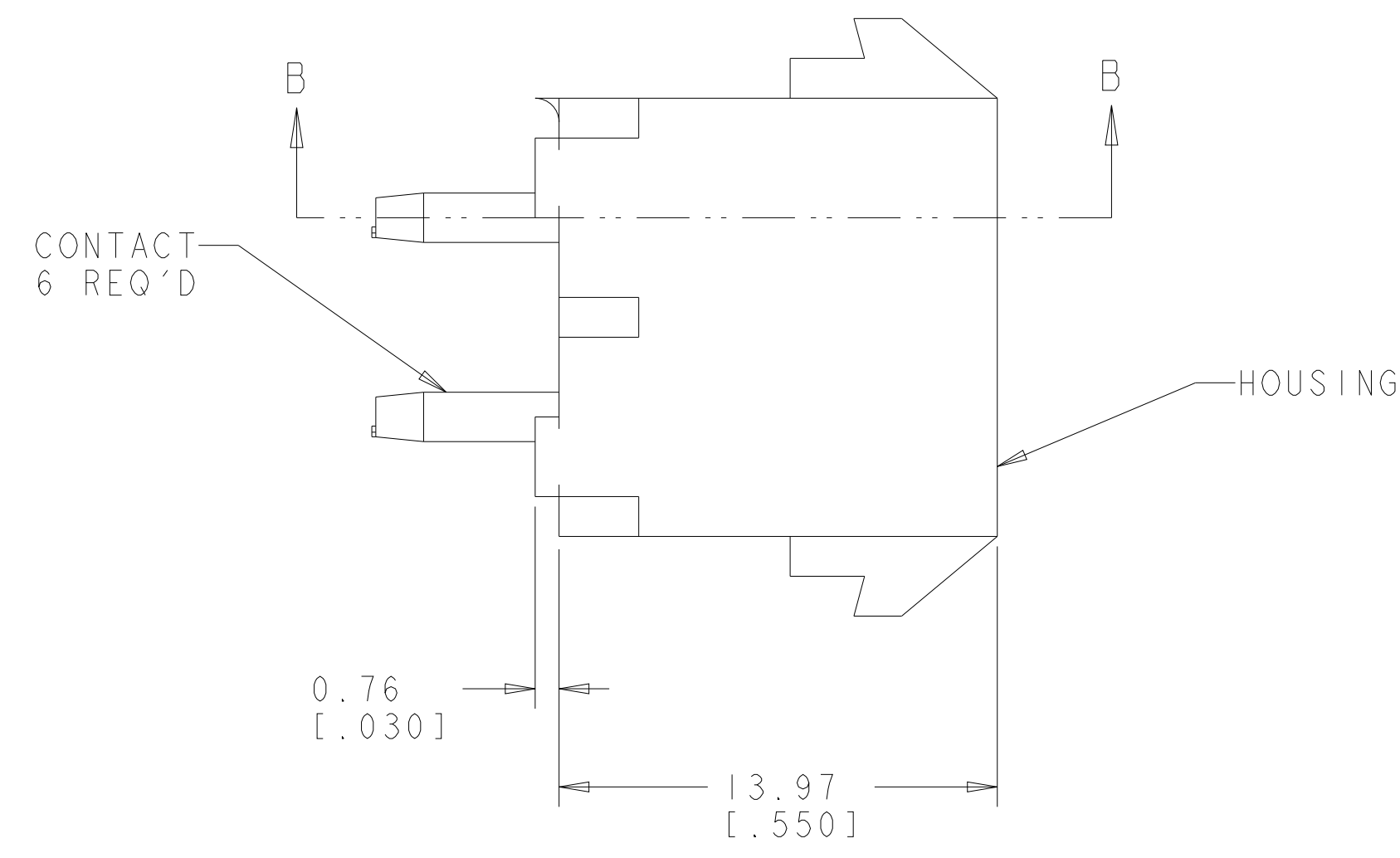
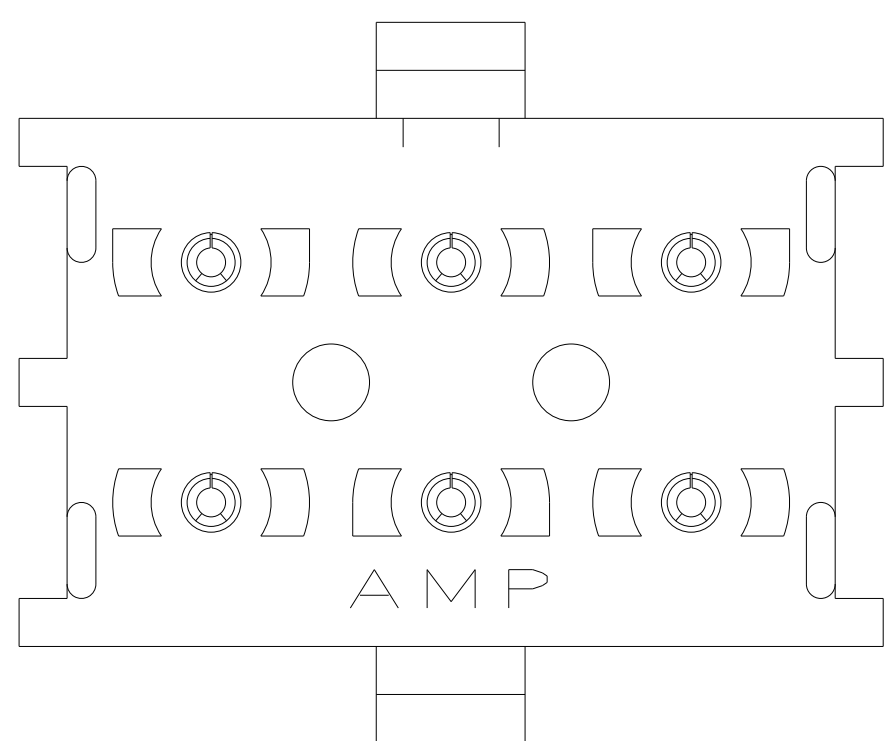
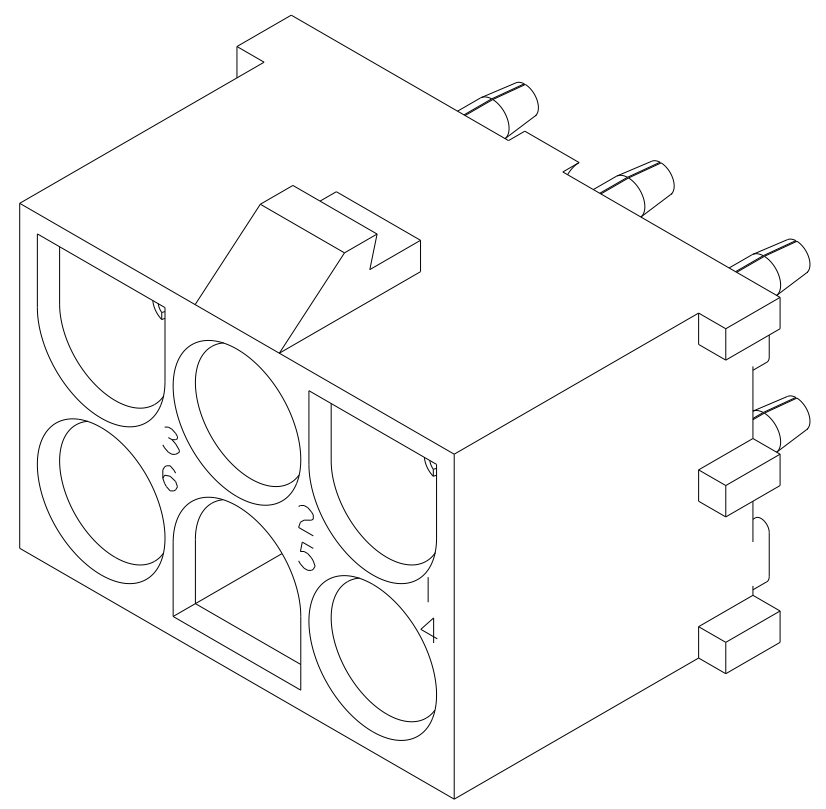
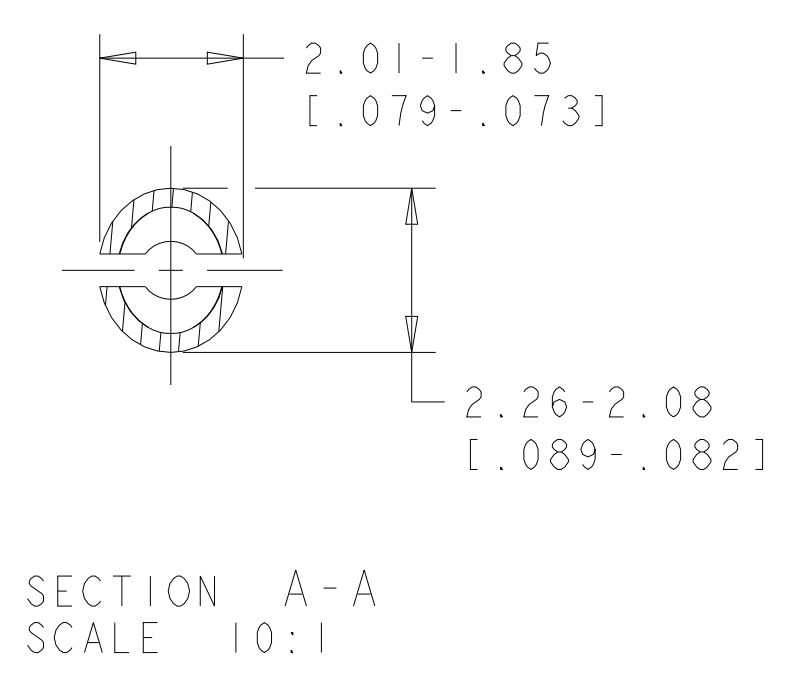
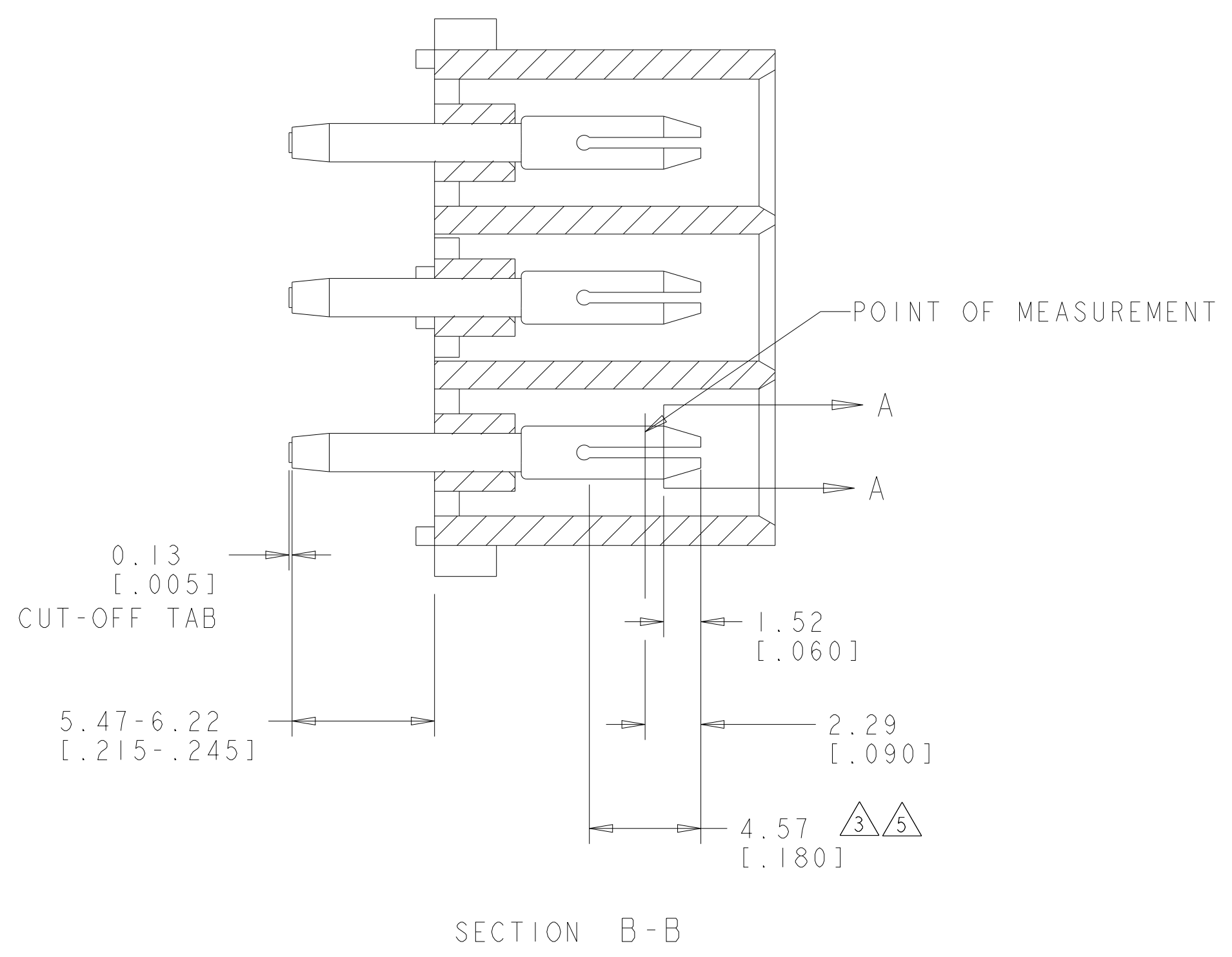

3 DIMENSIONAL MODEL
SCALE 4:1

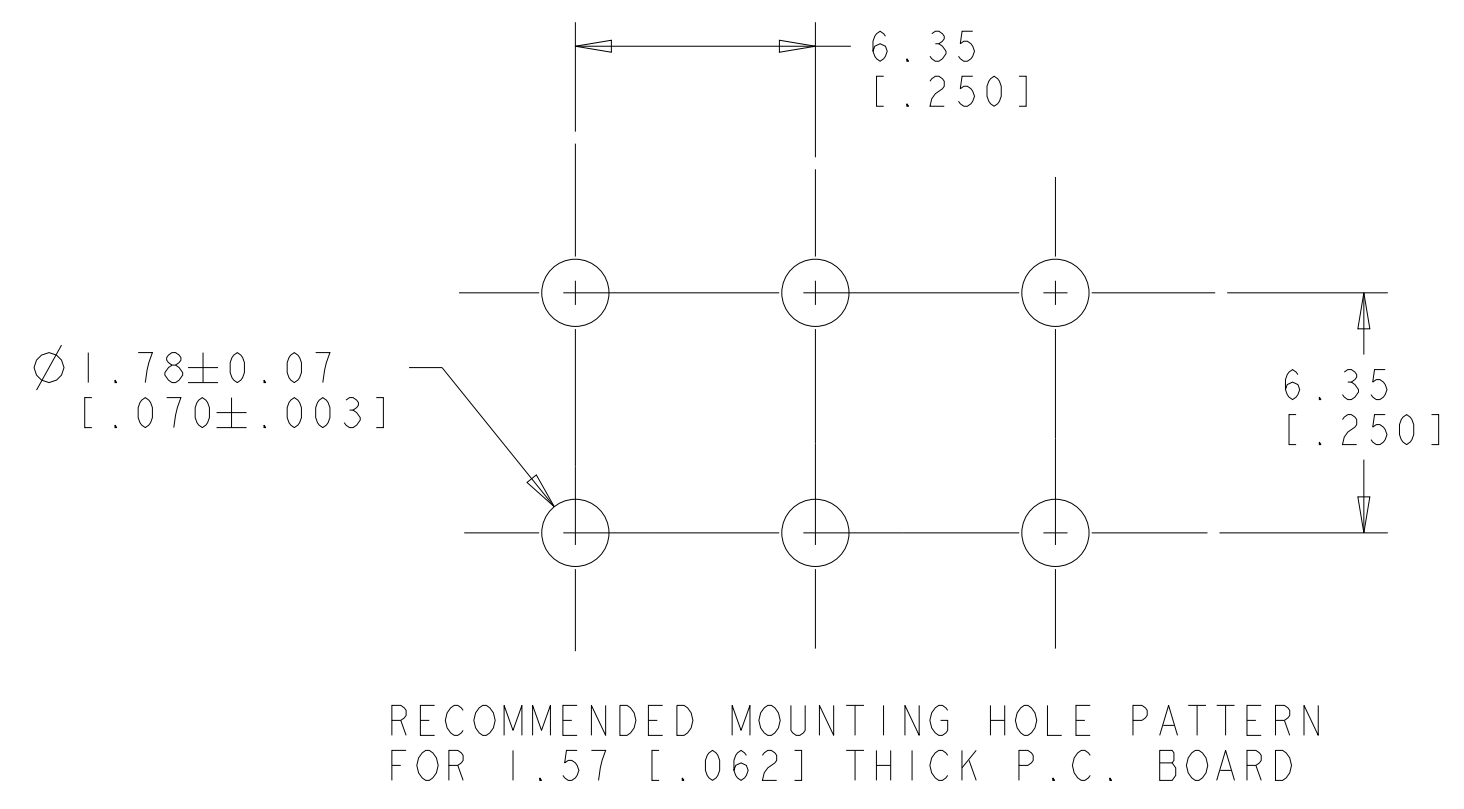

PIN CONTACT MATERIAL AND FINISH	HOUSING MATERIAL AND COLOR	PART NUMBER
PHOSPOR BRONZE, GOLD $\Delta 5$	NYLON, UL94V-2, NATURAL	350585-4
$\Delta 7$ PHOSPOR BRONZE, GOLD $\Delta 3$	NYLON, UL94V-2, NATURAL	350585-2
PHOSPOR BRONZE, PRE-TIN	NYLON, UL94V-2, NATURAL	350585-1

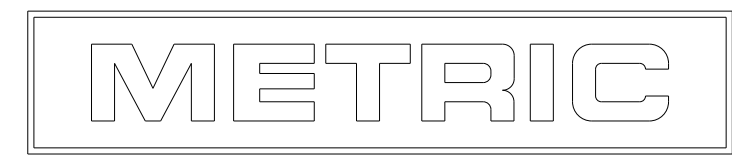

THIS DRAWING IS A CONTROLLED DOCUMENT.

DIMENSIONS: mm [INCHES]	TOLERANCES UNLESS OTHERWISE SPECIFIED:	DWN K. WHITAKER 02SEP2005	CHK S. RIDGILL 02SEP2005	APVD S. RIDGILL 02SEP2005	NAME PIN HEADER ASSEMBLY, 6 CIRCUIT, UNIVERSAL MATE-N-LOK(TM)
MATERIAL SEE TABLE	FINISH SEE TABLE	SIZE A1	CAGE CODE 00779	DRAWING NO 350585	RESTRICTED TO

CUSTOMER DRAWING SCALE 5:1 SHEET 1 OF 1 REV R2