

28 V Input High Speed Voltage Regulator

FEATURES

- Operating Voltage Range 2.0 V – 28.0 V
- Output Voltage Range from 1.8 V to 18.0 V with 0.1 V increments
- Output Voltage Accuracy $\pm 2\%$
- Temperature Stability ± 30 ppm/ $^{\circ}\text{C}$
- Low Power Consumption of 50 μA at $V_{\text{OUT}} = 5.0$ V
- Output Current up to 150 mA (200 mA limit)
- Standby Current less than 0.1 μA typical
- Power Supply Ripple Rejection 50 dB at 1 kHz
- Current Limit and Short Circuit Protection
- Low ESR Ceramic Capacitor compatible
- ON/OFF switch,
- Thermal shutdown
- Operating Ambient Temperature - 40 + 85 $^{\circ}\text{C}$
- Packages : SOT-25, SOT- 89, SOT-89-5, and USP-6C
- EU RoHS Compliant, Pb Free

APPLICATIONS

- Mobile phones
- Car Audio and Navigation Systems
- Cameras, VCRs
- Various portable equipment

TYPICAL APPLICATION CIRCUIT

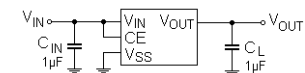

The IXD1701B with CE function

DESCRIPTION

The IXD1701 is positive voltage regulator with operation voltage up to 28V, manufactured by CMOS process.

The IC consists of a voltage reference, an error amplifier, a current limiter, a thermal protection, a phase compensation circuit, and a driver transistor.

The output voltage is selectable in 0.1 V increments within the range from 1.8 V to 18 V. High precision output voltage achieved by laser trimming technology.

The IXD1701 is stable with low ESR ceramic output capacitor (C_L). The over current protection circuit and the thermal shutdown are built-in. These two protection circuits operate when the output current reaches current limit level or the junction temperature reaches temperature limit.

The Chip Enable (CE) function allows set IXD1701 into standby mode, reducing current consumption to less than 0.1 μA typically.

The IXD1701 is available in SOT-25, SOT-89, SOT-89-5, USP-6C, SOT-223, and TO-252 packages.

TYPICAL PERFORMANCE CHARACTERISTIC

Load Transient Response (IXD1701B/D502)

$V_{\text{IN}} = 7.0$ V, $t_{\text{R}} = t_{\text{F}} = 5$ μs , $C_{\text{IN}} = C_{\text{L}} = 1$ μF , $I_{\text{OUT}} = 0$ mA \leftrightarrow 30 mA, $T_{\text{a}} = 25^{\circ}\text{C}$,

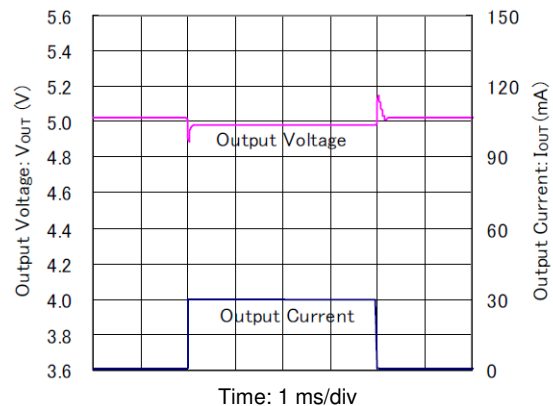

ABSOLUTE MAXIMUM RATINGS

PARAMETER		SYMBOL	RATINGS	UNITS
Input Voltage		V_{IN}	- 0.3 ~ +30	V
Output Current		I_{OUT}	300 ¹⁾	mA
Output Voltage		V_{OUT}	- 0.3 ~ $V_{IN} + 0.3$ or +30 ²⁾	V
CE Input Voltage (IXD1701B version only)		V_{CE}	- 0.3 ~ +30	V
Power Dissipation ²⁾	SOT-25	P_D	250	mW
			600 (PCB mounted)	
	SOT-89		500	
			1000 (PCB mounted)	
	SOT-89-5		500	
			1300 (PCB mounted)	
	USP-6C		120	
			1000 (PCB mounted)	
	SOT223		300	
1500 (PCB mounted)				
TO-252	500			
	1800 (PCB mounted)			
Operating Temperature Range		T_{OPR}	- 40 ~ + 85	°C
Storage Temperature Range		T_{STG}	- 55 ~ +125	°C

All voltages are in respect to V_{SS}

- 1) $I_{OUT} \leq P_d / (V_{IN} - V_{OUT})$
- 2) The lowest value between $V_{IN} + 0.3$ and 30 V
- 3) This is a reference data taken by using the test board. Please refer to page 25 to 30 for details

ELECTRICAL OPERATING CHARACTERISTICS

Ta = 25 °C

PARAMETER	SYMBOL	CONDITIONS	MIN.	TYP.	MAX.	UNIT	CIRCUIT	
Input Voltage	V _{IN}		2.0		28.0	V	①	
Output Voltage ¹⁾	V _{OUT(E)}	V _{CE} = V _{IN} , I _{OUT} = 10 mA	E-0			V	①	
Maximum Output Current	I _{OUT_MAX}	V _{CE} = V _{IN} = V _{OUT(T)} + 3 V	V _{OUT(T)} ≥ 3 V	150		mA	①	
			V _{OUT(T)} < 3 V	100				
Load Regulation	ΔV _{OUT}	V _{CE} = V _{IN} , 1 mA ≤ I _{OUT} ≤ 50 mA	1.8 V ≤ V _{OUT(T)} ≤ 5 V		50	90	mV	①
			5.1 V ≤ V _{OUT(T)} ≤ 12.0 V		50	175		
			12.1 V ≤ V _{OUT(T)} ≤ 18.0 V		180	275		
Dropout Voltage ²⁾	V _{DIF1}	V _{CE} = V _{IN} , I _{OUT} = 20 mA	E-1 ⁴⁾			mV	①	
	V _{DIF2}	V _{CE} = V _{IN} , I _{OUT} = 100 mA	E-2 ⁴⁾					
Supply Current	I _{SS}		1.8 V ≤ V _{OUT(T)} ≤ 5 V	11	50	105	μA	②
			5.1 V ≤ V _{OUT(T)} ≤ 12.0 V	11	60	115		
			12.1 V ≤ V _{OUT(T)} ≤ 18.0 V	11	65	125		
Standby Current	I _{STB}	V _{CE} = 0 V		0.01	0.10	μA	②	
Line Regulation	$\frac{\Delta V_{OUT}}{V_{OUT} * \Delta V_{IN}}$	V _{OUT(T)} + 2 V ≤ V _{IN} ≤ 28 V, V _{CE} = V _{IN}	I _{OUT} = 5 mA		0.05	0.10	% / V	①
			I _{OUT} = 13 mA		0.15	0.30		
Output Voltage Temperature Characteristics	$\frac{\Delta V_{OUT}}{V_{OUT} * \Delta T_{OPR}}$	V _{CE} = V _{IN} , I _{OUT} = 30 mA - 40 °C ≤ T _{OPR} ≤ 85 °C		± 100		ppm/°C	①	
Power Supply Rejection Ratio	PSRR	V _{CE} = V _{IN} , I _{OUT} = 20 mA, f = 1 kHz V _{IN} = (V _{OUT(T)} + 2) V _{DC} + 0.5 V p-p _{AC}		50		dB	③	
Short Circuit Current	I _{SHORT}	V _{CE} = V _{IN} , V _{IN} = V _{OUT(T)} + 2 V		40		mA	①	
Thermal Shutdown Detect Temperature	T _{TSD}	Junction Temperature		150		°C		
Thermal Shutdown Hysteresis	T _{HYS}			25		°C		
CE "H" Level Voltage ⁵⁾	V _{CEH}		1.1		V _{IN}	V	①	
CE "L" Level Voltage ⁵⁾	V _{CEL}		0		0.35	V	①	
CE "H" Level Current ⁵⁾	I _{CEH}	V _{CE} = V _{IN} = 6.0 V	-0.1		0.1	μA	①	
CE "L" Level Current ⁵⁾	I _{CEL}	V _{IN} = 6.0 V, V _{CE} = V _{SS}	-0.1		0.1	μA	①	

NOTE:

Unless otherwise stated, V_{IN} = V_{CE} = V_{OUT(T)} + 2.0 V

- V_{OUT(T)} is Nominal output voltage and V_{OUT(E)} is Effective output voltage, (i.e. the output voltage when "V_{OUT(T)} + 1.0V" is provided at the V_{IN} pin, while maintaining a certain I_{OUT} value).
- V_{DIF} = {V_{IN} - V_{OUT}}, where V_{IN1} is the input voltage when V_{OUT} = 0.98 V_{OUT(T)} appears, while input voltage gradually decreases
- Refer to the Table "Voltage Chart, Output Voltage"
- Refer to the Table "Voltage Chart, Dropout Voltage"
- IXD1701B version only

ELECTRICAL OPERATING CHARACTERISTICS (CONTINUED)

Voltage Chart

Ta = 25°C

SYMBOL OUTPUT VOLTAGE V _{OUT(T)} (V)	E-0		E-1		E-2	
	OUTPUT VOLTAGE, V		DROPOUT VOLTAGE, mV		DROPOUT VOLTAGE, mV	
	V _{OUT}		I _{OUT} = 20 mA		I _{OUT} = 100 mA	
			Vdif1		Vdif2	
	MIN.	MAX.	TYP.	MAX.	TYP.	MAX.
1.8	1.764	1.836	550	710	2200	2700
1.9	1.862	1.938	550	710	2200	2700
2.0	1.960	2.040	450	600	1900	2600
2.1	2.058	2.142	450	600	1900	2600
2.2	2.156	2.244	390	520	1700	2200
2.3	2.254	2.346	390	520	1700	2200
2.4	2.352	2.448	390	520	1700	2200
2.5	2.450	2.550	310	450	1500	1900
2.6	2.548	2.652	310	450	1500	1900
2.7	2.646	2.754	310	450	1500	1900
2.8	2.744	2.856	310	450	1500	1900
2.9	2.842	2.958	310	450	1500	1900
3.0	2.940	3.060	260	360	1300	1700
3.1	3.038	3.162	260	360	1300	1700
3.2	3.136	3.264	260	360	1300	1700
3.3	3.234	3.366	260	360	1300	1700
3.4	3.332	3.468	260	360	1300	1700
3.5	3.430	3.570	260	360	1300	1700
3.6	3.528	3.672	260	360	1300	1700
3.7	3.626	3.774	260	360	1300	1700
3.8	3.724	3.876	260	360	1300	1700
3.9	3.822	3.978	260	360	1300	1700
4.0	3.920	4.080	220	320	1100	1500
4.1	4.018	4.182	220	320	1100	1500
4.2	4.116	4.284	220	320	1100	1500
4.3	4.214	4.386	220	320	1100	1500
4.4	4.312	4.488	220	320	1100	1500
4.5	4.410	4.590	220	320	1100	1500
4.6	4.508	4.692	220	320	1100	1500
4.7	4.606	4.794	220	320	1100	1500
4.8	4.704	4.896	220	320	1100	1500
4.9	4.802	4.998	220	320	1100	1500
5.0	4.900	5.100	190	280	1000	1300
5.1	4.998	5.202	190	280	1000	1300
5.2	5.096	5.304	190	280	1000	1300
5.3	5.194	5.406	190	280	1000	1300
5.4	5.292	5.508	190	280	1000	1300
5.5	5.390	5.610	190	280	1000	1300
5.6	5.488	5.712	190	280	1000	1300
5.7	5.586	5.814	190	280	1000	1300
5.8	5.684	5.916	190	280	1000	1300
5.9	5.782	6.018	190	280	1000	1300
6.0	5.880	6.120	190	280	1000	1300

ELECTRICAL OPERATING CHARACTERISTICS (CONTINUED)

Voltage Chart (Continued)

Ta = 25°C

SYMBOL OUTPUT VOLTAGE V _{OUT(T)} (V)	E-0		E-1		E-2	
	OUTPUT VOLTAGE, V		DROPOUT VOLTAGE, mV		DROPOUT VOLTAGE, mV	
	V _{OUT}		I _{OUT} = 20 mA		I _{OUT} = 100 mA	
			V _{dif1}		V _{dif2}	
	MIN.	MAX.	TYP.	MAX.	TYP.	MAX.
6.1	5.978	6.222	190	280	1000	1300
6.2	6.076	6.324	190	280	1000	1300
6.3	6.174	6.426	190	280	1000	1300
6.4	6.272	6.528	190	280	1000	1300
6.5	6.370	6.630	170	230	800	1150
6.6	6.468	6.732	170	230	800	1150
6.7	6.566	6.834	170	230	800	1150
6.8	6.664	6.936	170	230	800	1150
6.9	6.762	7.038	170	230	800	1150
7.0	6.860	7.140	170	230	800	1150
7.1	6.958	7.242	170	230	800	1150
7.2	7.056	7.344	170	230	800	1150
7.3	7.154	7.446	170	230	800	1150
7.4	7.252	7.548	170	230	800	1150
7.5	7.350	7.650	170	230	800	1150
7.6	7.448	7.752	170	230	800	1150
7.7	7.546	7.854	170	230	800	1150
7.8	7.644	7.956	170	230	800	1150
7.9	7.742	8.058	170	230	800	1150
8.0	7.840	8.160	170	230	800	1150
8.1	7.938	8.262	130	190	700	950
8.2	8.036	8.364	130	190	700	950
8.3	8.134	8.466	130	190	700	950
8.4	8.232	8.568	130	190	700	950
8.5	8.330	8.670	130	190	700	950
8.6	8.428	8.772	130	190	700	950
8.7	8.526	8.874	130	190	700	950
8.8	8.624	8.976	130	190	700	950
8.9	8.722	9.078	130	190	700	950
9.0	8.820	9.180	130	190	700	950
9.1	8.918	9.282	130	190	700	950
9.2	9.016	9.384	130	190	700	950
9.3	9.114	9.486	130	190	700	950
9.4	9.212	9.588	130	190	700	950
9.5	9.310	9.690	130	190	700	950
9.6	9.408	9.792	130	190	700	950
9.7	9.506	9.894	130	190	700	950
9.8	9.604	9.996	130	190	700	950
9.9	9.702	10.098	130	190	700	950
10.0	9.800	10.200	130	190	700	950

ELECTRICAL OPERATING CHARACTERISTICS (CONTINUED)

Voltage Chart (Continued)

Ta = 25°C

SYMBOL OUTPUT VOLTAGE V _{OUT(T)} (V)	E-0		E-1		E-2	
	OUTPUT VOLTAGE, V		DROPOUT VOLTAGE, mV		DROPOUT VOLTAGE, mV	
			I _{OUT} = 20 mA		I _{OUT} = 100 mA	
	V _{OUT}		V _{dif1}		V _{dif2}	
	MIN.	MAX.	TYP.	MAX.	TYP.	MAX.
10.1	9.898	10.302	120	170	650	850
10.2	9.996	10.404	120	170	650	850
10.3	10.094	10.506	120	170	650	850
10.4	10.192	10.608	120	170	650	850
10.5	10.290	10.710	120	170	650	850
10.6	10.388	10.812	120	170	650	850
10.7	10.486	10.914	120	170	650	850
10.8	10.584	11.016	120	170	650	850
10.9	10.682	11.118	120	170	650	850
11.0	10.780	11.220	120	170	650	850
11.1	10.878	11.322	120	170	650	850
11.2	10.976	11.424	120	170	650	850
11.3	11.074	11.526	120	170	650	850
11.4	11.172	11.628	120	170	650	850
11.5	11.270	11.730	120	170	650	850
11.6	11.368	11.832	120	170	650	850
11.7	11.466	11.934	120	170	650	850
11.8	11.564	12.036	120	170	650	850
11.9	11.662	12.138	120	170	650	850
12.0	11.760	12.240	120	170	650	850
12.1	11.858	12.342	120	170	650	850
12.2	11.956	12.444	120	170	650	850
12.3	12.054	12.546	120	170	650	850
12.4	12.152	12.648	120	170	650	850
12.5	12.250	12.750	120	170	650	850
12.6	12.348	12.852	120	170	650	850
12.7	12.446	12.954	120	170	650	850
12.8	12.544	13.056	120	170	650	850
12.9	12.642	13.158	120	170	650	850
13.0	12.740	13.260	120	170	650	850
13.1	12.838	13.362	120	170	650	850
13.2	12.936	13.464	120	170	650	850
13.3	13.034	13.566	120	170	650	850
13.4	13.132	13.668	120	170	650	850
13.5	13.230	13.770	120	170	650	850
13.6	13.328	13.872	120	170	650	850
13.7	13.426	13.974	120	170	650	850
13.8	13.524	14.076	120	170	650	850
13.9	13.622	14.178	120	170	650	850
14.0	13.720	14.280	120	170	650	850

ELECTRICAL OPERATING CHARACTERISTICS (CONTINUED)

Voltage Chart (Continued)

Ta = 25°C

SYMBOL OUTPUT VOLTAGE V _{OUT(T)} (V)	E-0		E-1		E-2	
	OUTPUT VOLTAGE, V		DROPOUT VOLTAGE, mV		DROPOUT VOLTAGE, mV	
	V _{OUT}		I _{OUT} = 20 mA		I _{OUT} = 100 mA	
			V _{dif1}		V _{dif2}	
	MIN.	MAX.	TYP.	MAX.	TYP.	MAX.
14.1	13.818	14.382	120	170	650	850
14.2	13.916	14.484	120	170	650	850
14.3	14.014	14.586	120	170	650	850
14.4	14.112	14.688	120	170	650	850
14.5	14.210	14.790	120	170	650	850
14.6	14.308	14.892	120	170	650	850
14.7	14.406	14.994	120	170	650	850
14.8	14.504	15.096	120	170	650	850
14.9	14.602	15.198	120	170	650	850
15.0	14.700	15.300	120	170	650	850
15.1	14.798	15.402	120	170	650	850
15.2	14.896	15.504	120	170	650	850
15.3	14.994	15.606	120	170	650	850
15.4	15.092	15.708	120	170	650	850
15.5	15.190	15.810	120	170	650	850
15.6	15.288	15.912	120	170	650	850
15.7	15.386	16.014	120	170	650	850
15.8	15.484	16.116	120	170	650	850
15.9	15.582	16.218	120	170	650	850
16.0	15.680	16.320	120	170	650	850
16.1	15.778	16.422	120	170	650	850
16.2	15.876	16.524	120	170	650	850
16.3	15.974	16.626	120	170	650	850
16.4	16.072	16.728	120	170	650	850
16.5	16.170	16.830	120	170	650	850
16.6	16.268	16.932	120	170	650	850
16.7	16.366	17.034	120	170	650	850
16.8	16.464	17.136	120	170	650	850
16.9	16.562	17.238	120	170	650	850
17.0	16.660	17.340	120	170	650	850
17.1	16.758	17.442	120	170	650	850
17.2	16.856	17.544	120	170	650	850
17.3	16.954	17.646	120	170	650	850
17.4	17.052	17.748	120	170	650	850
17.5	17.150	17.850	120	170	650	850
17.6	17.248	17.952	120	170	650	850
17.7	17.346	18.054	120	170	650	850
17.8	17.444	18.156	120	170	650	850
17.9	17.542	18.258	120	170	650	850
18.0	17.640	18.360	120	170	650	850

PIN CONFIGURATION

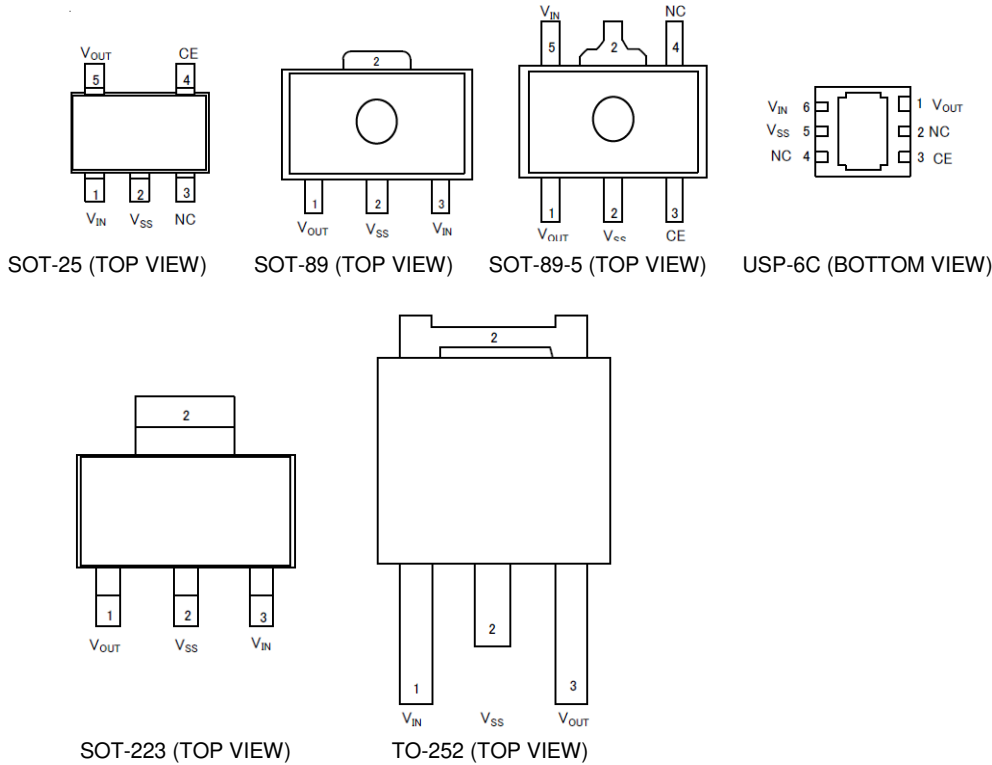

The dissipation pad for the USP-6C package should be solder-plated in respect with mounting pattern and metal mask to improve heat dissipation and mounting strength. If the pad needs to be connected to other pins, it should be connected to the V_{SS} (No. 5) pin.

PIN ASSIGNMENT

PIN NUMBER						PIN NAME	FUNCTIONS
SOT-25	SOT-89	SOT-89-5	USP-6C	SOT-223	TO-252		
1	3	5	6	3	1	V _{IN}	Power Input
5	1	1	1	1	3	V _{OUT}	Output Voltage
2	2	2	5	2	2	V _{SS}	Ground
4		3	3			CE	ON/OFF Control LOW – Standby mode, HIGH – Active ¹⁾
3		1				NC	No Connection

1) CE pin does not have internal pull-down resistor. IC state is undefined, if this pin is open.

BLOCK DIAGRAMS

IXD1701B

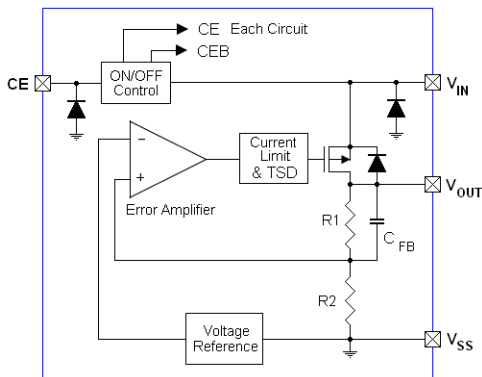

IXD1701D

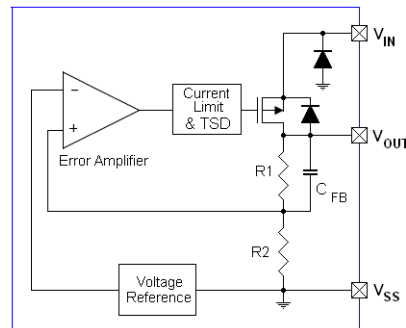

Diodes inside the circuits are ESD protection diodes and parasitic diodes.

BASIC OPERATION

The Error Amplifier of the IXD1701 series monitors output voltage divided by internal resistors R1 & R2 and compares it with the internal Reference Voltage (see Block Diagram above). The output signal from error amplifier drives gate of the P-channel MOSFET, which is connected to the V_{OUT} pin and operates as a series voltage regulator.

The Current Limit/Short Protection circuits monitor level of the output current, and Thermal shutdown circuit monitors MOSFET junction temperature to prevent IC damage by excessive current.

The CE pin allows shutdown internal circuitry to minimize power consumption.

Current Limiter, Short-Circuit Protection

The IXD1701 series have a current limiter circuit & a fold back circuit, which aid the operations of the current limiter and circuit protection. When the load current reaches the current limit level, the fixed current limiter circuit activates and output voltage drops. Because of this drop, the fold back circuit activates too, and output voltage drops further decreasing output current. When the output pin is shorted, a current of about 30 mA flows.

Thermal Shutdown

When the junction temperature of the built-in transistor reaches the temperature limit, the thermal shutdown circuit activates and turns transistor OFF. The IC resumes normal operation when the junction temperature falls below value determined by Thermal Shutdown Hysteresis.

CE Pin

The CE pin allows shutdown internal circuitry to minimize power consumption. In shutdown mode, output at the V_{OUT} pin is pulled down to the V_{SS} level by resistors R1 and R2 connected in series.

Note that the CE input is active HIGH and has no pull down resistor. IC will be in undefined state, if CE pin is open. CE pin should be connected to either V_{IN} or ground. IC current consumption may increase, if voltage applied to this pin is ~ 0.5 of V_{IN}.

Minimum Operating Voltage

The input voltage should be above 2.0 V for the stable IC operation.

TYPICAL APPLICATION CIRCUIT

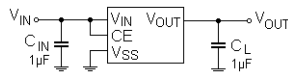

LAYOUT AND USE CONSIDERATIONS

1. Mount external component as close to the IC as possible and use thick, short connecting traces to reduce the circuit impedance.
2. The IC may malfunction if absolute maximum ratings are exceeded.
3. If power source of this regulator is a high impedance device, an input capacitor $C_{IN} \geq 0.1 \mu\text{F}$ should be used to prevent oscillations.
4. The internal phase compensation guarantees the IXD1701 stable operations even without load capacitor C_L . However, load capacitor $C_L = 0.1 - 1.0 \mu\text{F}$ located as close to V_{OUT} and V_{SS} pins may improve regulator's dynamic characteristics, reducing over/undershoot at heavy load.
5. In case of high output current, increasing the input capacitor value can stabilize operations.
6. Please ensure that output current I_{OUT} is less than $P_D / (V_{IN} - V_{OUT})$, where P_D is a rated power dissipation value of the package shown at ABSOLUTE MAXIMUM RATING table to not exceed it.
7. If IC is operates at high temperature with no load, the output voltage may increase beyond nominal range.

TEST CIRCUITS

Circuit ①

IXD1701B

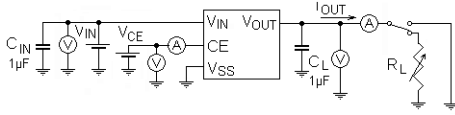

IXD1701D

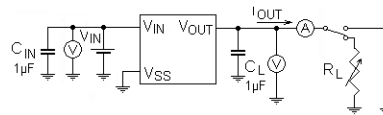

Circuit ②

IXD1701B

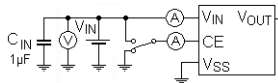

IXD1701D

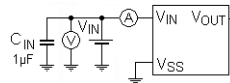

Circuit ③

IXD1701B

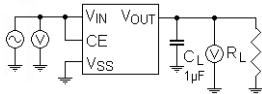

IXD1701D

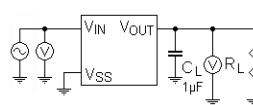

Unless otherwise stated, $T_a = 25^\circ\text{C}$, $V_{CE} = V_{IN}$, $C_{IN} = C_L = 1 \mu\text{F}$ (ceramic)
The IXD1701D has CE pin connected to V_{IN} internally.

TYPICAL PERFORMANCE CHARACTERISTICS

(1) Output Voltage vs. Output Current

IXD1701x182xx

$V_{IN} = V_{CE} = 4.8 \text{ V}$

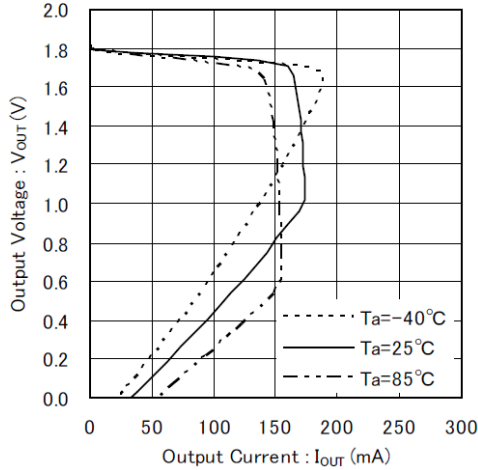

IXD1701x182xx

$V_{IN} = V_{CE} = 4.8 \text{ V}$, $T_a = 25^\circ\text{C}$

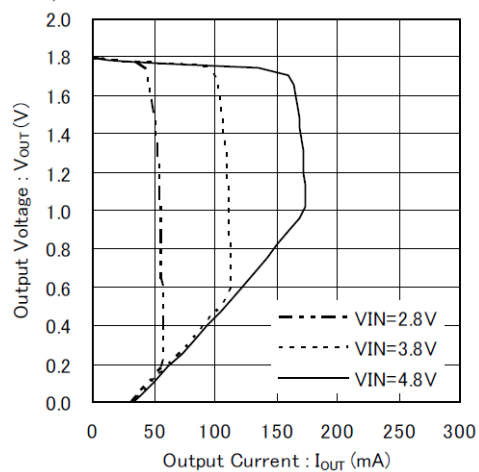

TYPICAL PERFORMANCE CHARACTERISTICS (Continued)

(1) Output Voltage vs Output Current (Continue)

Topr = 25 °C

IXD1701x502xx

V_{IN} = V_{CE} = 8.0 V

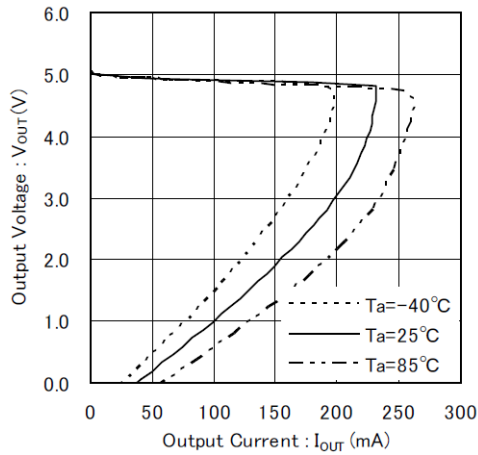

IXD1701x502xx

V_{IN} = V_{CE} = 8.0 V, Ta = 25°C

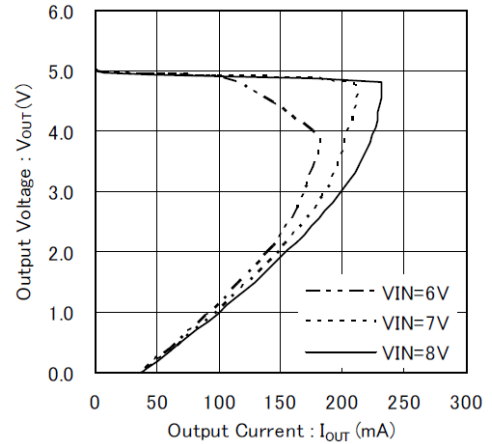

IXD1701xC02xx

V_{IN} = V_{CE} = 15.0 V

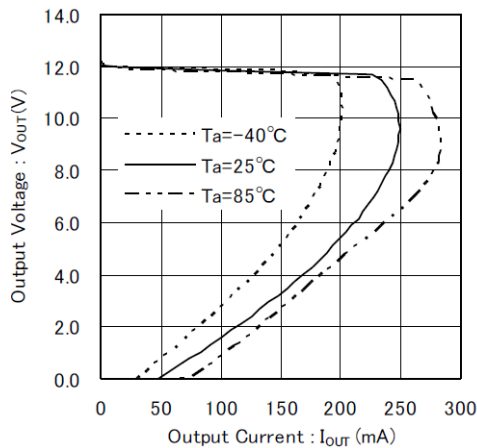

IXD1701xC02xx

V_{IN} = V_{CE} = 15.0 V, Ta = 25°C

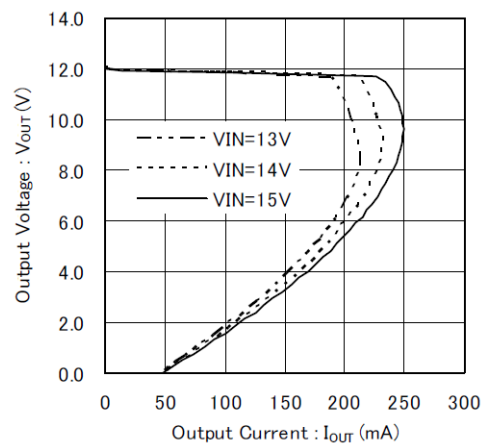

IXD1701xJ02xx

V_{IN} = V_{CE} = 21.0 V

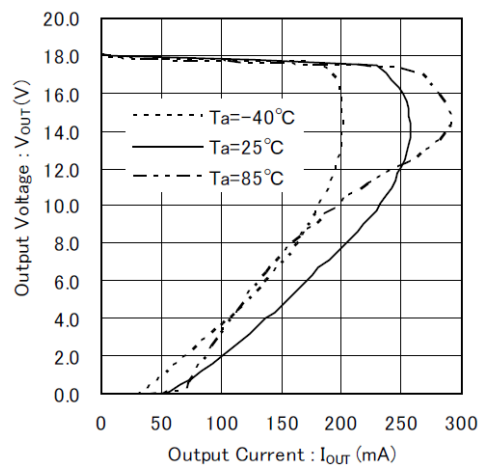

IXD1701xJ02xx

V_{IN} = V_{CE} = 21.0 V, Ta = 25°C

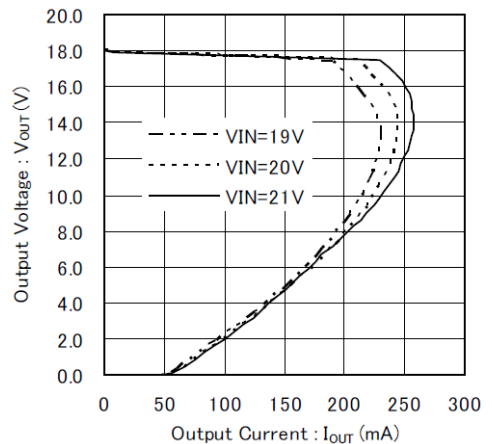

TYPICAL PERFORMANCE CHARACTERISTICS (Continued)

(2) Output Voltage vs. Input Voltage

IXD1701x182xx
 $V_{IN} = V_{CE}, T_a = 25^\circ\text{C}$

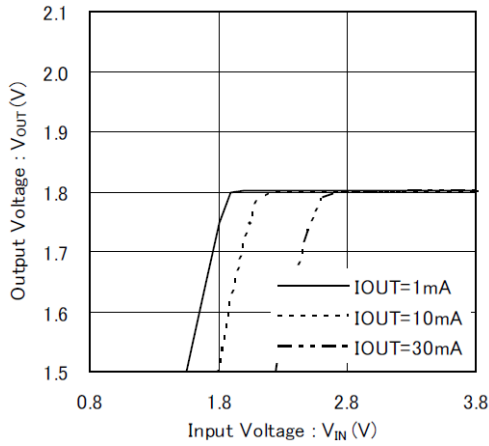

IXD1701x182xx
 $V_{IN} = V_{CE}, T_a = 25^\circ\text{C}$

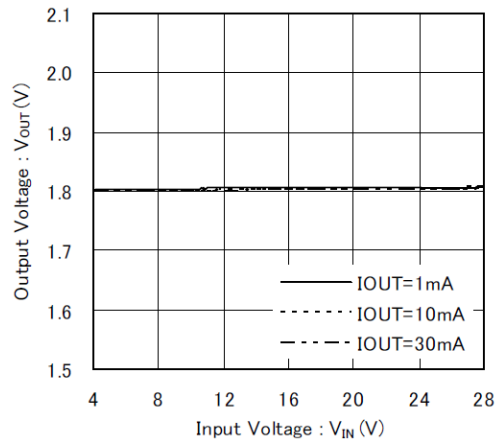

IXD1701x502xx
 $V_{IN} = V_{CE}, T_a = 25^\circ\text{C}$

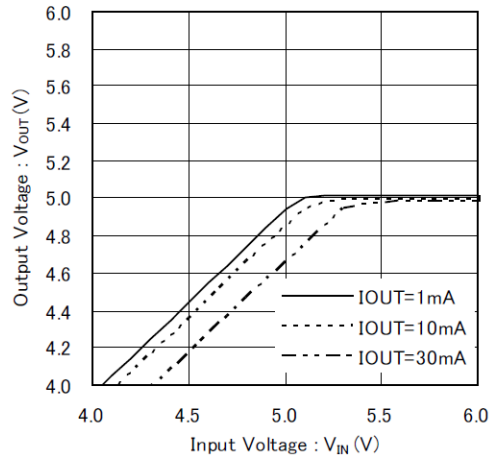

IXD1701x502xx
 $V_{IN} = V_{CE}, T_a = 25^\circ\text{C}$

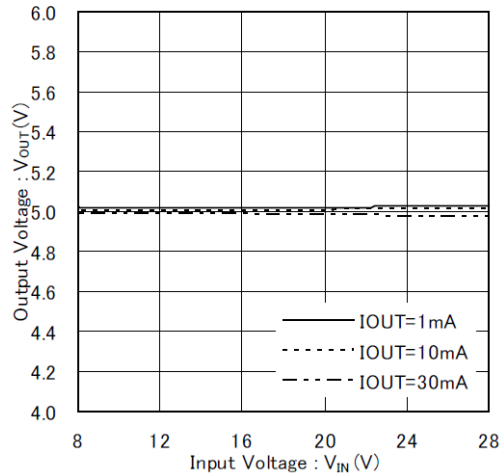

IXD1701xC02xx
 $V_{IN} = V_{CE}, T_a = 25^\circ\text{C}$

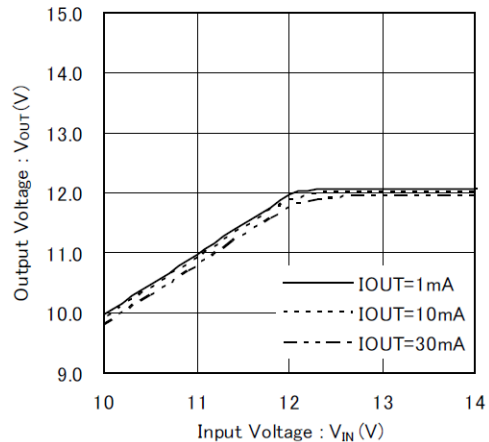

IXD1701xC02xx
 $V_{IN} = V_{CE}, T_a = 25^\circ\text{C}$

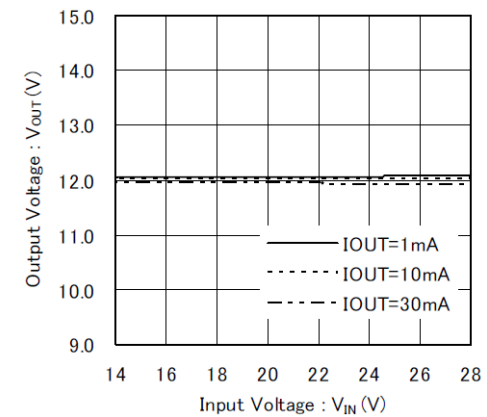

TYPICAL PERFORMANCE CHARACTERISTICS (Continued)

(2) Output Voltage vs. Input Voltage

IXD1701xJ02xx
 $V_{IN} = V_{CE}$, $T_a = 25^\circ\text{C}$

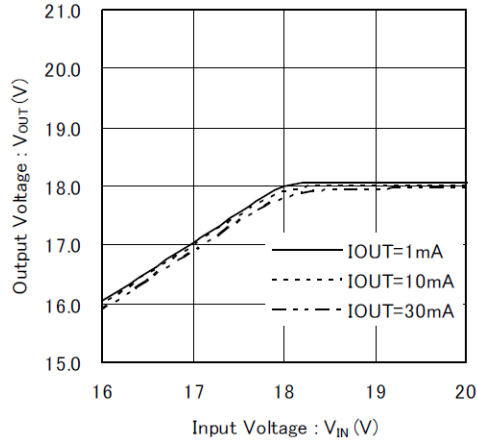

IXD1701xJ02xx
 $V_{IN} = V_{CE}$, $T_a = 25^\circ\text{C}$

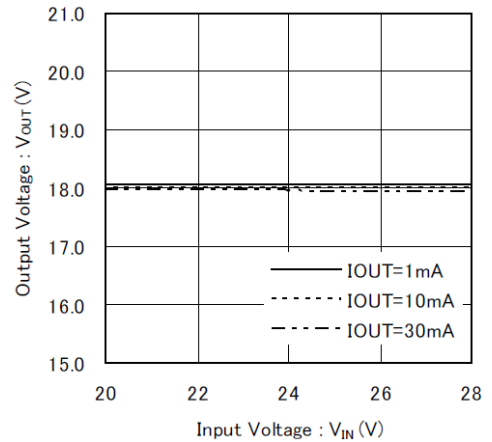

(3) Dropout Voltage vs. Output Current

IXD1701x182xx
 $V_{IN} = V_{CE}$

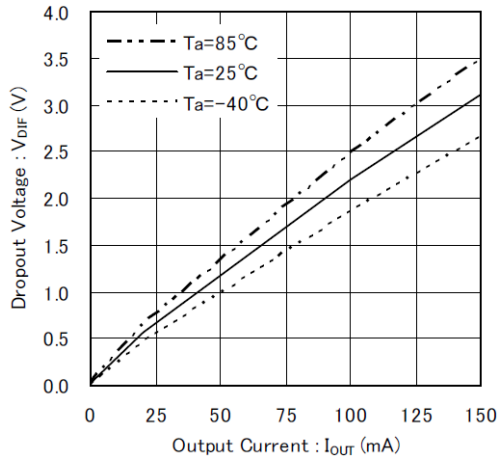

IXD1701x502xx
 $V_{IN} = V_{CE}$

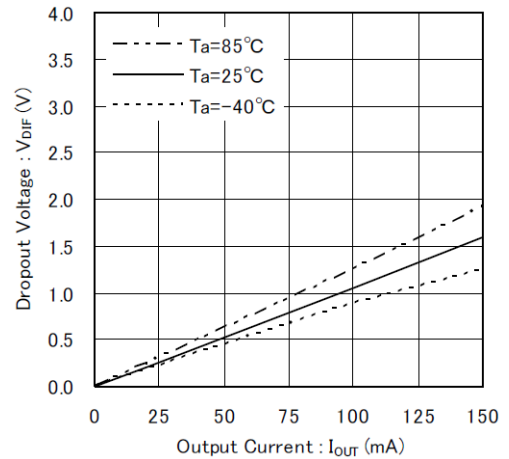

IXD1701xC02xx
 $V_{IN} = V_{CE}$

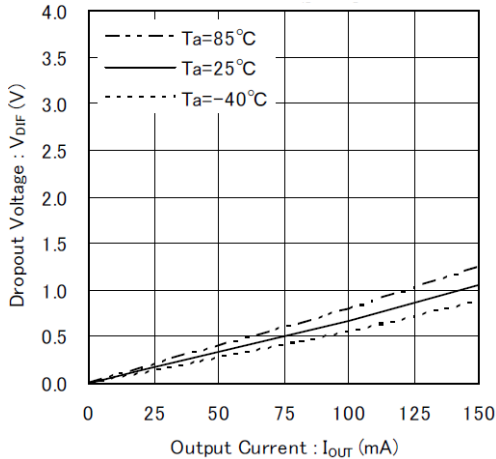

IXD1701xJ02xx
 $V_{IN} = V_{CE}$

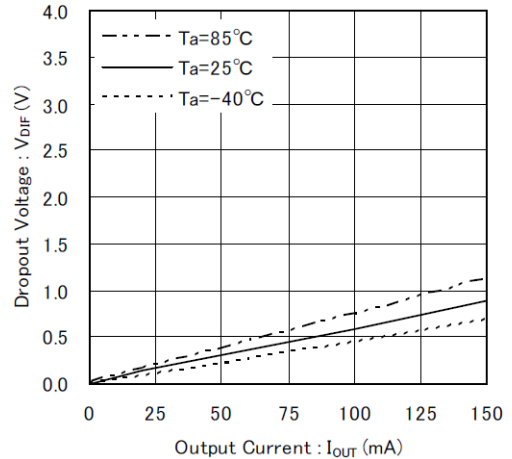

TYPICAL PERFORMANCE CHARACTERISTICS (Continued)

(4) Supply Current vs. Input Voltage

IXD1701x182xx

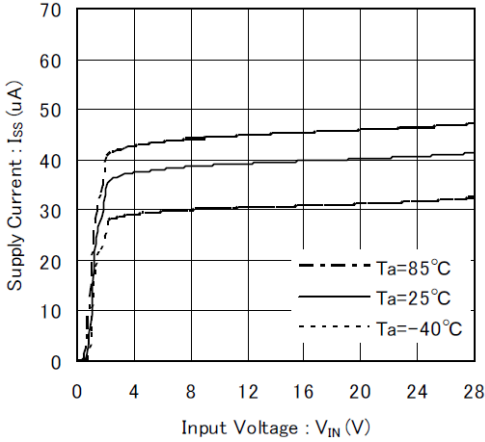

IXD1701x502xx

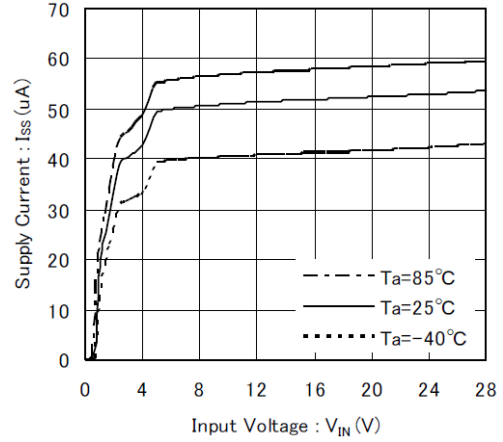

IXD1701xC02xx

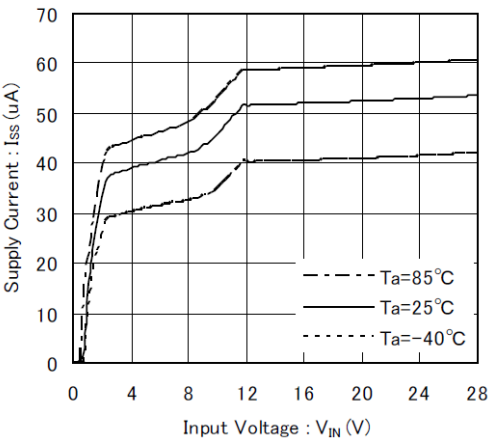

IXD1701xJ02xx

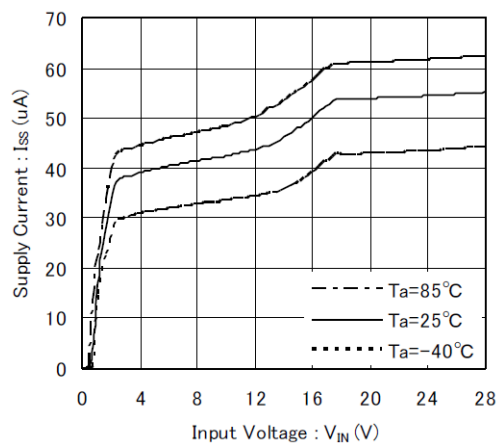

(5) Supply Current vs. Ambient temperature

IXD1701x182xx

$V_{IN} = V_{CE} = 3.8 V$

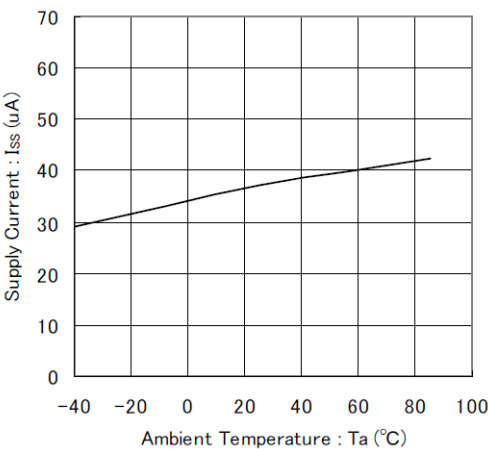

IXD1701x502xx

$V_{IN} = V_{CE} = 7.0 V$

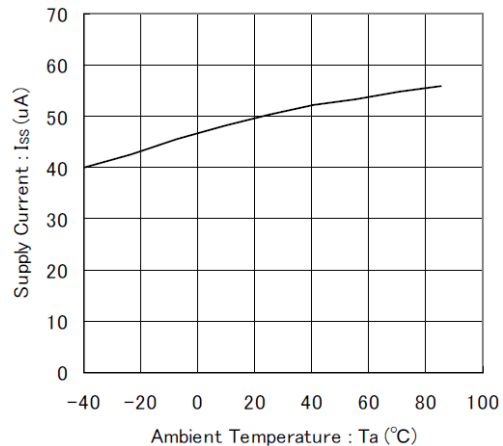

TYPICAL PERFORMANCE CHARACTERISTICS (Continued)

(5) Supply Current vs. Ambient temperature (Continued)

IXD1701xC02xx
 $V_{IN} = V_{CE} = 14.0\text{ V}$

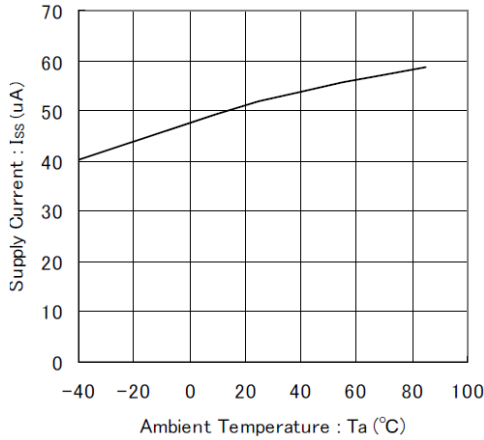

IXD1701xJ502xx
 $V_{IN} = V_{CE} = 20.0\text{ V}$

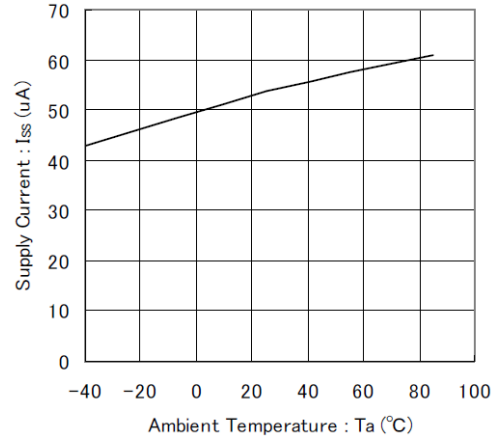

(6) Output Voltage vs. Ambient temperature (Continued)

IXD1701x182xx
 $V_{IN} = V_{CE}$

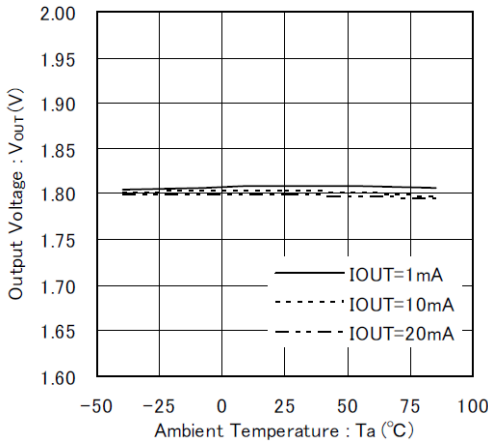

IXD1701x502xx
 $V_{IN} = V_{CE}$

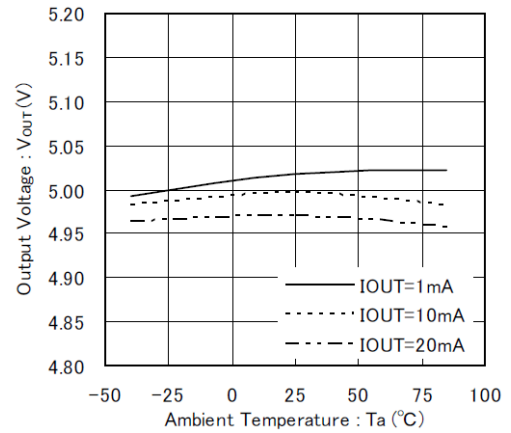

IXD1701xC02xx
 $V_{IN} = V_{CE}$

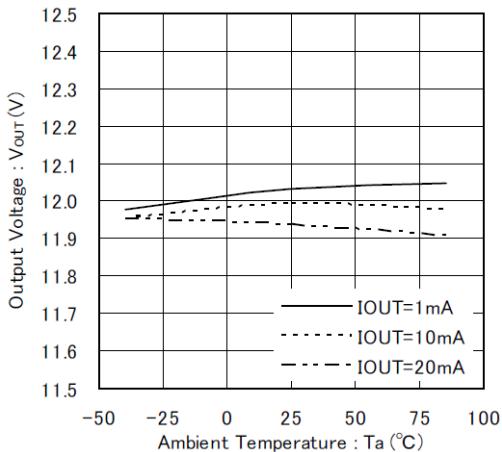

IXD1701xJ02xx
 $V_{IN} = V_{CE}$

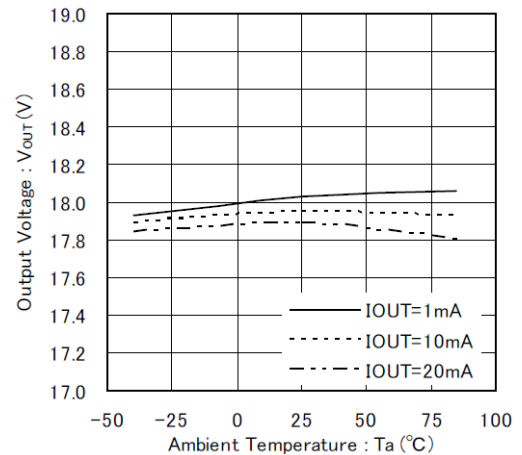

TYPICAL PERFORMANCE CHARACTERISTICS (Continued)

(7) Input Voltage Transient Response

IXD1701x332xx

$I_{OUT} = 1\text{ mA}$, $T_a = 25^\circ\text{C}$, $t_R = t_F = 5\ \mu\text{s}$, $V_{IN} = 5.3\text{ V} \leftrightarrow 6.3\text{ V}$

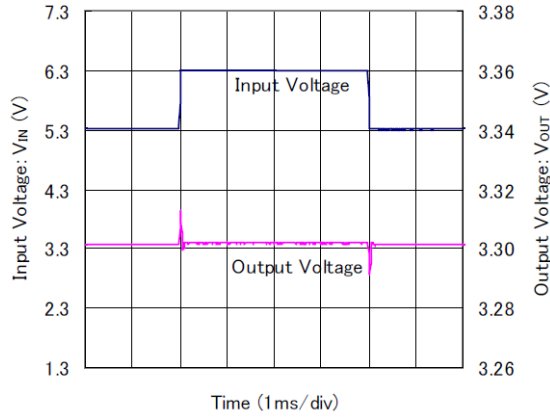

IXD1701x332xx

$I_{OUT} = 30\text{ mA}$, $T_a = 25^\circ\text{C}$, $t_R = t_F = 5\ \mu\text{s}$, $V_{IN} = 5.3\text{ V} \leftrightarrow 6.3\text{ V}$

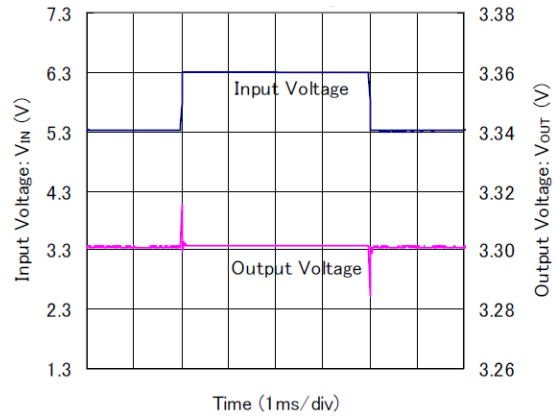

IXD1701x502xx

$I_{OUT} = 1\text{ mA}$, $T_a = 25^\circ\text{C}$, $t_R = t_F = 5\ \mu\text{s}$, $V_{IN} = 7.0\text{ V} \leftrightarrow 8.0\text{ V}$

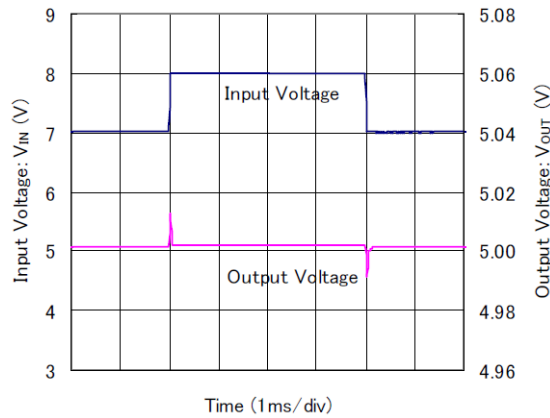

IXD1701x502xx

$I_{OUT} = 30\text{ mA}$, $T_a = 25^\circ\text{C}$, $t_R = t_F = 5\ \mu\text{s}$, $V_{IN} = 7.0\text{ V} \leftrightarrow 8.0\text{ V}$

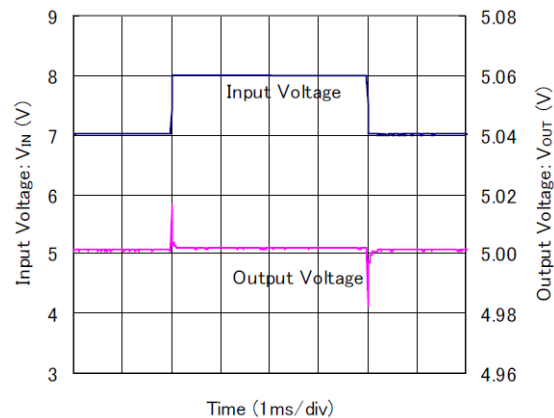

IXD1701xC02xx

$I_{OUT} = 1\text{ mA}$, $T_a = 25^\circ\text{C}$, $t_R = t_F = 5\ \mu\text{s}$, $V_{IN} = 14.0\text{ V} \leftrightarrow 15.0\text{ V}$

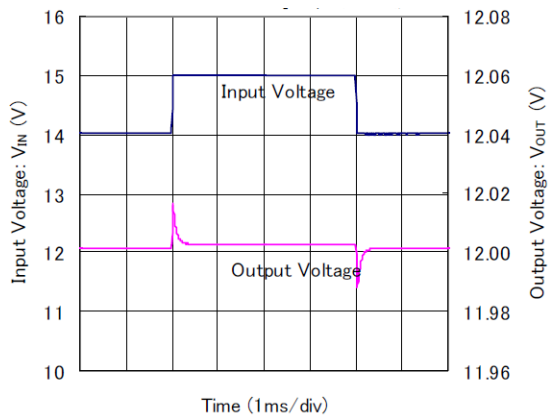

IXD1701xC02xx

$I_{OUT} = 30\text{ mA}$, $T_a = 25^\circ\text{C}$, $t_R = t_F = 5\ \mu\text{s}$, $V_{IN} = 14.0\text{ V} \leftrightarrow 15.0\text{ V}$

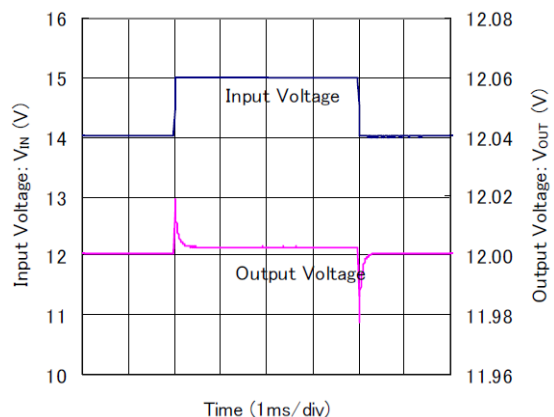

TYPICAL PERFORMANCE CHARACTERISTICS (Continued)

(7) Input Voltage Transient Response (Continued)

IXD1701xJ02xx

$I_{OUT} = 30\text{ mA}$, $T_a = 25^\circ\text{C}$, $t_R = t_F = 5\ \mu\text{s}$, $V_{IN} = 20.0\text{ V} \leftrightarrow 21.9\text{ V}$

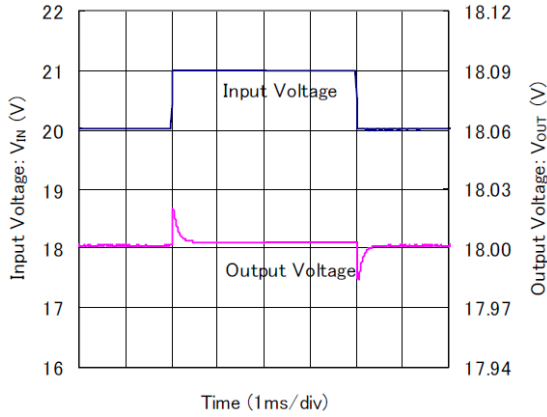

IXD1701xJ02xx

$I_{OUT} = 30\text{ mA}$, $T_a = 25^\circ\text{C}$, $t_R = t_F = 5\ \mu\text{s}$, $V_{IN} = 20.03\text{ V} \leftrightarrow 21.0\text{ V}$

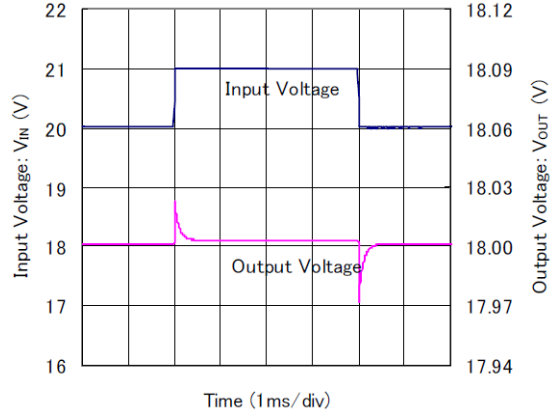

(8) Load Transient Response

IXD1701x332xx

$T_a = 25^\circ\text{C}$, $t_R = t_F = 5\ \mu\text{s}$, $V_{IN} = 5.3\text{ V}$, $I_{OUT} = 1\text{ mA} \leftrightarrow 30\text{ mA}$

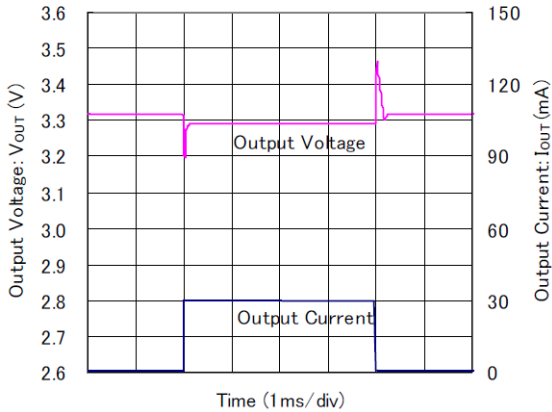

IXD1701x502xx

$T_a = 25^\circ\text{C}$, $t_R = t_F = 5\ \mu\text{s}$, $V_{IN} = 7.0\text{ V}$, $I_{OUT} = 1\text{ mA} \leftrightarrow 30\text{ mA}$

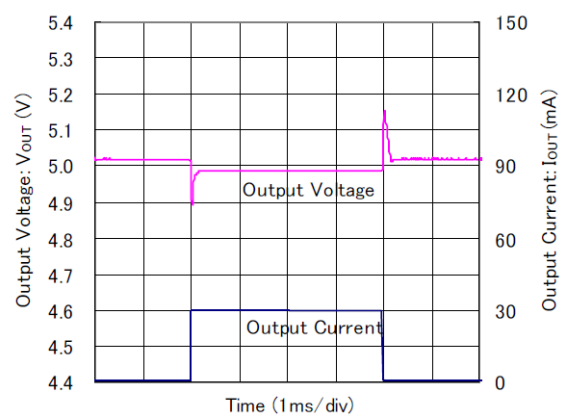

IXD1701xJ02xx

$T_a = 25^\circ\text{C}$, $t_R = t_F = 5\ \mu\text{s}$, $V_{IN} = 14.0\text{ V}$, $I_{OUT} = 1\text{ mA} \leftrightarrow 30\text{ mA}$

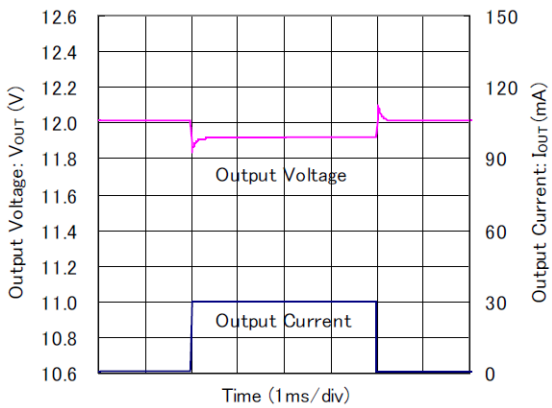

IXD1701xJ02xx

$T_a = 25^\circ\text{C}$, $t_R = t_F = 5\ \mu\text{s}$, $V_{IN} = 20.0\text{ V}$, $I_{OUT} = 1\text{ mA} \leftrightarrow 30\text{ mA}$

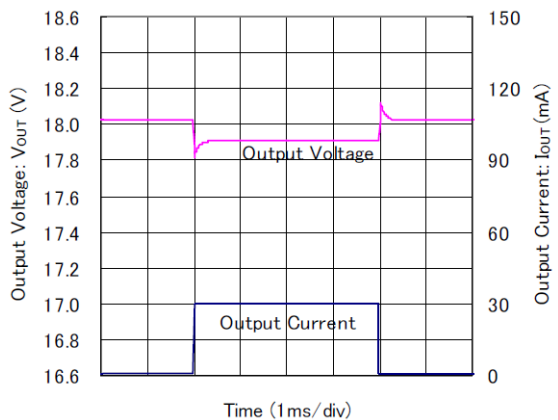

TYPICAL PERFORMANCE CHARACTERISTICS (Continued)

(9) Input Voltage Rising Response Time

IXD1701x332xx

$T_a = 25^\circ\text{C}$, $t_{\text{R}} = 5 \mu\text{s}$, $V_{\text{IN}} = 0 \rightarrow 5.3 \text{ V}$ $I_{\text{OUT}} = 1 \text{ mA}$,

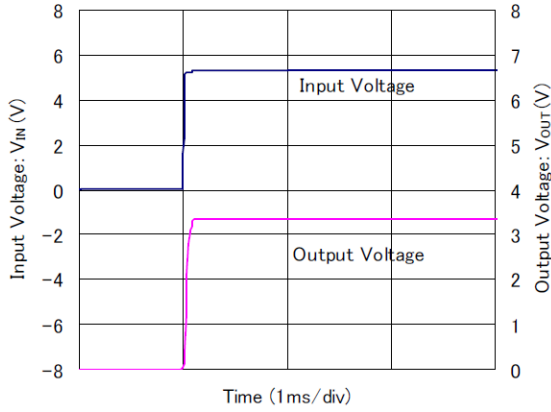

IXD1701x332xx

$T_a = 25^\circ\text{C}$, $t_{\text{R}} = 5 \mu\text{s}$, $V_{\text{IN}} = 0 \rightarrow 5.3 \text{ V}$ $I_{\text{OUT}} = 30 \text{ mA}$

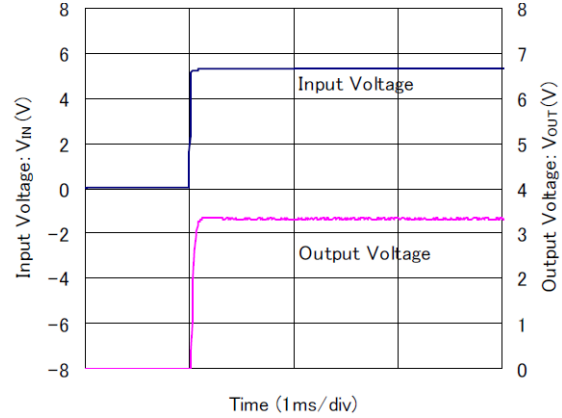

IXD1701x502xx

$T_a = 25^\circ\text{C}$, $t_{\text{R}} = 5 \mu\text{s}$, $V_{\text{IN}} = 0 \rightarrow 7.0 \text{ V}$ $I_{\text{OUT}} = 1 \text{ mA}$,

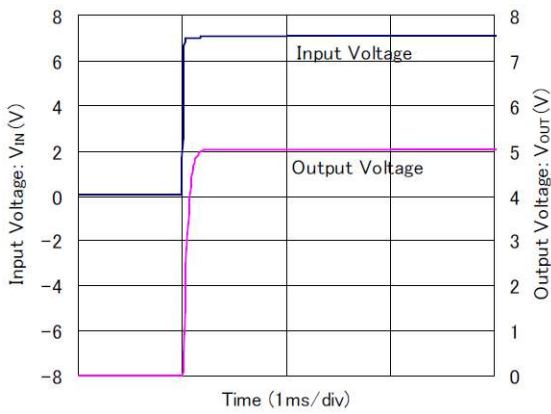

IXD1701x502xx

$T_a = 25^\circ\text{C}$, $t_{\text{R}} = 5 \mu\text{s}$, $V_{\text{IN}} = 0 \rightarrow 7.0 \text{ V}$ $I_{\text{OUT}} = 30 \text{ mA}$

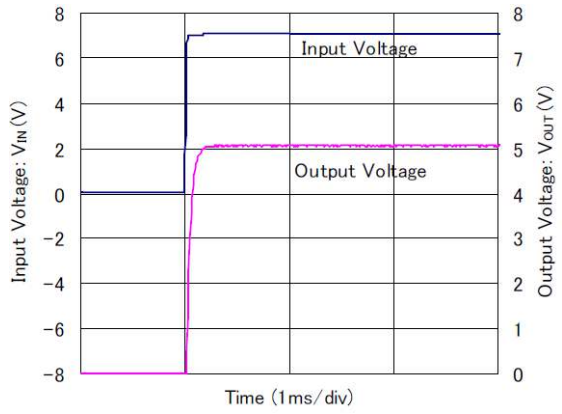

IXD1701xC02xx

$T_a = 25^\circ\text{C}$, $t_{\text{R}} = 5 \mu\text{s}$, $V_{\text{IN}} = 0 \rightarrow 14.0 \text{ V}$ $I_{\text{OUT}} = 1 \text{ mA}$,

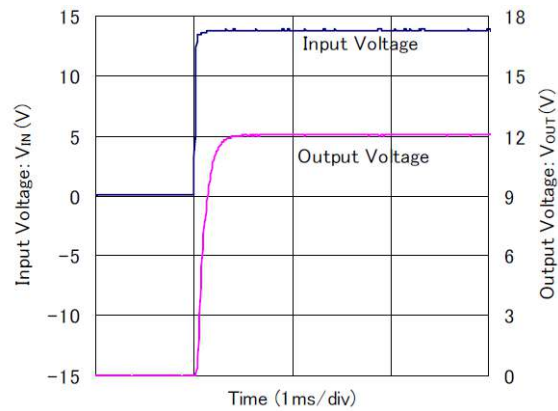

IXD1701xC02xx

$T_a = 25^\circ\text{C}$, $t_{\text{R}} = 5 \mu\text{s}$, $V_{\text{IN}} = 0 \rightarrow 14.0 \text{ V}$ $I_{\text{OUT}} = 30 \text{ mA}$

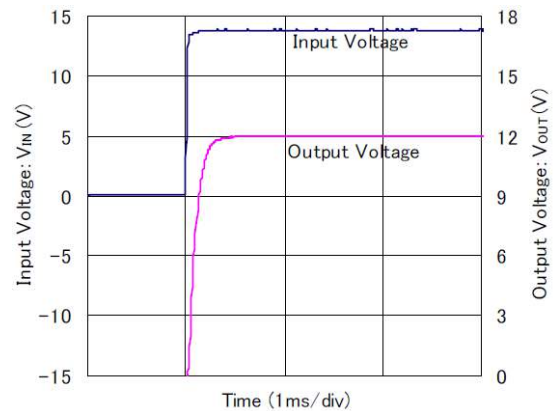

TYPICAL PERFORMANCE CHARACTERISTICS (Continued)

(9) Input Voltage Rising Response Time (Continued)

IXD1701xJ02xx

$T_a = 25^\circ\text{C}$, $t_r = 5 \mu\text{s}$, $V_{IN} = 0 \rightarrow 20.0 \text{ V}$, $I_{OUT} = 1 \text{ mA}$,

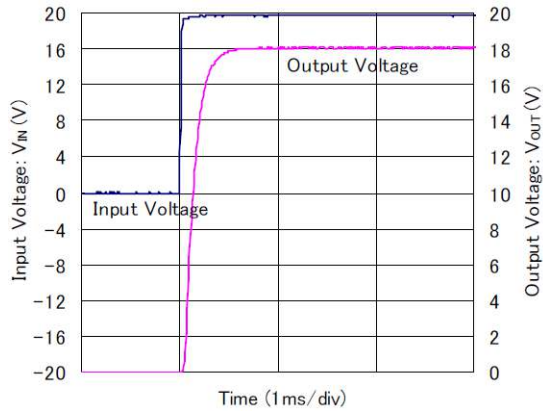

IXD1701xJ02xx

$T_a = 25^\circ\text{C}$, $t_r = 5 \mu\text{s}$, $V_{IN} = 0 \rightarrow 20.0 \text{ V}$, $I_{OUT} = 30 \text{ mA}$

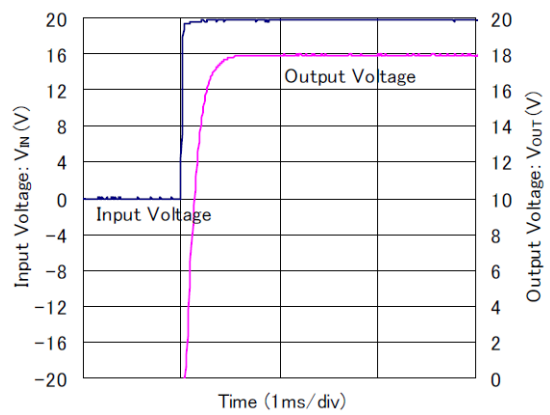

(10) CE Rising Response Time

IXD1701x332xx

$T_a = 25^\circ\text{C}$, $t_r = 5 \mu\text{s}$, $V_{IN} = 5.3 \text{ V}$, $V_{CE} = 0 \rightarrow V_{IN}$, $I_{OUT} = 1 \text{ mA}$,

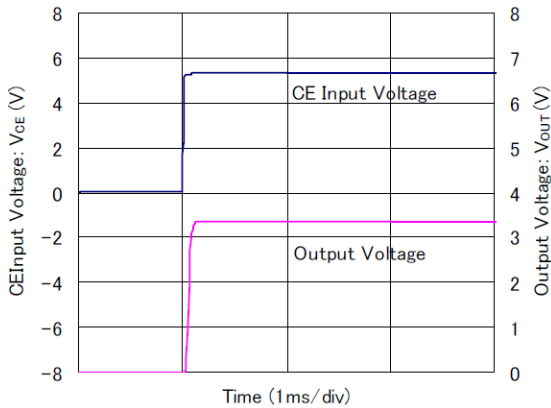

IXD1701x332xx

$T_a = 25^\circ\text{C}$, $t_r = 5 \mu\text{s}$, $V_{IN} = 5.3 \text{ V}$, $V_{CE} = 0 \rightarrow V_{IN}$, $I_{OUT} = 30 \text{ mA}$

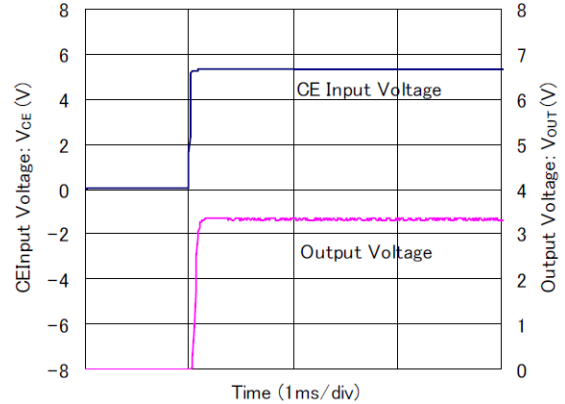

IXD1701x502xx

$T_a = 25^\circ\text{C}$, $t_r = 5 \mu\text{s}$, $V_{IN} = 7.0 \text{ V}$, $V_{CE} = 0 \rightarrow V_{IN}$, $I_{OUT} = 1 \text{ mA}$,

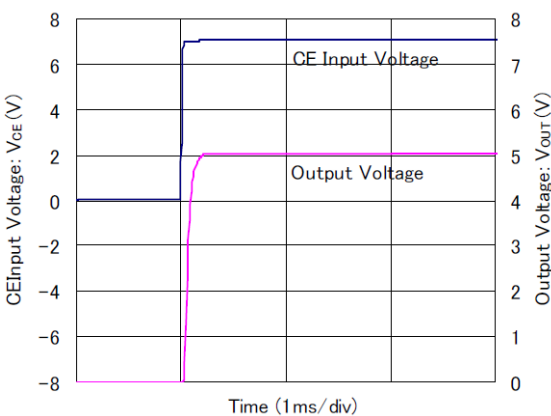

IXD1701x502xx

$T_a = 25^\circ\text{C}$, $t_r = 5 \mu\text{s}$, $V_{IN} = 7.0 \text{ V}$, $V_{CE} = 0 \rightarrow V_{IN}$, $I_{OUT} = 30 \text{ mA}$

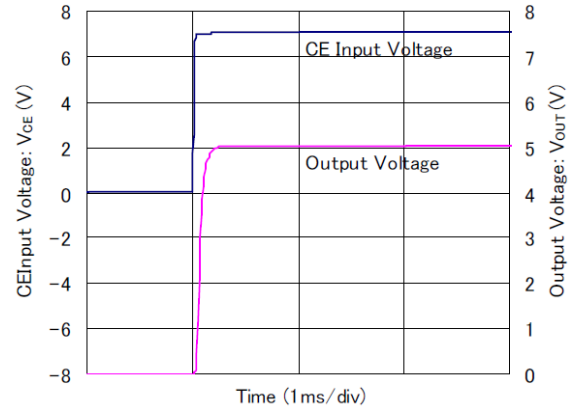

TYPICAL PERFORMANCE CHARACTERISTICS (Continued)

(10) CE Rising Response Time (Continued)

IXD1701xC02xx

$T_a = 25^\circ\text{C}$, $t_{r} = 5 \mu\text{s}$, $V_{IN} = 14.0 \text{ V}$, $V_{CE} = 0 \rightarrow V_{IN}$, $I_{OUT} = 1 \text{ mA}$,

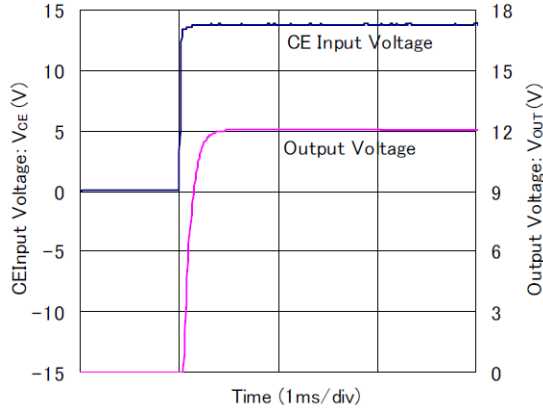

IXD1701xC02xx

$T_a = 25^\circ\text{C}$, $t_{r} = 5 \mu\text{s}$, $V_{IN} = 14.0 \text{ V}$, $V_{CE} = 0 \rightarrow V_{IN}$, $I_{OUT} = 30 \text{ mA}$

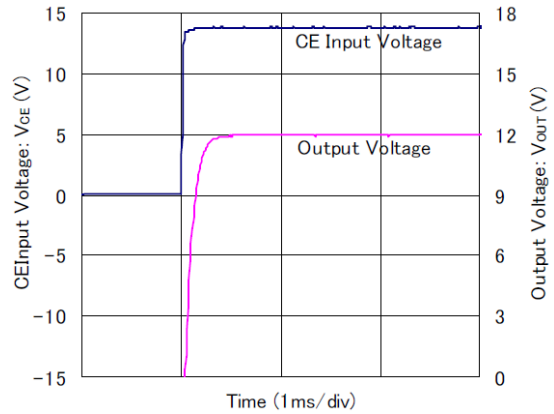

IXD1701xJ02xx

$T_a = 25^\circ\text{C}$, $t_{r} = 5 \mu\text{s}$, $V_{IN} = 20.0 \text{ V}$, $V_{CE} = 0 \rightarrow V_{IN}$, $I_{OUT} = 1 \text{ mA}$,

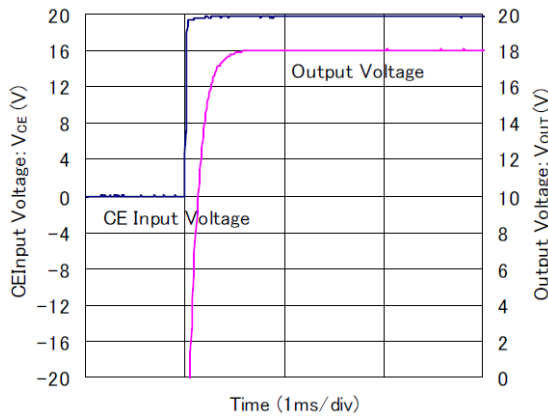

IXD1701xJ02xx

$T_a = 25^\circ\text{C}$, $t_{r} = 5 \mu\text{s}$, $V_{IN} = 20.0 \text{ V}$, $V_{CE} = 0 \rightarrow V_{IN}$, $I_{OUT} = 30 \text{ mA}$

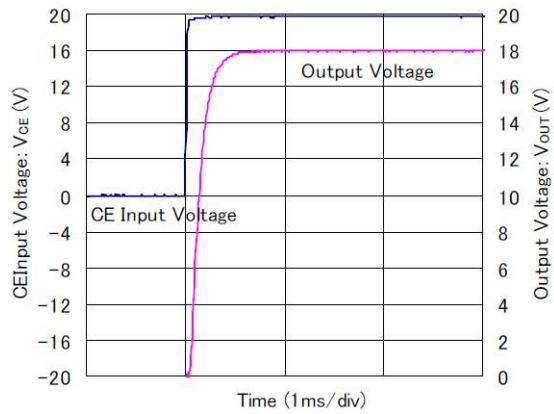

(11) Power Supply Ripple Rejection

IXD1701x332xx

$T_a = 25^\circ\text{C}$, $V_{IN} = V_{CE} = 5.3 \text{ V} + 0.5 \text{ V}_{p-pAC}$, $I_{OUT} = 1 \text{ mA}$,

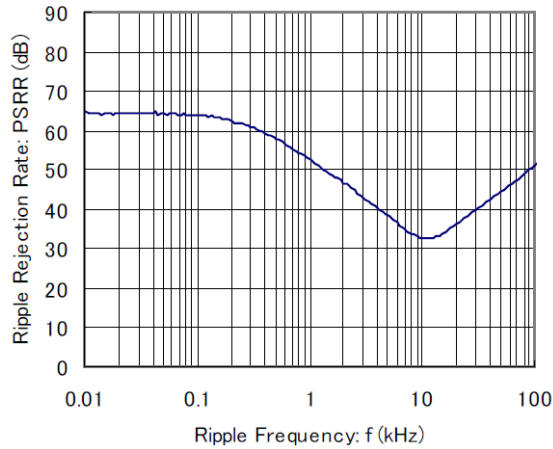

IXD1701x332xx

$T_a = 25^\circ\text{C}$, $V_{IN} = V_{CE} = 5.3 \text{ V} + 0.5 \text{ V}_{p-pAC}$, $I_{OUT} = 30 \text{ mA}$,

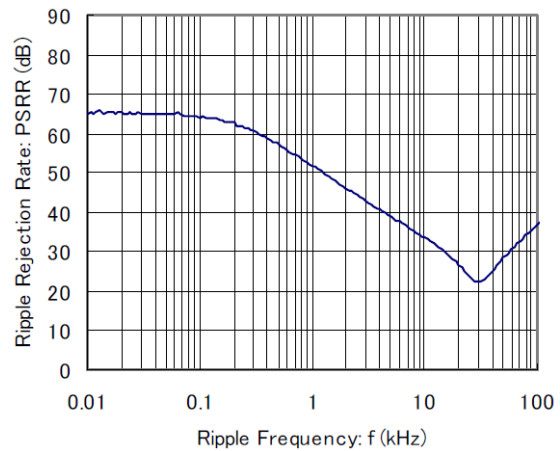

TYPICAL PERFORMANCE CHARACTERISTICS (Continued)

(11) Power Supply Ripple Rejection (Continued)

IXD1701x502xx

$T_a = 25^\circ\text{C}$, $V_{IN} = V_{CE} = 7.0\text{ V} + 0.5\text{ Vp-p}_{AC}$, $I_{OUT} = 1\text{ mA}$,

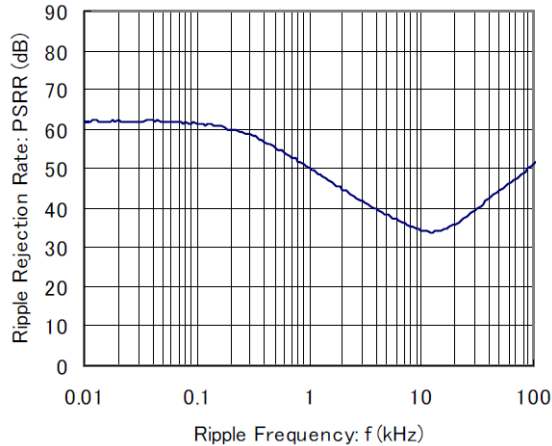

IXD1701x502xx

$T_a = 25^\circ\text{C}$, $V_{IN} = V_{CE} = 7.0\text{ V} + 0.5\text{ Vp-p}_{AC}$, $I_{OUT} = 30\text{ mA}$,

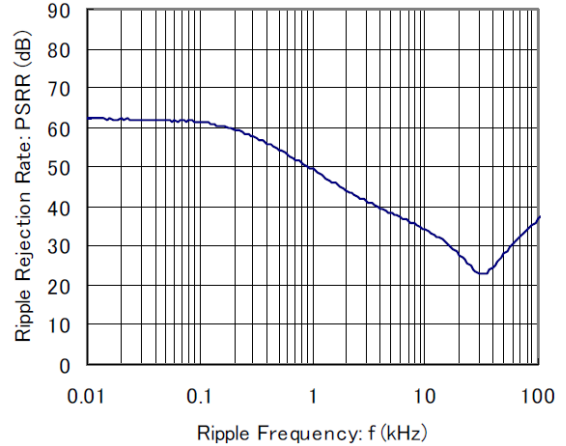

IXD1701xC02xx

$T_a = 25^\circ\text{C}$, $V_{IN} = V_{CE} = 14.0\text{ V} + 0.5\text{ Vp-p}_{AC}$, $I_{OUT} = 1\text{ mA}$,

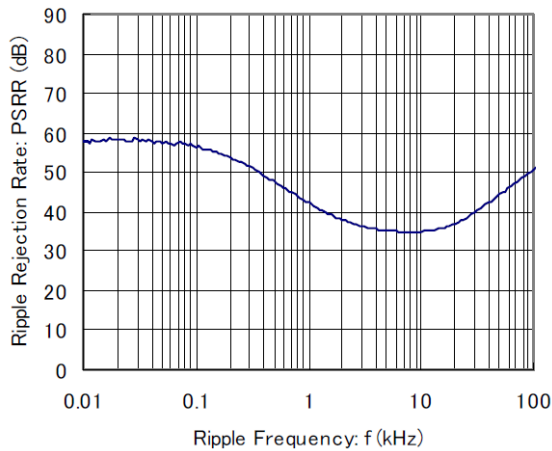

IXD1701xC02xx

$T_a = 25^\circ\text{C}$, $V_{IN} = V_{CE} = 14.0\text{ V} + 0.5\text{ Vp-p}_{AC}$, $I_{OUT} = 30\text{ mA}$,

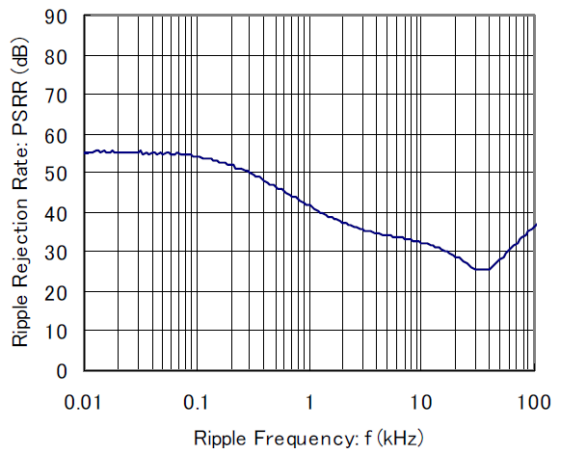

IXD1701xJ02xx

$T_a = 25^\circ\text{C}$, $V_{IN} = V_{CE} = 20.0\text{ V} + 0.5\text{ Vp-p}_{AC}$, $I_{OUT} = 1\text{ mA}$,

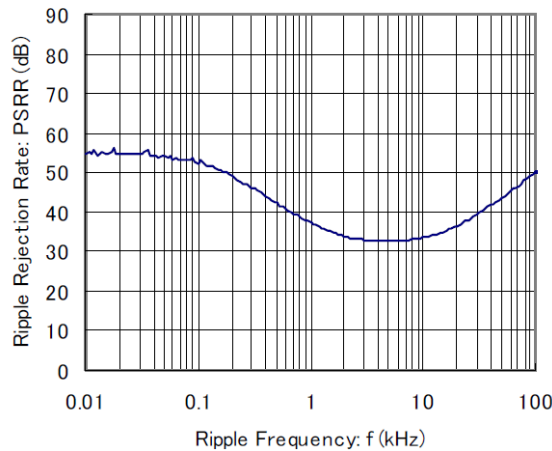

IXD1701xJ02xx

$T_a = 25^\circ\text{C}$, $V_{IN} = V_{CE} = 20.0\text{ V} + 0.5\text{ Vp-p}_{AC}$, $I_{OUT} = 30\text{ mA}$,

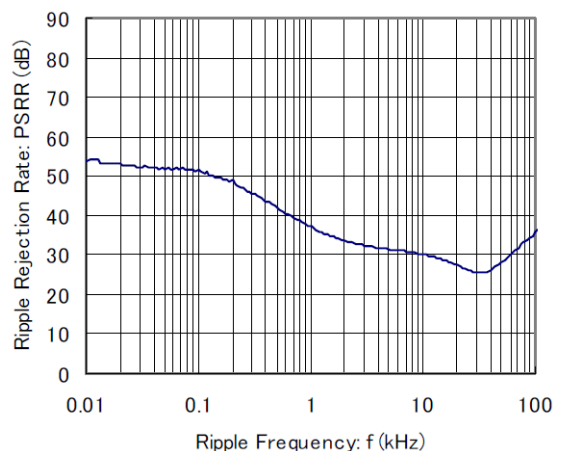

ORDERING INFORMATION

IXD1701B①②③④⑤-⑥ CE function

IXD1701D①②③④⑤-⑥ No CE function (3-pin regulator)

DESIGNATOR	DESCRIPTION	SYMBOL	DESCRIPTION
①②	Output Voltage	18 – 99	For voltages from 1.8 V to 9.9 V, e.g. 2.5 V - ① = 2, ② = 5; 5.0 V - ① = 5, ② = 0
		A0 – J0	For voltages from 10.0 V to 18.0 V, e.g. 11.6 V - ① = B, ② = 6; 18.0 V - ① = J, ② = 0
③	¹⁾ Output Voltage Accuracy	2	Accuracy: ±2%
④⑤-⑥ (*)	Packages ¹⁾ (Order Limit)	MR	SOT-25 (3000/Reel)
		MR-G	SOT-25 (3000/Reel)
		PR	SOT-89, SOT-89-5 (1000/Reel)
		PR-G	SOT-89, SOT-89-5 (1000/Reel)
		ER	USP-6C (3000/Reel)
		ER-G	USP-6C (3000/Reel)
		FR	SOT-223 (1000/Reel)
		FR-G	SOT-223 (1000/Reel)
		JR	TO-252 (2500/reel)
		JR-G	TO-252 (2500/reel)

NOTE:

The “-G” suffix denotes Halogen and Antimony free as well as being fully RoHS compliant.

- IXD1701B version is available in SOT-25, SOT-89-5, and USP-6C packages only; IXD1701D version is available in SOT-89, SOT-223, and TO-252 packages only.

PACKAGE DRAWING AND DIMENSIONS

Units: mm

SOT-25

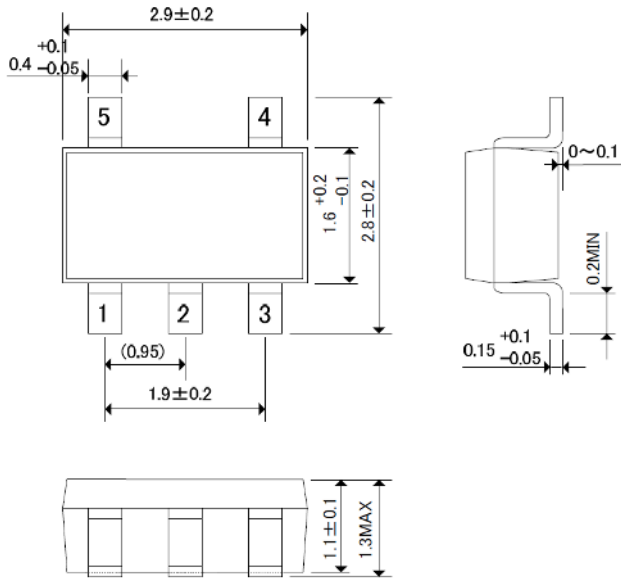

SOT-89

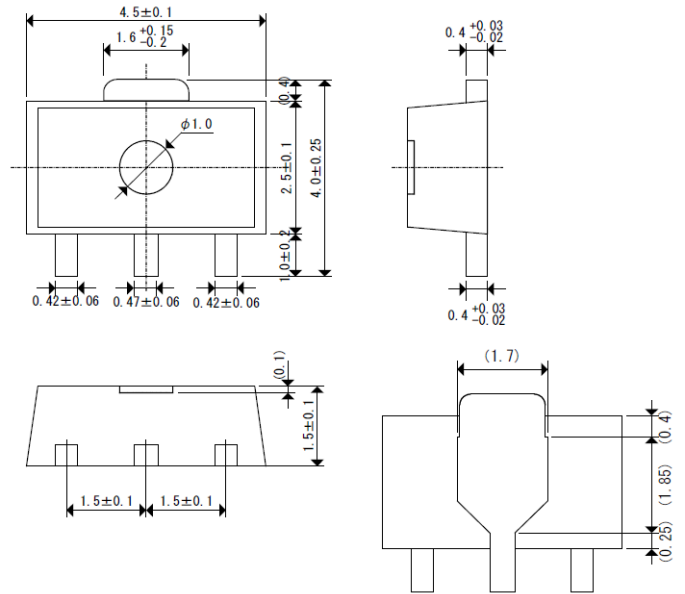

SOT-89-5

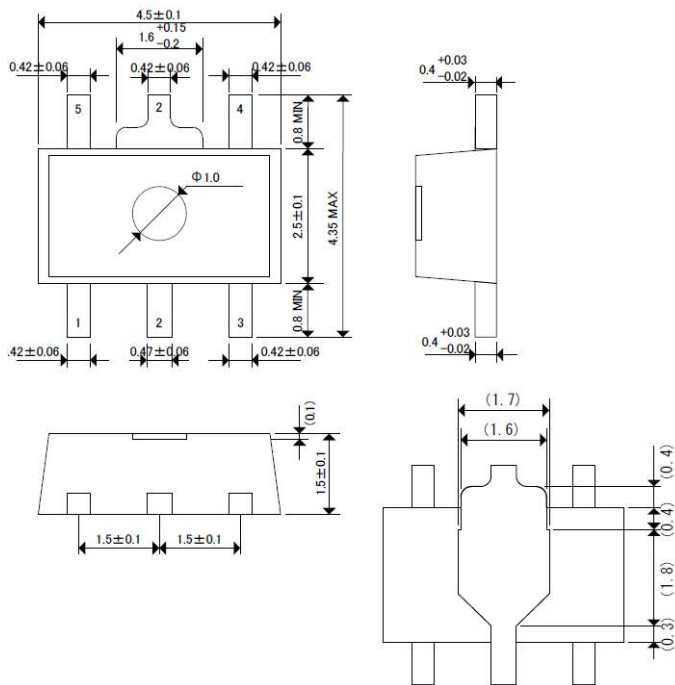

SOT-223

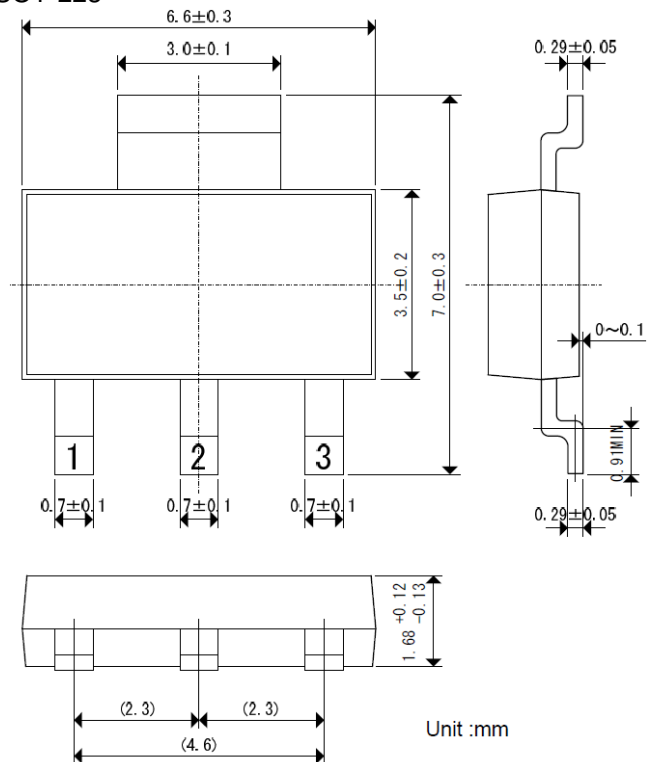

Unit: mm

PACKAGE DRAWING AND DIMENSIONS (CONTINUED)

Units: mm

TO-252

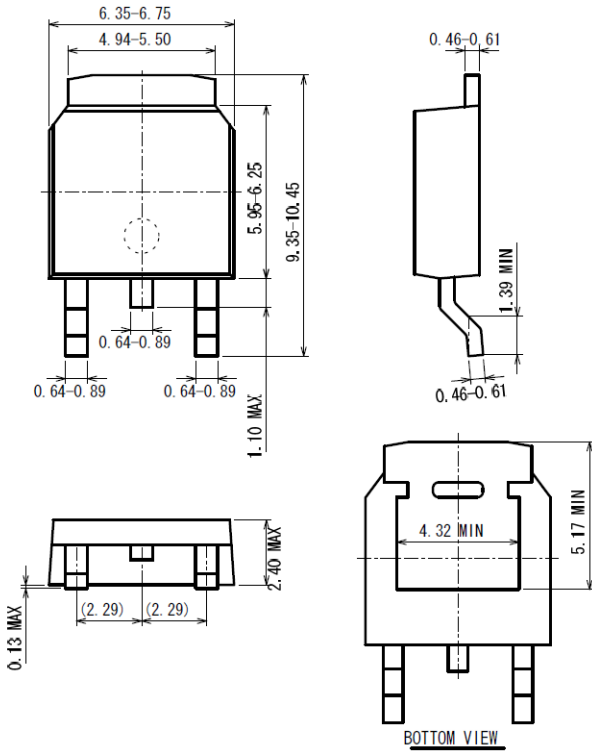

USP-6C

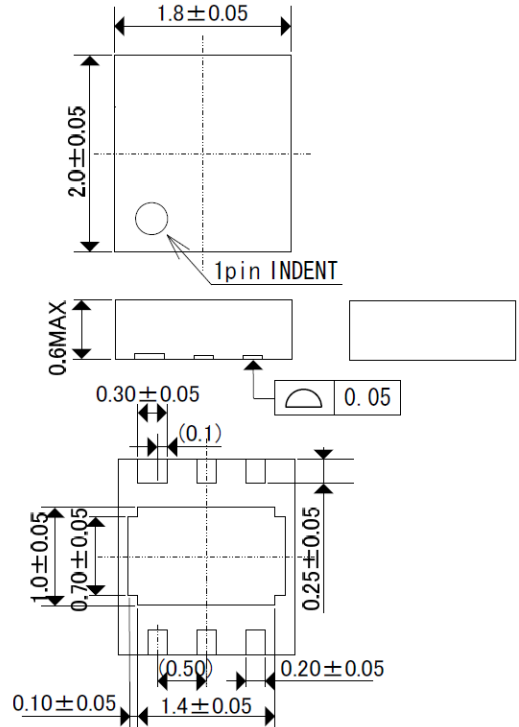

USP-6C Reference Pattern Layout

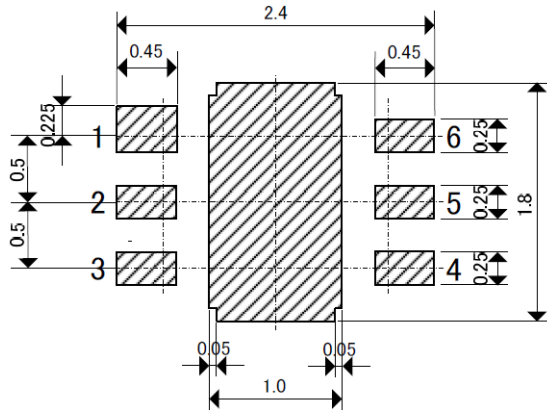

USP-6C Reference Metal Mask Design

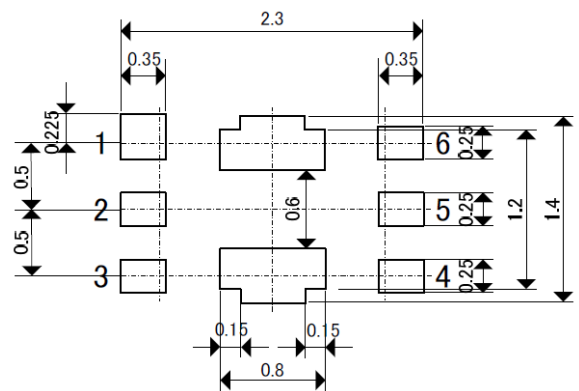

PACKAGE POWER DISSIPATION

SOT-25 Power Dissipation

The power dissipation varies with the mount board conditions. Please use this data as a reference only.

1. Measurement Conditions:

Condition:	Mount on a board
Ambient:	Natural convection
Soldering:	Lead (Pb) free
Board:	Dimensions 40x40 mm (1600 mm ² in one side) Copper (Cu) traces occupy 50% of the board area on top and bottom layers Package heat sink tied to the copper traces. (Board of SOT-26 is used)
Material:	Glass Epoxy (FR-4)
Thickness:	1.6 mm
Through-hole:	4 x 0.8 Diameter

2. Power Dissipation vs. Ambient Temperature

Board Mount ($T_{jmax} = 125\text{ }^{\circ}\text{C}$)

Ambient Temperature, $^{\circ}\text{C}$	Power Dissipation Pd, mW	Thermal Resistance, $^{\circ}\text{C}/\text{W}$
25	600	166.67
85	240	

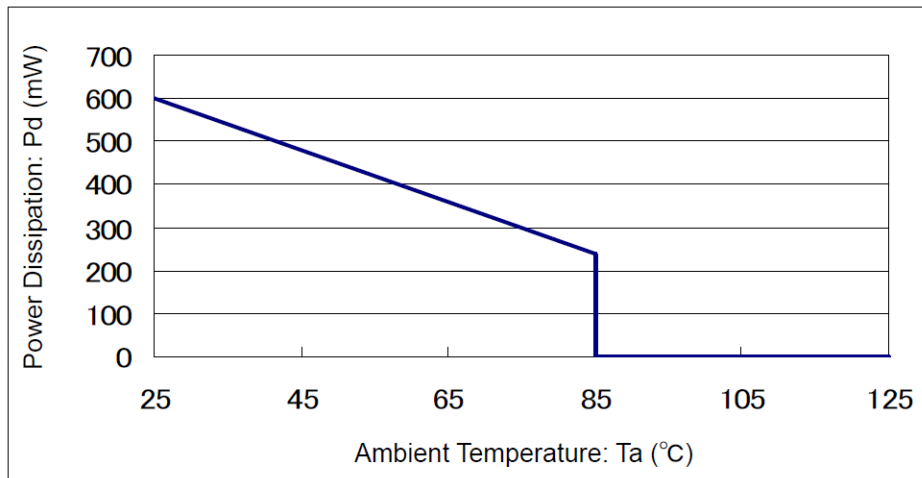
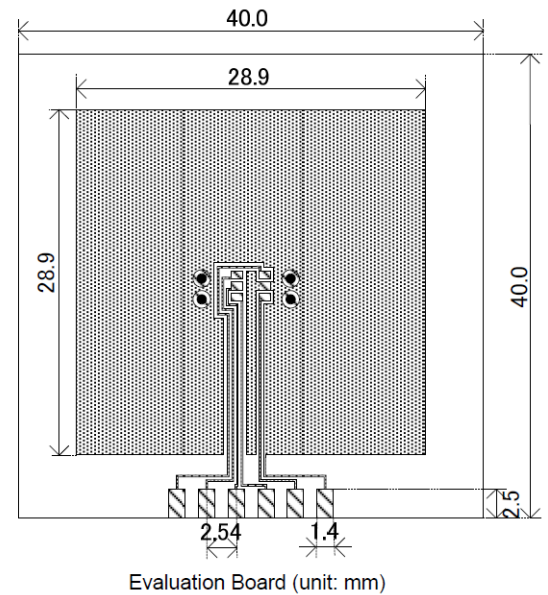

PACKAGE POWER DISSIPATION (CONTINUED)

SOT-89 Power Dissipation

The power dissipation varies with the mount board conditions. Please use this data as a reference only.

1. Measurement Conditions:

- Condition: Mount on a board
- Ambient: Natural convection
- Soldering: Lead (Pb) free
- Board: Dimensions 40x40 mm (1600 mm² in one side)
Copper (Cu) traces occupy 50% of the board area on top and bottom layers
Package heat sink tied to the copper traces.
- Material: Glass Epoxy (FR-4)
- Thickness: 1.6 mm
- Through-hole: 5 x 0.8 Diameter

2. Power Dissipation vs. Ambient Temperature

Board Mount (Tjmax = 125 °C)

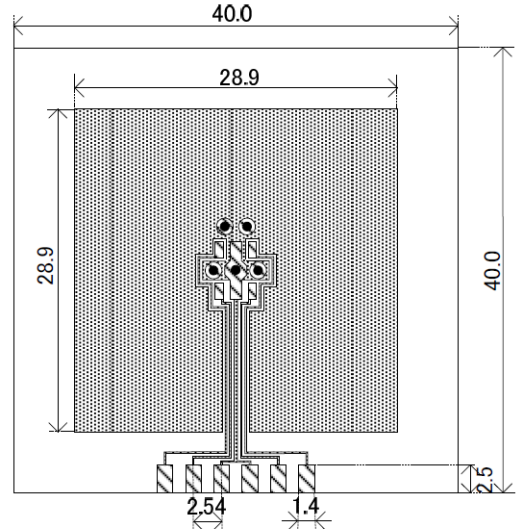

Evaluation Board (Unit: mm)

Ambient Temperature, °C	Power Dissipation Pd, mW	Thermal Resistance, °C/W
25	1000	100.00
85	400	

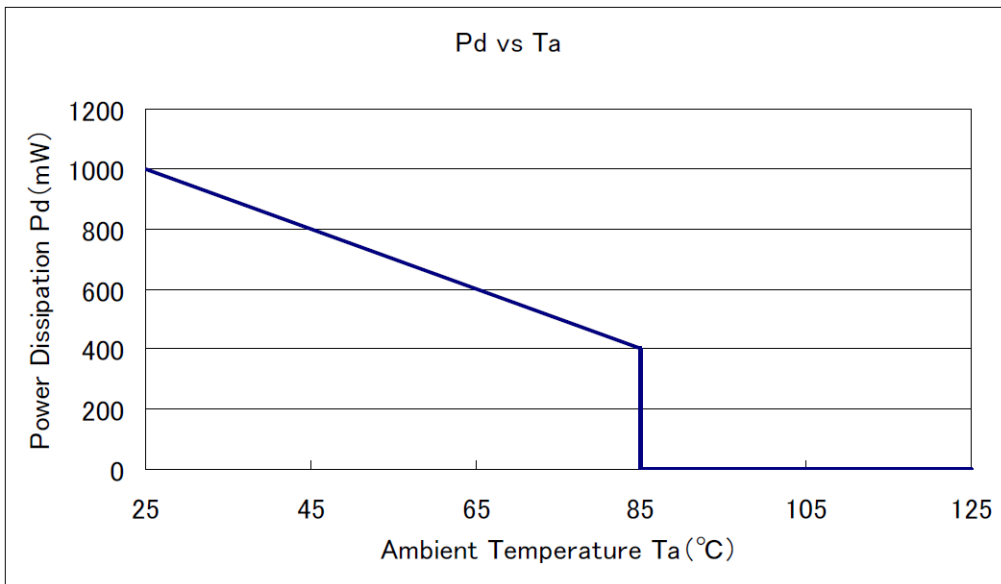

PACKAGE POWER DISSIPATION (CONTINUED)

SOT-89-5 Power Dissipation

The power dissipation varies with the mount board conditions. Please use this data as a reference only.

1. Measurement Conditions:

- Condition: Mount on a board
- Ambient: Natural convection
- Soldering: Lead (Pb) free
- Board: Dimensions 40x40 mm (1600 mm² in one side)
Copper (Cu) traces occupy 50% of the board area on top and bottom layers
Package heat sink tied to the copper traces.
- Material: Glass Epoxy (FR-4)
- Thickness: 1.6 mm
- Through-hole: 5 x 0.8 Diameter

2. Power Dissipation vs. Ambient Temperature

Board Mount (T_{jmax} = 125 °C)

Ambient Temperature, °C	Power Dissipation Pd, mW	Thermal Resistance, °C/W
25	1300	76.92
85	500	

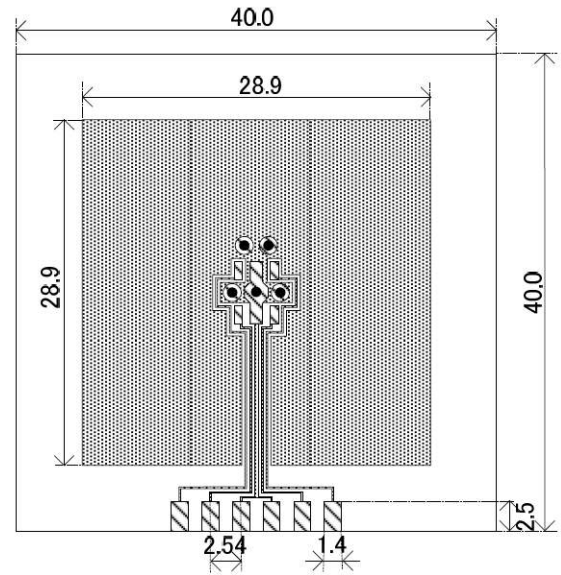

Evaluation Board (Unit: mm)

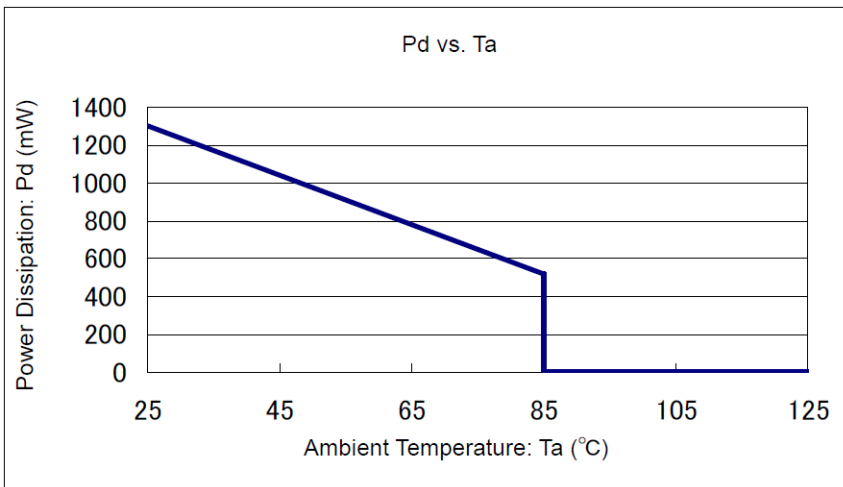

PACKAGE POWER DISSIPATION (CONTINUED)

USP-6C Power Dissipation

The power dissipation varies with the mount board conditions. Please use this data as a reference only.

1. Measurement Conditions:

- Condition: Mount on a board
- Ambient: Natural convection
- Soldering: Lead (Pb) free
- Board: Dimensions 40×40 mm (1600 mm² in one side)
Copper (Cu) traces occupy 50% of the board area on top and bottom layers
Package heat sink teed to copper traces
- Material: Glass Epoxy (FR-4)
- Thickness: 1.6 mm
- Through-hole: 4 x 0.8 Diameter

2. Power Dissipation vs. Ambient Temperature

Board Mount (T_{jmax} = 125 °C)

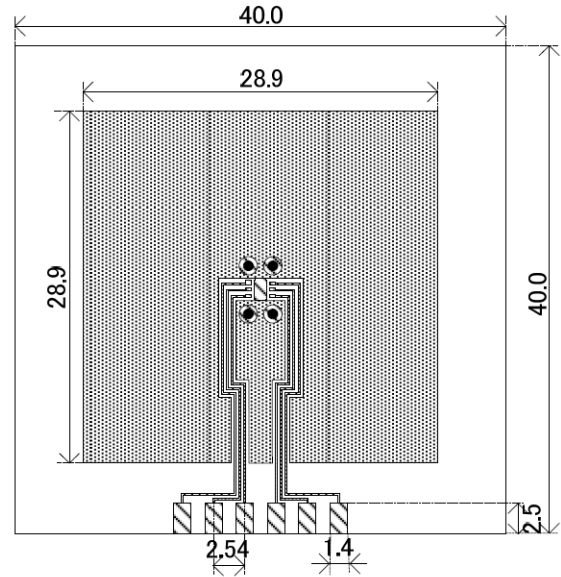

Evaluation Board (Unit: mm)

Ambient Temperature, °C	Power Dissipation Pd, mW	Thermal Resistance, °C/W
25	1000	100.00
85	400	

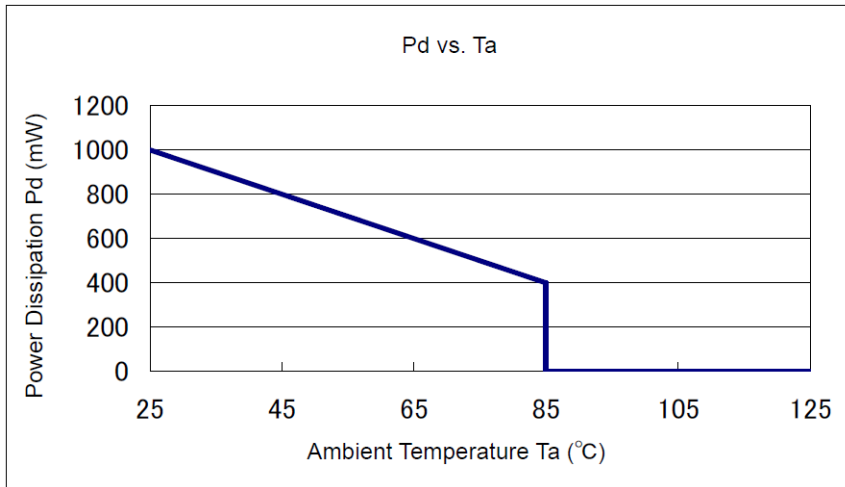

PACKAGE POWER DISSIPATION (CONTINUED)

SOT-223 Power Dissipation

The power dissipation varies with the mount board conditions. Please use this data as a reference only.

1. Measurement Conditions:

- Condition: Mount on a board
- Ambient: Natural convection
- Soldering: Lead (Pb) free
- Board: Dimensions 40x40 mm (1600 mm² in one side)
Copper (Cu) traces occupy 50% of the board area on top and bottom layers
Package heat sink tied to the copper traces.
- Material: Glass Epoxy (FR-4)
- Thickness: 1.6 mm
- Through-hole: 4 x 0.8 Diameter

2. Power Dissipation vs. Ambient Temperature

Board Mount (T_{jmax} = 125 °C)

Ambient Temperature, °C	Power Dissipation Pd, mW	Thermal Resistance, °C/W
25	1500	66.67
85	600	

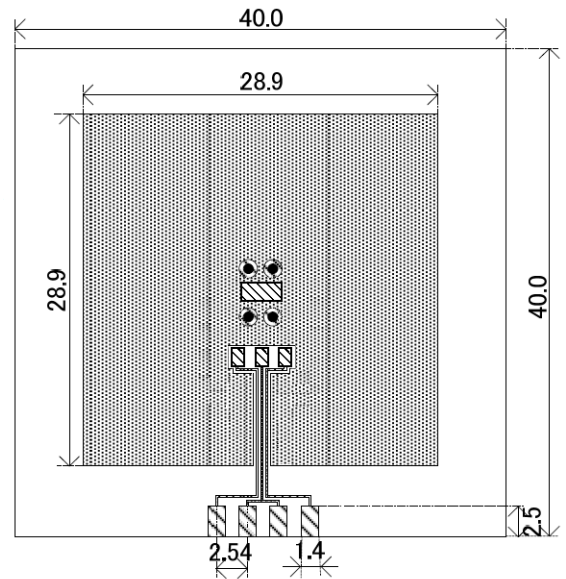

Evaluation Board (Unit: mm)

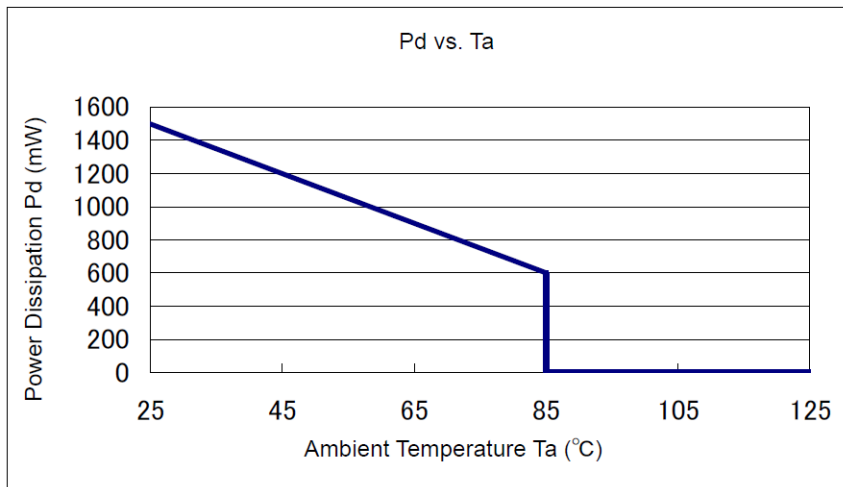

PACKAGE POWER DISSIPATION (CONTINUED)

TO-252 Power Dissipation

The power dissipation varies with the mount board conditions. Please use this data as a reference only.

1. Measurement Conditions:

- Condition: Mount on a board
- Ambient: Natural convection
- Soldering: Lead (Pb) free
- Board: Dimensions 40x40 mm (1600 mm² in one side)
Copper (Cu) traces occupy 50% of the board area on top and bottom layers
Package heat sink tied to the copper traces.
- Material: Glass Epoxy (FR-4)
- Thickness: 1.6 mm
- Through-hole: 4 x 0.8 Diameter

2. Power Dissipation vs. Ambient Temperature

Board Mount (Tjmax = 125 °C)

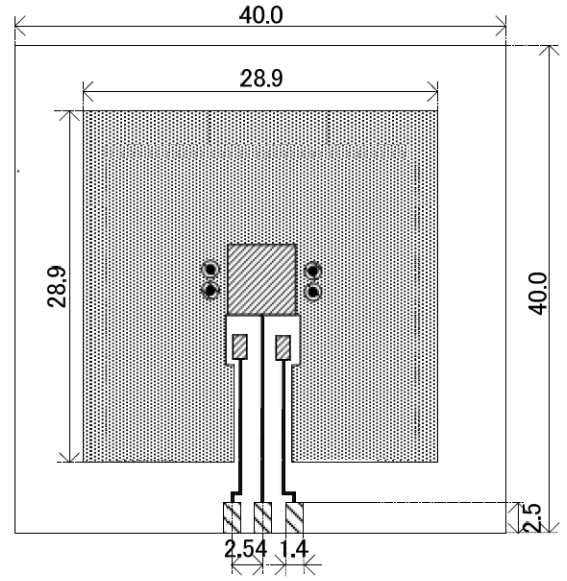

Evaluation Board (Unit: mm)

Ambient Temperature, °C	Power Dissipation Pd, mW	Thermal Resistance, °C/W
25	1800	55.56
85	720	

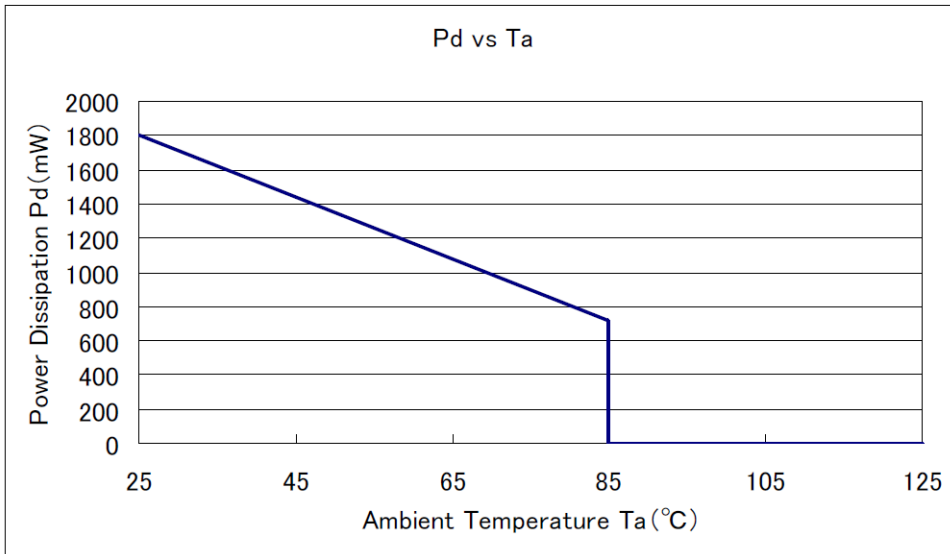

MARKING

SOT-25, SOT-89, SOT89-5, USP-4

SOT-25

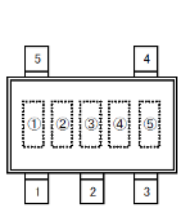

SOT-89-5

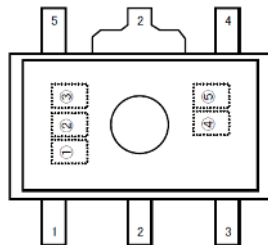

SOT-89

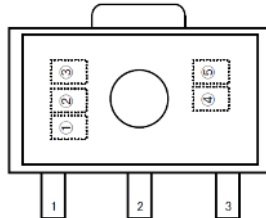

USP-6C

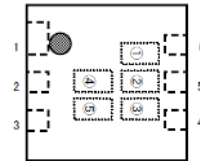

SOT-223

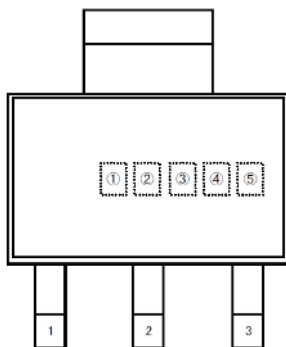

TO-252

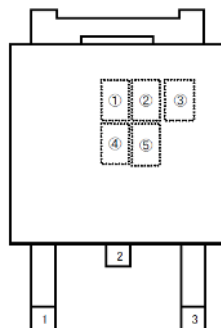

① - represents product series

MARK	PRODUCT SERIES
8	IXD1701xxxxxx

② - represents type of regulator and output voltage range

MARK	TYPE	OUTPUT VOLTAGE, V	PRODUCT SERIES
0	B	1.8 – 3.0	IXD1701Bxxxx
1		3.1 – 6.0	
2		6.1 – 9.0	
3		9.1 - 12.0	
A		12.1 – 15.0	
B	15.1 – 18.0		
4	D	1.8 – 3.0	IXD1701Dxxxx
5		3.1 – 6.0	
6		6.1 – 9.0	
7		9.1 - 12.0	
C		12.1 – 15.0	
D	15.1 – 18.0		

MARKING (CONTINUED)

③ - represents output voltage

MARK	OUTPUT VOLTAGE, V					
0	-	3.1	6.1	9.1	12.1	15.1
1	-	3.2	6.2	9.2	12.2	15.2
2	-	3.3	6.3	9.3	12.3	15.3
3	-	3.4	6.4	9.4	12.4	15.4
4	-	3.5	6.5	9.5	12.5	15.5
5	-	3.6	6.6	9.6	12.6	15.6
6	-	3.7	6.7	9.7	12.7	15.7
7	-	3.8	6.8	9.8	12.8	15.8
8	-	3.9	6.9	9.9	12.9	15.9
9	-	4.0	7.0	10.0	13.0	16.0
A	-	4.1	7.1	10.1	13.1	16.1
B	-	4.2	7.2	10.2	13.2	16.2
C	-	4.3	7.3	10.3	13.3	16.3
D	-	4.4	7.4	10.4	13.4	16.4
E	-	4.5	7.5	10.5	13.5	16.5
F	-	4.6	7.6	10.6	13.6	16.6
H	-	4.7	7.7	10.7	13.7	16.7
K	1.8	4.8	7.8	10.8	13.8	16.8
L	1.9	4.9	7.9	10.9	13.9	16.9
M	2.0	5.0	8.0	11.0	14.0	17.0
N	2.1	5.1	8.1	11.1	14.1	17.1
P	2.2	5.2	8.2	11.2	14.2	17.2
R	2.3	5.3	8.3	11.3	14.3	17.3
S	2.4	5.4	8.4	11.4	14.4	17.4
T	2.5	5.5	8.5	11.5	14.5	17.5
U	2.6	5.6	8.6	11.6	14.6	17.6
V	2.7	5.7	8.7	11.7	14.7	17.7
X	2.8	5.8	8.8	11.8	14.8	17.8
Y	2.9	5.9	8.9	11.9	14.9	17.9
Z	3.0	6.0	9.0	12.0	15.0	18.0

④⑤ - represents production lot number

01~09, 0A~0Z, 11~9Z, A1~A9, AA~AZ, B1~ZZ in order, (G, I, J, O, Q, W excluded)

Customer Support

To share comments, get your technical questions answered, or report issues you may be experiencing with our products, please visit Zilog's Technical Support page at <http://support.zilog.com>. To learn more about this product, find additional documentation, or to discover other facets about Zilog product offerings, please visit the Zilog Knowledge Base at <http://zilog.com/kb> or consider participating in the Zilog Forum at <http://zilog.com/forum>. This publication is subject to replacement by a later edition. To determine whether a later edition exists, please visit the Zilog website at <http://www.zilog.com>.

Warning: DO NOT USE THIS PRODUCT IN LIFE SUPPORT SYSTEMS.

LIFE SUPPORT POLICY ZILOG'S PRODUCTS ARE NOT AUTHORIZED FOR USE AS CRITICAL COMPONENTS IN LIFE SUPPORT DEVICES OR SYSTEMS WITHOUT THE EXPRESS PRIOR WRITTEN APPROVAL OF THE PRESIDENT AND GENERAL COUNSEL OF ZILOG CORPORATION.

As used herein Life support devices or systems are devices which (a) are intended for surgical implant into the body, or (b) support or sustain life and whose failure to perform when properly used in accordance with instructions for use provided in the labeling can be reasonably expected to result in a significant injury to the user. A critical component is any component in a life support device or system whose failure to perform can be reasonably expected to cause the failure of the life support device or system or to affect its safety or effectiveness.

Document Disclaimer ©2015 Zilog, Inc. All rights reserved. Information in this publication concerning the devices, applications, or technology described is intended to suggest possible uses and may be superseded. ZILOG, INC. DOES NOT ASSUME LIABILITY FOR OR PROVIDE A REPRESENTATION OF ACCURACY OF THE INFORMATION, DEVICES, OR TECHNOLOGY DESCRIBED IN THIS DOCUMENT. ZILOG ALSO DOES NOT ASSUME LIABILITY FOR INTELLECTUAL PROPERTY INFRINGEMENT RELATED IN ANY MANNER TO USE OF INFORMATION, DEVICES, OR TECHNOLOGY DESCRIBED HEREIN OR OTHERWISE. The information contained within this document has been verified according to the general principles of electrical and mechanical engineering.