

**Phase-Locked Loop Clock Driver
with 4 Clock Outputs**

Product Features

- High-Performance Phase-Locked-Loop Clock Distribution for Networking
- Registered DIMM Synchronous DRAM modules for server/workstation/PC applications
- Allows Clock Input to have Spread Spectrum modulation for EMI reduction
- Zero Input-to-Output delay
- Low jitter: Cycle-to-Cycle jitter ± 75 ps max.
- On-chip series damping resistor at clock output drivers for low noise and EMI reduction
- Operates at 3.3V V_{CC}
- Wide range of Clock Frequencies 80 to 134 MHz
- Package: Plastic 16-pin QSOP Package (Q)
Plastic 16-pin QSOP Package (QE) Pb-free

Product Description

The PI6C2504A features a low-skew, low-jitter, phase-locked loop (PLL) clock driver, distributing high-frequency clock signals for SDRAM and server applications. By connecting the feedback FB_OUT output to the feedback FB_IN input, the propagation delay from the CLK_IN input to any clock output will be nearly zero.

Logic Block Diagram

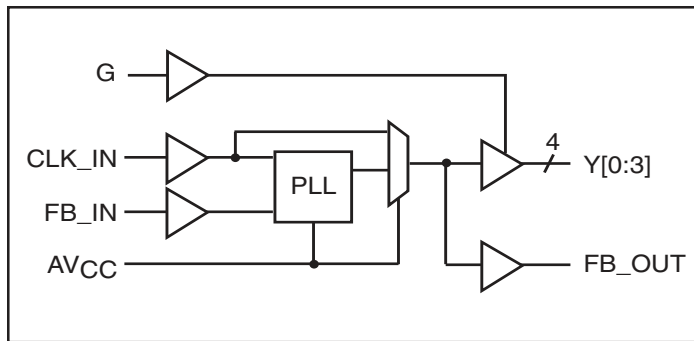

Functional Table

Inputs	Outputs	
G	Y[0:3]	FB_OUT
L	L	CLK_IN
H	CLK_IN	CLK_IN

Product Pin Configuration

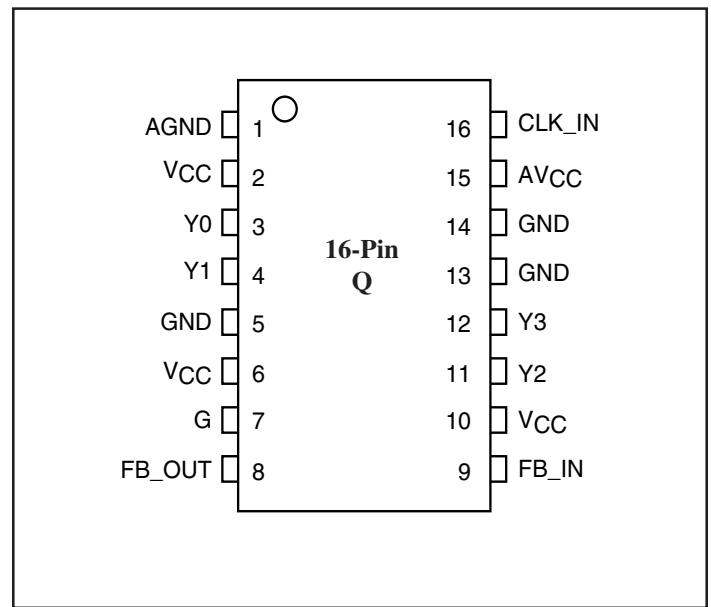

Pin Functions

Pin Name	Pin No.	Type	Description
CLK_IN	16	I	Reference Clock input. CLK_IN allows spread spectrum clock input.
FB_IN	9	I	Feedback input. FB_IN provides the feedback signal to the internal PLL.
G	7	I	Output bank enable. When G is LOW, outputs Y[0:3] are disabled to a logic low state.
FB_OUT	8	O	Feedback output. FB_OUT is dedicated for external feedback. FB_OUT has an embedded series-damping resistor of the same value as the clock outputs Yx.
Y[0:3]	3,4,11,12	O	Clock outputs. These outputs provide low-skew copies of CLK_IN Each output has an embedded series-damping resistor.
AV _{CC}	15	Power	Analog power supply. For test purposes, AV _{CC} can be also used to bypass the PLL. When AV _{CC} is strapped to ground, PLL is bypassed and CLK_IN is buffered directly to the device outputs.
AGND	1	Ground	Analog ground. AGND provides the ground reference for the analog circuitry.
V _{CC}	2, 6, 10	Power	Power supply.
GND	5, 13, 14	Ground	Ground

DC Specifications⁽¹⁾ (Absolute maximum ratings over operating free-air temperature range)

Symbol	Parameter	Min.	Max.	Units
V _I	Input voltage range	-0.5	V _{CC} +0.5	V
V _O	Output voltage range			
V _{I,DC}	DC input voltage		3.8	
I _{O,DC}	DC output current		100	mA
Power	Maximum power dissipation at T _A = 55°C in still air		1.0	W
T _{STG}	Storage temperature	-65	150	°C

Note:

1. Stress beyond those listed under “absolute maximum ratings” may cause permanent damage to the device.

Parameter	Test Conditions	V _{CC}	Min.	Typ.	Max.	Units
I _{CC}	V _I = V _{CC} or GND; I _O = 0 ⁽²⁾ Standby Current	3.6V			10	μA
C _I	V _I = V _{CC} or GND	3.3V		4		pF
C _O	V _O = V _{CC} or GND			6		

Note:

2. Continuous Output Current

Recommended Operating Conditions

Symbol	Parameter	Min.	Max.	Units
V _{CC}	Supply voltage	3.0	3.6	V
V _{IH}	High level input voltage	2.0		
V _{IL}	Low level input voltage		0.8	
V _I	Input voltage	0	V _{CC}	
T _A	Operating free-air temperature	0	70	°C

Electrical Characteristics (Over Recommended Operating Free-Air Temperature Range)

Pull Up/Down Currents of PI6C2504A, $V_{CC} = 3.0V$

Symbol	Parameter	Condition	Min.	Max.	Units
I _{OH}	Pull-up current	V _{out} = 2.4V		-13.6	mA
	Pull-up current	V _{out} = 2.0V		-22	
I _{OL}	Pull-down current	V _{out} = 0.8V	19		
	Pull-down current	V _{out} = 0.55V	13		

AC Specifications

(Timing requirements over recommended ranges of supply voltage and operating free-air temperature)

Symbol	Parameter	Min.	Max.	Units
F _{CLK}	Clock frequency PI6C2504A	80	134	MHz
D _{CYI}	Input clock duty cycle	40	60	%
	Stabilization Time after power up		1	ms

Switching Characteristics⁽³⁾

(Over recommended ranges of supply voltage and operating free-air temperature, CL = 30pF)

Parameter	From (Input)	To (Output)	V _{CC} = 3.3V ±0.3V, 0-70°C			Units
			Min.	Typ.	Max.	
t _{phase error without jitter}	CLK_IN↑ at 100 & 66 MHz	FB_IN↑	-150		+150	ps
Jitter, cycle-to-cycle	At 100 & 66 MHz	CLK_OUT	-75		+75	
Duty cycle			45		55	%
t _r , rise-time, 0.4V to 2.0V					1.0	ns
t _f , fall-time, 2.0V to 0.4V					1.1	

Note:

3. These switching parameters are guaranteed by design.

Package Mechanical Information: 16-pin QSOP Package (Q).

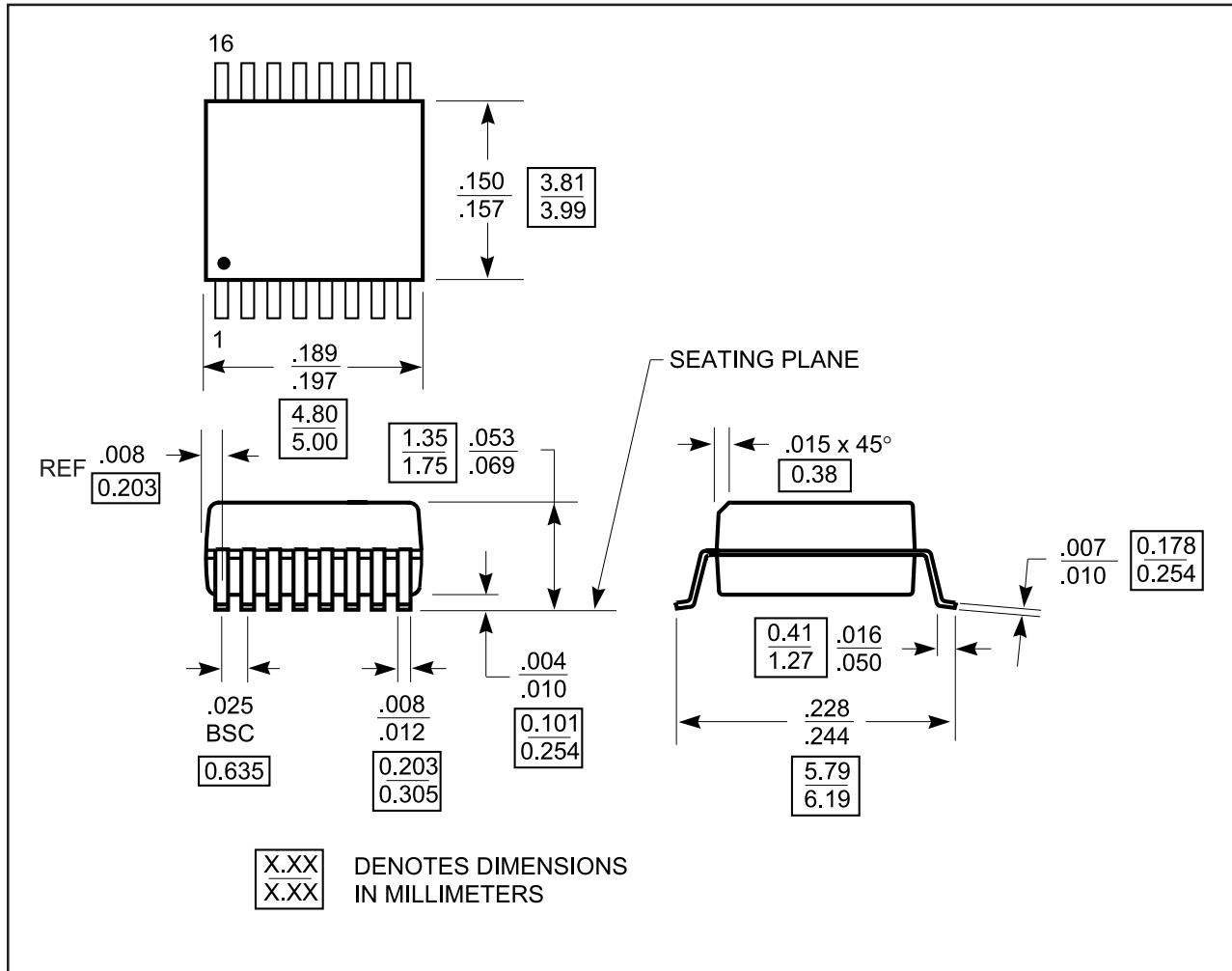

Ordering Information

Ordering Code	Package Name	Package Type	Operating Range
PI6C2504AQ	Q	16-pin QSOP	Commercial
PI6C2504AQE	QE	16-pin QSOP	Commercial