

DESCRIPTION

The MP2496 integrates a monolithic, step-down, switch-mode converter with a single USB current-limit switch and charging port identification circuits. The MP2496 achieves 2.5A of continuous output current with excellent load and line regulation over a wide input supply range.

The output of the USB switch is current-limited. The MP2496 provides a USB dedicated charging port (DCP), which supports battery charging specification 1.2 (BC1.2), divider mode, and 1.2V/1.2V mode, eliminating the need for outside user interaction.

The output voltage has programmable line drop compensation.

Full protection features include hiccup current limiting, output over-voltage protection (OVP), and thermal shutdown.

The MP2496 requires a minimal number of readily available, standard, external components and is available in a QFN-26 (4mmx4mm) package.

FEATURES

- Wide 7V to 36V Operating Input Voltage Range
- Fixed 5V Output Voltage with Line Drop Compensation
- Accurate USB Output Current Limit
- 40mΩ/32mΩ Low- $R_{DS(ON)}$ Internal Buck Power MOSFETs
- 24mΩ Low- $R_{DS(ON)}$ Internal USB Power MOSFET
- 350kHz / 250kHz / 150kHz Frequency Selectable
- Programmable Line Drop Compensation
- Output Over-Voltage Protection (OVP)
- Hiccup Current Limit
- Supports DCP Scheme for BC1.2, Divider Mode, and 1.2V/1.2V Mode
- ±8kV HBM ESD Rating for USB, DP, and DM
- Available in a QFN-26 (4mmx4mm) Package

APPLICATIONS

- USB Dedicated Charging Port (DCP)
- Automotive Cigarette Lighter Adapters
- Power Supply for Linear Chargers

All MPS parts are lead-free, halogen-free, and adhere to the RoHS directive. For MPS green status, please visit the MPS website under Quality Assurance. "MPS" and "The Future of Analog IC Technology" are registered trademarks of Monolithic Power Systems, Inc.

TYPICAL APPLICATION

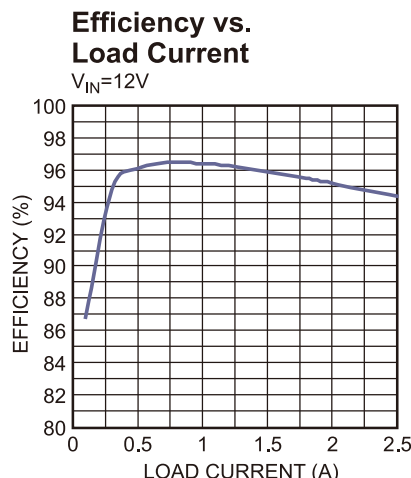
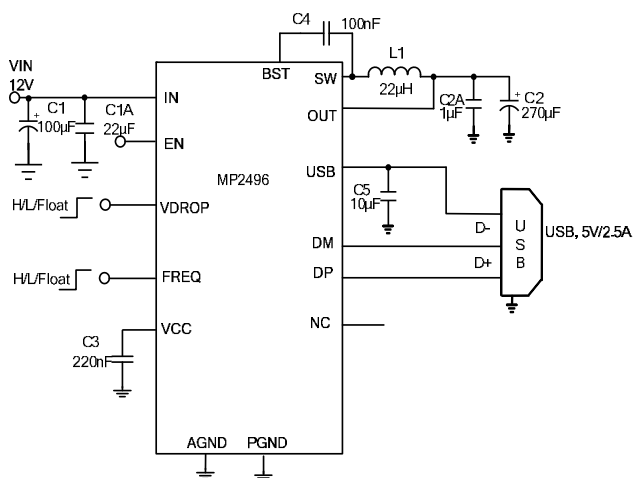

ORDERING INFORMATION

Part Number*	Package	Top Marking
MP2496GR	QFN-26 (4mmx4mm)	See Below

* For Tape & Reel, add suffix -Z (e.g.: MP2496GR-Z).

TOP MARKING

MPSYWW

MP2496

LLLLLL

MPS: MPS prefix
 Y: Year code
 WW: Week code
 MP2496: Product code
 LLLLLL: Lot number

PACKAGE REFERENCE

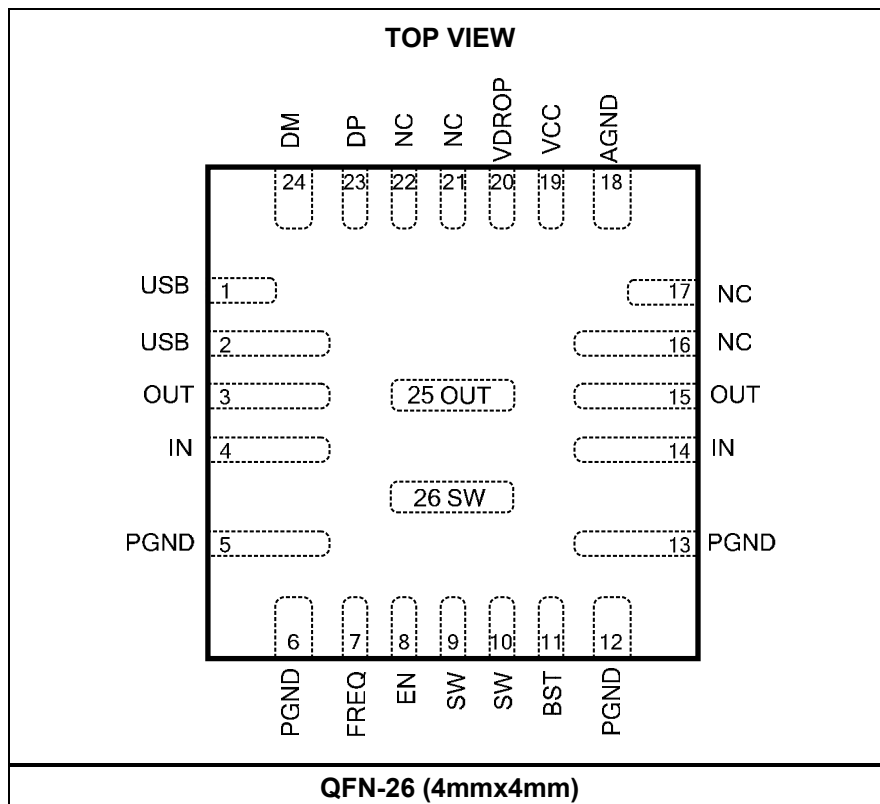

ABSOLUTE MAXIMUM RATINGS ⁽¹⁾

Supply voltage (V_{IN})	40V
V_{SW}	-0.3V (-5V for <10ns) to $V_{IN} + 0.3V$ (43V for <10ns)
V_{BST}	$V_{SW} + 6.5V$
V_{EN}	-0.3V to 10V ⁽²⁾
All other pins	-0.3V to +6.5V
Continuous power dissipation ($T_A = +25^\circ C$) ⁽³⁾	
QFN-26 (4mmx4mm)	2.8W
Junction temperature	150°C
Lead temperature	260°C
Storage temperature	-65°C to +150°C

Recommended Operating Conditions ⁽⁴⁾

Operation input voltage range	7V to 36V
Output current	2.5A for USB
Operating junction temp. (T_J) ..	-40°C to +125°C

Thermal Resistance ⁽⁵⁾	θ_{JA}	θ_{JC}	
QFN-26 (4mmx4mm)	44	9	°C/W

NOTES:

- 1) Exceeding these ratings may damage the device.
- 2) For details on EN's ABS max rating, please refer to the Enable Control section on page 11.
- 3) The maximum allowable power dissipation is a function of the maximum junction temperature T_J (MAX), the junction-to-ambient thermal resistance θ_{JA} , and the ambient temperature T_A . The maximum allowable continuous power dissipation at any ambient temperature is calculated by P_D (MAX) = $(T_J$ (MAX) - T_A) / θ_{JA} . Exceeding the maximum allowable power dissipation produces an excessive die temperature, causing the regulator to go into thermal shutdown. Internal thermal shutdown circuitry protects the device from permanent damage.
- 4) The device is not guaranteed to function outside of its operating conditions.
- 5) Measured on JESD51-7, 4-layer PCB.

ELECTRICAL CHARACTERISTICS

$V_{IN} = 12V$, $V_{EN} = 5V$, $T_J = -40^{\circ}C$ to $+125^{\circ}C$ ⁽⁶⁾. Typical value is tested at $T_J = +25^{\circ}C$, unless otherwise noted.

Parameter	Symbol	Condition	Min	Typ	Max	Units
Supply current (shutdown)	I_{IN}	$V_{EN} = 0V, T_J = +25^{\circ}C$			1	μA
		$V_{EN} = 0V, T_J = -40^{\circ}C$ to $+125^{\circ}C$			5	
Supply current (quiescent)	I_{Q_OL}	No switching		1.6	2.5	mA
EN rising threshold	V_{EN_Rising}		1.33	1.43	1.52	V
EN hysteresis	$V_{EN_Falling}$		110	140	170	mV
EN input current	I_{EN}	$V_{EN} = 2V, T_J = +25^{\circ}C$	1.1	1.8	2.5	μA
		$V_{EN} = 2V, T_J = -40^{\circ}C$ to $+125^{\circ}C$	0.8	1.8	3	
		$V_{EN} = 0V$		0		
Thermal shutdown ⁽⁷⁾	T_{STD}			165		$^{\circ}C$
Thermal hysteresis ⁽⁷⁾	T_{STD_HYS}			20		$^{\circ}C$
VCC regulator	V_{CC}		4.75	5.1	5.45	V
VCC load regulation	V_{CC_LOG}	$I_{CC} = 5mA$		1	2	%
Step-Down Converter						
V_{IN} under-voltage lockout threshold rising	V_{IN_UVLO}	$T_J = +25^{\circ}C$	5.2	5.7	6.2	V
V_{IN} under-voltage lockout threshold hysteresis	V_{UVLO_HYS}			1		V
HS switch on resistance	R_{DSON_HS}			40		m Ω
LS switch on resistance	R_{DSON_LS}			32		m Ω
Output voltage	V_{OUT}	$7V < V_{IN} < 36V$, no load, $T_J = +25^{\circ}C$	5	5.05	5.1	V
		$7V < V_{IN} < 36V$, no load, $T_J = -40^{\circ}C$ to $+125^{\circ}C$	4.95	5.05	5.15	
Output over-voltage protection (OVP)	V_{OVP_R}		5.65	6	6.4	V
OVP recovery	V_{OVP_F}	$T_J = -40^{\circ}C$ to $+125^{\circ}C$	5.4	5.75	6.1	V
Switch leakage	SW_{LKG}	$V_{EN} = 0V, V_{SW} = 36V$ or $0V, T_J = +25^{\circ}C$			1	μA
		$V_{EN} = 0V, V_{SW} = 36V$ or $0V, T_J = -40^{\circ}C$ to $+125^{\circ}C$			5	
Current limit ⁽⁷⁾	I_{LIMIT}	Over 0 - 90% duty cycle	4			A
Oscillator frequency	f_{SW1}	FREQ = high, $T_J = +25^{\circ}C$	310	350	410	kHz
		FREQ = high, $T_J = -40^{\circ}C$ to $+125^{\circ}C$	300	350	420	
	f_{SW2}	FREQ = low, $T_J = +25^{\circ}C$	220	250	300	
		FREQ = low, $T_J = -40^{\circ}C$ to $+125^{\circ}C$	190	250	330	
	f_{SW3}	FREQ = float, $T_J = +25^{\circ}C$	125	150	180	
		FREQ = float, $T_J = -40^{\circ}C$ to $+125^{\circ}C$	110	150	185	
Maximum duty cycle	D_{MAX}	FREQ = 350kHz	84	88		%
Minimum on time ⁽⁷⁾	T_{ON_MIN}	$T_J = +25^{\circ}C$		130		ns
Soft-start time	t_{SS}	Output from 10% to 90%, $T_J = +25^{\circ}C$	1	1.65	2.3	ms
		Output from 10% to 90%, $T_J = -40^{\circ}C$ to $+125^{\circ}C$	0.9	1.65	2.4	

ELECTRICAL CHARACTERISTICS (continued)
 $V_{IN} = 12V$, $V_{EN} = 5V$, $T_J = -40^{\circ}C$ to $+125^{\circ}C$ ⁽⁶⁾. Typical value is tested at $T_J = +25^{\circ}C$, unless otherwise noted.

Parameter	Symbol	Condition	Min	Typ	Max	Units
USB Switch						
Under-voltage lockout threshold rising	V_{USB_UVR}	$T_J = +25^{\circ}C$	3.8	4	4.3	V
		$T_J = -40^{\circ}C$ to $+125^{\circ}C$	3.75	4	4.33	
Under-voltage lockout threshold hysteresis	V_{USB_UVHYS}		220	270	320	mV
Switch-on resistance	R_{DSON_SW}			24		m Ω
Current limit	I_{Limit}	$T_J = +25^{\circ}C$	2.6	2.75	2.9	A
Line drop compensation	V_{DROP_COM1}	Max load 2.4A, $V_{DROP} = \text{float}$, $T_J = +25^{\circ}C$	300	400	500	mV
	V_{DROP_COM2}	Max load 2.4A, $V_{DROP} = \text{high}$		280		mV
	V_{DROP_COM3}	Max load 2.4A, $V_{DROP} = \text{GND}$		130		mV
FREQ, VDROP high level	V_{HIGH}		$V_{CC} - 0.4V$			V
FREQ, VDROP middle level	V_{MIDDLE}			2.5		V
FREQ, VDROP low level	V_{LOW}				0.4	V
V_{BUS} soft-start time	T_{SS}	$V_{OUT} = 5V$, from 10% to 90%, $T_J = +25^{\circ}C$	1	1.6	2.2	ms
		$V_{OUT} = 5V$, from 10% to 90%, $T_J = -40^{\circ}C$ to $+125^{\circ}C$	0.9	1.6	2.4	
Discharge resistance	R_{DCHG}	$T_J = +25^{\circ}C$		50	70	Ω
		$T_J = -40^{\circ}C$ to $+125^{\circ}C$		50	75	
On time of hiccup mode	T_{HICP_ON1}	$V_{OUT} = 5V$, V_{BUS} connected to GND		3 ⁽⁷⁾		ms
	T_{HICP_ON2}	$V_{OUT} = 5V$, $V_{BUS} > 2V$, OC, $T_J = +25^{\circ}C$	3.5	5	6.5	
			$V_{OUT} = 5V$, $V_{BUS} > 2V$, OC, $T_J = -40^{\circ}C$ to $+125^{\circ}C$	3	5	7
Off time of hiccup mode	T_{HICP_OFF}	$V_{OUT} = 5V$, V_{BUS} connected to GND, $T_J = +25^{\circ}C$	6.5	8.5	10.5	s
		$V_{OUT} = 5V$, V_{BUS} connected to GND, $T_J = -40^{\circ}C$ to $+125^{\circ}C$	6	8.5	11	
BC1.2 DCP Mode						
DP and DM short resistance	R_{DP/DM_Short}	$V_{DP} = 0.8V$, $I_{DM} = 1mA$, $T_J = +25^{\circ}C$		125	155	Ω
		$V_{DP} = 0.8V$, $I_{DM} = 1mA$, $T_J = -40^{\circ}C$ to $+125^{\circ}C$		125	160	
Divider Mode						
DP/DM output voltage	$V_{DP/DM_Divider}$	$V_{OUT} = 5V$, $T_J = +25^{\circ}C$	2.54	2.7	2.82	V
		$V_{OUT} = 5V$, $T_J = -40^{\circ}C$ to $+125^{\circ}C$	2.5	2.7	2.85	
DP/DM output impedance	$R_{DP/DM_Divider}$	$T_J = +25^{\circ}C$	20	22	23	k Ω
		$T_J = -40^{\circ}C$ to $+125^{\circ}C$	18	22	28	

ELECTRICAL CHARACTERISTICS (continued)

$V_{IN} = 12V$, $V_{EN} = 5V$, $T_J = -40^{\circ}C$ to $+125^{\circ}C$ ⁽⁶⁾. Typical value is tested at $T_J = +25^{\circ}C$, unless otherwise noted.

Parameter	Symbol	Condition	Min	Typ	Max	Units
1.2V/1.2V Mode						
DP/DM output voltage	$V_{DP/DM_1.2V}$	$V_{OUT} = 5V$, $T_J = +25^{\circ}C$	1.16	1.25	1.34	V
		$V_{OUT} = 5V$, $T_J = -40^{\circ}C$ to $+125^{\circ}C$	1.15	1.25	1.35	
DP/DM output impedance	$R_{DP/DM_1.2V}$	$T_J = +25^{\circ}C$	60	68	75	k Ω
		$T_J = -40^{\circ}C$ to $+125^{\circ}C$	55	68	88	

NOTES:

6) All min/max parameters are tested at $T_J = 25^{\circ}C$. Limits over temperature are guaranteed by design, characterization, and correlation.

7) Guaranteed by design.

TYPICAL PERFORMANCE CHARACTERISTICS

$V_{IN} = 12V$, $V_{OUT} = 5V$, $L = 22\mu H$, $f_s = 250kHz$, $T_A = 25^\circ C$, unless otherwise noted.

Line Drop Compensation vs. Load Current

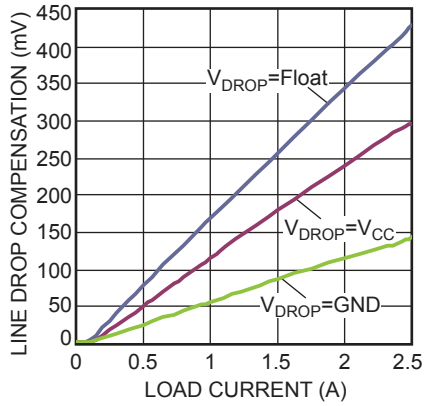

Efficiency vs. Load Current

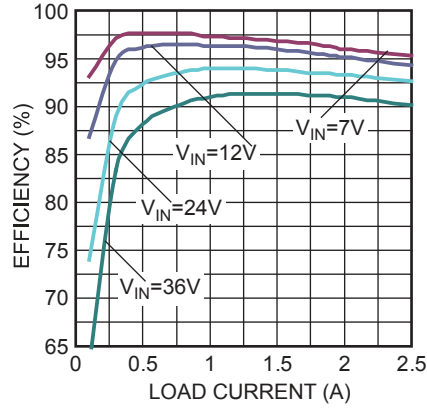

Thermal Test

2 Layer PCB, 4.78cm x 1.38cm
 $T_A=25^\circ C$, No Airflow
 $V_{IN}=12V$, $USB_I_{OUT}=1.1A$

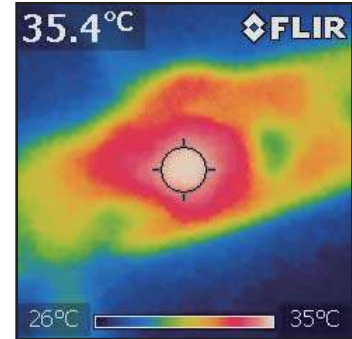

Thermal Test

2 Layer PCB, 4.78cm x 1.38cm
 $T_A=25^\circ C$, No Airflow
 $V_{IN}=12V$, $USB_I_{OUT}=2.5A$

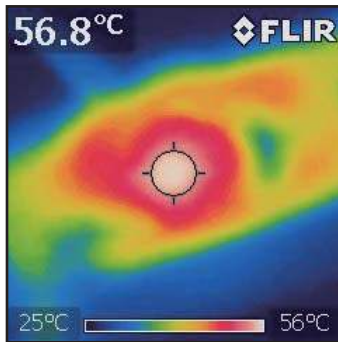

TYPICAL PERFORMANCE CHARACTERISTICS (continued)
 $V_{IN} = 12V$, $V_{OUT} = 5V$, $L = 22\mu H$, $f_s = 250kHz$, $T_A = 25^\circ C$, unless otherwise noted.

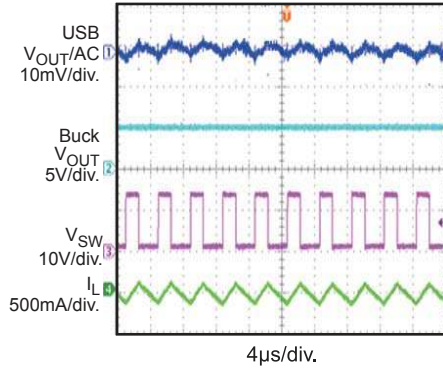
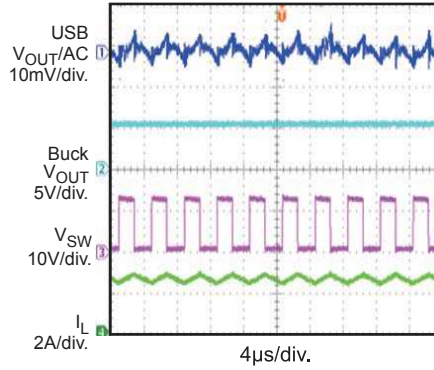
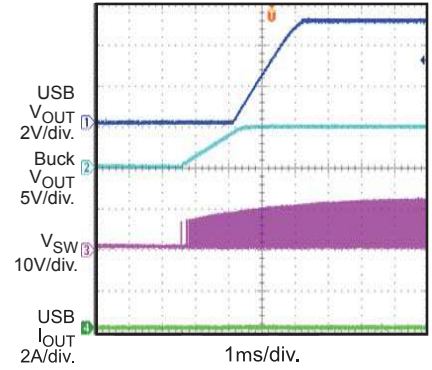
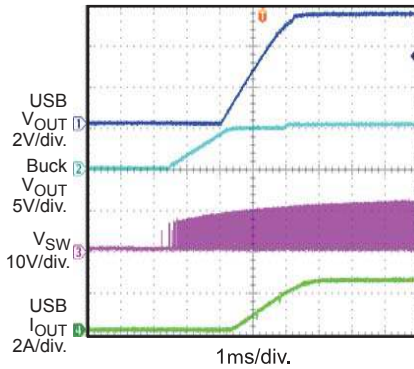
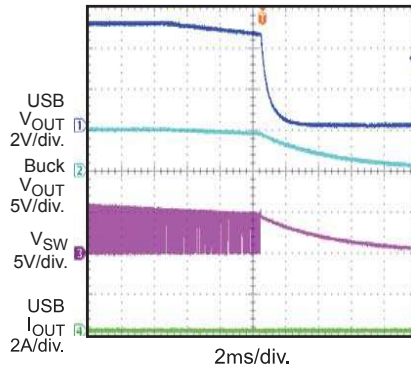
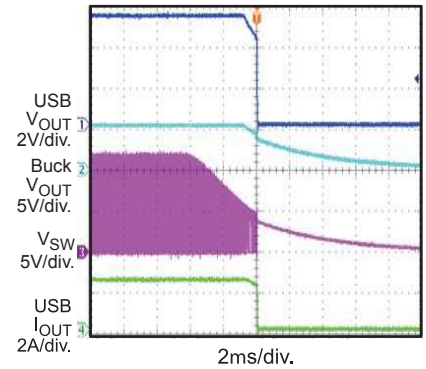
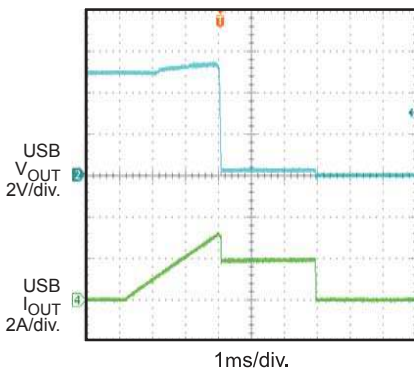
Output Ripple
 $V_{IN} = 12V$, $USB_{I_{OUT}} = 0A$

Output Ripple
 $V_{IN} = 12V$, $USB_{I_{OUT}} = 2.5A$

Power Start-Up
 $V_{IN} = 12V$, $USB_{I_{OUT}} = 0A$

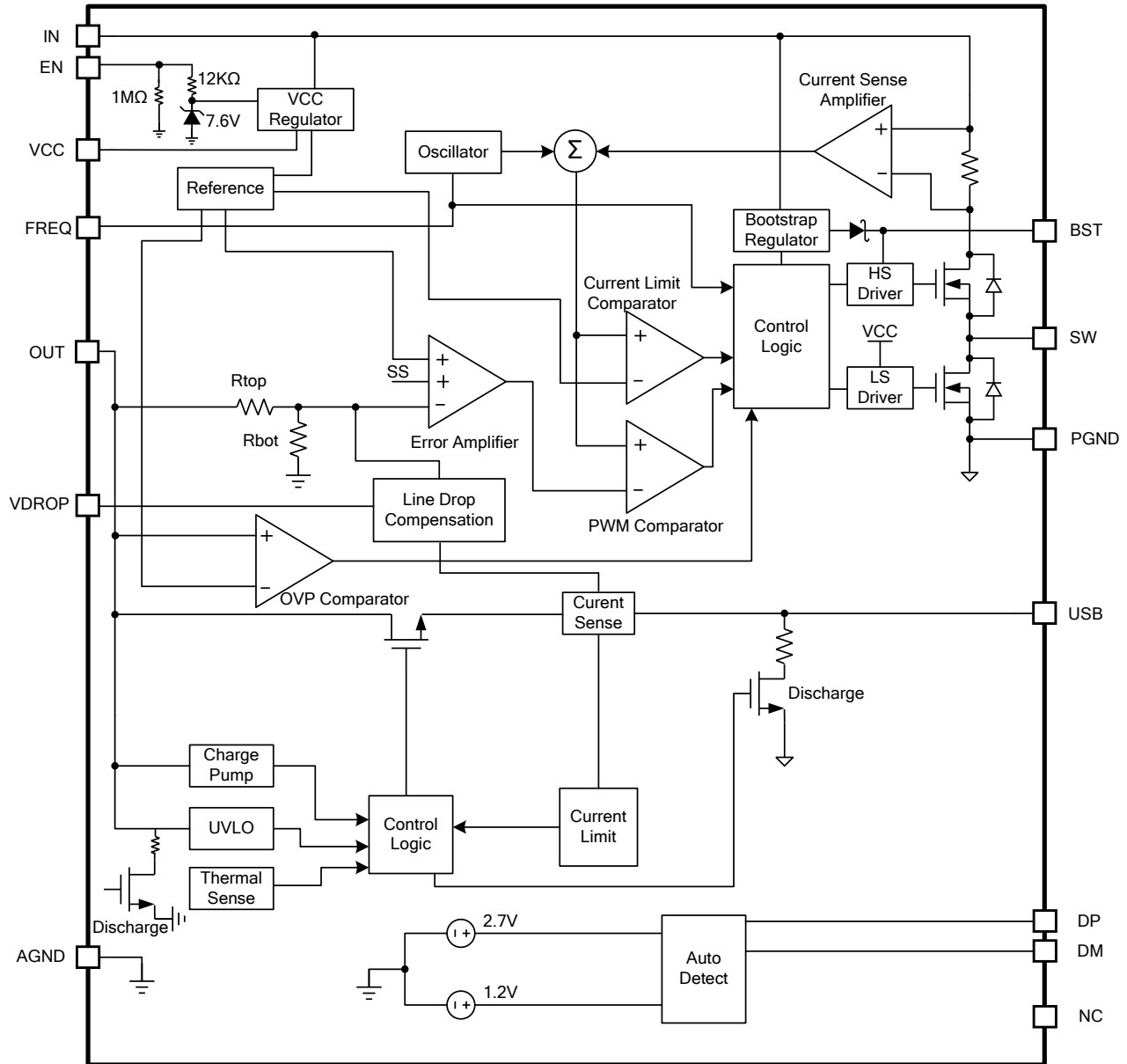
Power Start-Up
 $V_{IN} = 12V$, $USB_{I_{OUT}} = 2.5A$,
CRL Load

Power Shutdown
 $V_{IN} = 12V$, $USB_{I_{OUT}} = 0A$

Power Shutdown
 $V_{IN} = 12V$, $USB_{I_{OUT}} = 2.5A$,
CRL Load

USB Over-Current Protection

PIN FUNCTIONS

QFN-26 Pin #	Name	Description
1, 2	USB	USB output.
3, 15, 25	OUT	Buck output. OUT is the USB's power input. Internal circuits sense the OUT voltage and regulates it at 5V.
4, 14	IN	Supply voltage. IN is the drain of the internal power device and provides power to the entire chip. The MP2496 operates on a 7V to 36V input voltage. A capacitor (C_{IN}) prevents large voltage spikes from appearing at the input. Place C_{IN} as close to the IC as possible.
5, 6, 12, 13	PGND	Power ground. PGND is the reference ground of the regulated output voltage. PGND requires extra care during PCB layout. Connect PGND to GND with copper traces and vias.
7	FREQ	Frequency selection. Floating FREQ sets the frequency at 150kHz. Pulling FREQ to ground sets the frequency at 250kHz. Pulling FREQ high to set the frequency at 350kHz.
8	EN	On/off control input.
9, 10, 26	SW	Switch output. Connect SW using a wide PCB trace.
11	BST	Bootstrap. Connect a 0.1 μ F capacitor between SW and BST to form a floating supply across the high-side switch driver.
16, 17	NC	No connection. NC (pin 16, 17) can be connected to OUT for better thermal dissipation.
18	AGND	Analog ground. Connect AGND to PGND.
19	VCC	Internal 5V LDO regulator output. Decouple VCC with a 0.22 μ F capacitor.
20	VDROP	Line drop compensation selection. Refer to the EC table on page 5 for detailed specifications.
21, 22	NC	No connection. NC (pin 21, 22) must be left floating.
23	DP	D+ data line to the USB connector. DP is the input/output used for handshaking with portable devices.
24	DM	D- data line to the USB connector. DM is the input/output used for handshaking with portable devices.

BLOCK DIAGRAM

Figure 1: Functional Block Diagram

OPERATION

BUCK CONVERTER SECTION

The MP2496 integrates a monolithic, synchronous, rectified, step-down, switch-mode converter with internal power MOSFETs and a USB current-limit switch with charging port auto-detection. The MP2496 offers a very compact solution that achieves 2.5A of continuous output current with excellent load and line regulation over a wide input supply range.

The MP2496 operates in a fixed-frequency, peak-current-mode control to regulate the output voltage. The internal clock initiates the pulse-width modulation (PWM) cycle, which turns on the integrated high-side power MOSFET (HS-FET). The HS-FET remains on until its current reaches the value set by the COMP voltage (V_{COMP}). If the power switch is off, it remains off until the next clock cycle begins. If the duty cycle reaches 88% (350kHz switching frequency) in one PWM period, the current in the power MOSFET will not reach the COMPT-set current value, and the power MOSFET turns off.

Error Amplifier (EA)

The error amplifier (EA) compares the internal feedback voltage (V_{FB}) against the internal 1V reference (REF) and outputs a V_{COMP} value. This V_{COMP} controls the power MOSFET current. The optimized internal compensation network minimizes the external component count and simplifies the control loop design.

VCC Regulator

The 5V internal regulator powers most of the internal circuitries. This regulator takes V_{IN} and operates in the full V_{IN} range. When V_{IN} is greater than 5.0V, the output of the regulator is in full regulation. If V_{IN} is lower than 5.0V, the output voltage decreases with V_{IN} . VCC requires an external 0.22 μ F ceramic capacitor for decoupling.

Enable Control (EN)

The MP2496 has an enable control pin (EN). Pulling EN high enables the IC. Pulling EN low disables the IC. Connect EN to V_{IN} through a resistor for automatic start-up. An internal 1M Ω resistor from EN to GND allows EN to be

floated to shut down the IC. EN is clamped internally using a 7.6V series Zener diode (see Figure 2). Connect EN through a pull-up resistor to the voltage on V_{IN} . This requires limiting the amplitude of the voltage source below 10V and the EN input current less than 230 μ A to prevent damage to the Zener diode.

For example, if connecting 36V to V_{IN} , then $R_{PULLUP} \geq (36V - 10V) / 230\mu A = 113k\Omega$.

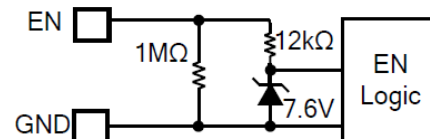

Figure 2: Zener Diode between EN and GND

Under-Voltage Lockout (UVLO)

Under-voltage lockout (UVLO) protects the chip from operating at an insufficient supply voltage. The UVLO comparator monitors the input voltage. The UVLO rising threshold is 5.7V, and its falling threshold is 4.7V.

Internal Soft Start (SS)

Soft start (SS) prevents the converter output voltage from overshooting during start-up. When the chip starts up, the internal circuitry generates a SS voltage that ramps up from 0V to 5V. When SS is lower than REF, the error amplifier uses SS as the reference. When SS is higher than REF, the error amplifier uses REF as the reference. The SS time is set to 1.65ms internally.

If the output of the MP2496 is pre-biased to a certain voltage during start-up, the IC disables the switching of both the high-side and low-side switches until the voltage on the internal SS capacitor exceeds the internal feedback voltage.

Buck Over-Current Protection (OCP)

The MP2496 implements a cycle-by-cycle, over-current limit when the inductor peak current exceeds the current-limit threshold and V_{FB} drops below the under-voltage (UV) threshold (typically 70% below the reference). Once UV is triggered, the MP2496 enters hiccup mode to restart the part periodically. This protection mode is especially useful when the output is dead-short-circuited to ground. The average short-circuit current is reduced greatly, alleviating thermal issues and protecting the

regulator. The MP2496 exits hiccup mode once the over-current condition is removed.

Buck Output Over-Voltage Protection (OVP)

The MP2496 has an output over-voltage protection (OVP). If the output rises higher than 6V, the high-side switch stops switching, and the low-side switch turns on to discharge the output voltage until the output decreases to 5.75V. The chip then resumes normal operation. If the output over-voltage cannot be discharged to 5.75V, the low-side switch turns off after the inductor current reaches a negative current limit. The low-side switch remains off until the next clock cycle begins.

Floating Driver and Bootstrap Charging

An external bootstrap capacitor powers the floating power MOSFET driver. This floating driver has its own UVLO protection. The UVLO's rising threshold is 2.2V with a hysteresis of 150mV. The bootstrap capacitor voltage is regulated internally by V_{IN} through D1, M1, C4, L1, and C2 (see Figure 3). If $V_{BST} - V_{SW}$ exceeds 5V, U1 regulates M1 to maintain a 5V BST voltage across C4.

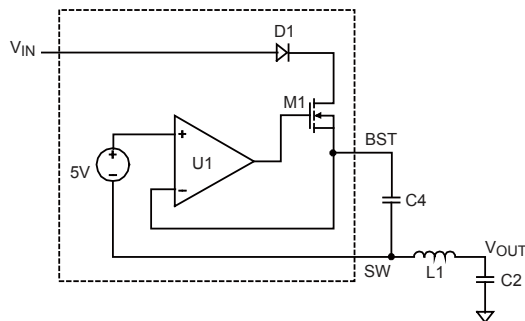

Figure 3: Internal Bootstrap Charging Circuit

Start-Up and Shutdown

If both V_{IN} and EN exceed their respective thresholds, the chip is enabled. The reference block starts first, generating a stable reference voltage and current, and then the internal regulator is enabled. The regulator provides a stable supply for the remaining circuitries.

Three events can shut down the chip: EN low, V_{IN} low, and thermal shutdown. During shutdown, the signaling path is blocked to avoid any fault triggering, and V_{COMP} and the internal supply rail are pulled down. The floating driver is not subject to this shutdown command.

Buck Output Discharge

The buck portion of the device involves a discharge function that provides a resistive discharge path for the external output capacitor. The function is active when the part is disabled (input voltage is under UVLO, EN off) and is done in a very limited amount of time. After VCC is discharged below 1V, the buck output discharge resistor disconnects.

USB CURRENT-LIMIT SWITCH SECTION

Current-Limit Switch

The MP2496 has a single-channel, USB, current-limit switch. It provides a built-in, soft-start circuitry that controls the rising slew rate of the output voltage to limit inrush current and voltage surges.

When the load current reaches the current-limit threshold (typically 2.75A), the USB power MOSFET switches to foldback current-limit mode, 70% of the current limit (see Figure 4). If the over-current limit condition lasts longer than 3ms, the chip enters hiccup mode with 3ms of on-time and 8.5s of off-time.

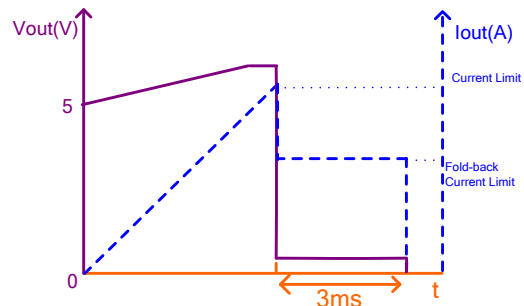

Figure 4: Over-Current Limit

During V_{IN} or EN start-up, ensure that the CC load current does not exceed 70% of the current limit to avoid triggering a foldback current limit and start-up failure.

Output Line Drop Compensation

The MP2496 is capable of compensating for an output voltage drop, such as high impedance caused by a long trace, to maintain a fairly constant 5V load-side voltage.

The MP2496 uses the internal current sense output voltage of the current-limit switch to compensate for the line drop voltage. Since the trace resistance varies for different cables, the MP2496 provides selectable line drop

compensation through VDROP. The line drop compensation amplitude increases linearly as the load current increases and also has an upper limitation.

USB Output Over-Voltage Protection (OVP)

To protect the device at the cable terminal, the USB switch output has a dynamic over-voltage protection threshold. Based on different USB loading currents, the MP2496 adjusts the OVP threshold accordingly.

The intelligent line drop compensation and dynamic OVP control scheme ensure that the voltage at the cable terminal meets the 4.75V - 5.25V specification.

USB Output Discharge

The USB portion involves a discharge function that provides a resistive discharge path for the external output capacitor. The function is active when the part is disabled (input voltage is under UVLO, EN off) and is done in a very limited amount of time.

Auto-Detection

The MP2496 integrates a USB-dedicated charging port auto-detect function. This function recognizes most mainstream portable devices. It supports the following charging schemes:

- USB battery charging specification BC1.2/ Chinese Telecommunications Industry Standard YD/T 1591-2009
- Divider mode
- 1.2V/1.2V mode

The auto-detect function is a state machine that supports all of the DCP charging schemes above.

Thermal Shutdown

Thermal shutdown prevents the chip from operating at exceedingly high temperatures. When the silicon die temperature exceeds 165°C, the entire chip shuts down. When the temperature falls below its lower threshold (typically 145°C), the chip is enabled.

APPLICATION INFORMATION

Selecting the Inductor

For most applications, an inductor with a DC current rating at least 25% higher than the maximum load current is recommended. Select an inductor with a small DC resistance for optimum efficiency. The inductor value for most designs can be estimated with Equation (1):

$$L_1 = \frac{V_{OUT} \times (V_{IN} - V_{OUT})}{V_{IN} \times \Delta I_L \times f_{OSC}} \quad (1)$$

Where ΔI_L is the inductor ripple current.

Set the inductor ripple current to approximately 30% of the maximum load current. The maximum inductor peak current can be calculated with Equation (2):

$$I_{L(MAX)} = I_{LOAD} + \frac{\Delta I_L}{2} \quad (2)$$

A 22 μ H inductance is recommended to improve EMI.

Selecting the Buck Input Capacitor

The input current to the step-down converter is discontinuous and therefore requires a capacitor to supply AC current to the step-down converter while maintaining the DC input voltage. Low ESR capacitors are recommended for the best performance. Ceramic capacitors with X5R or X7R dielectrics are highly recommended because of their low ESR and small temperature coefficients. For CLA applications, a low ESR 100 μ F electrolytic capacitor, two 10 μ F ceramic capacitors, and two 0.1 μ F decoupling ceramic capacitors are recommended for EMI reduction.

Since the input capacitor (C1) absorbs the input switching current, it requires an adequate ripple current rating. The RMS current in the input capacitor can be estimated with Equation (3):

$$I_{C1} = I_{LOAD} \times \sqrt{\frac{V_{OUT}}{V_{IN}} \times \left(1 - \frac{V_{OUT}}{V_{IN}}\right)} \quad (3)$$

The worst-case condition occurs at $V_{IN} = 2V_{OUT}$, shown in Equation (4):

$$I_{C1} = \frac{I_{LOAD}}{2} \quad (4)$$

For simplification, choose an input capacitor with an RMS current rating greater than half of the maximum load current.

The input capacitor can be electrolytic, tantalum, or ceramic. When using electrolytic capacitors, add two high-quality ceramic capacitors as close to the IC's IN pin as possible. The input voltage ripple caused by the capacitance can be estimated with Equation (5):

$$\Delta V_{IN} = \frac{I_{LOAD}}{f_s \times C1} \times \frac{V_{OUT}}{V_{IN}} \times \left(1 - \frac{V_{OUT}}{V_{IN}}\right) \quad (5)$$

Selecting the Buck Output Capacitor

The device requires an output capacitor (C2) to maintain the DC output voltage. Estimate the output voltage ripple with Equation (6):

$$\Delta V_{OUT} = \frac{V_{OUT}}{f_s \times L_1} \times \left(1 - \frac{V_{OUT}}{V_{IN}}\right) \times \left(R_{ESR} + \frac{1}{8 \times f_s \times C2}\right) \quad (6)$$

Where L_1 is the inductor value, and R_{ESR} is the equivalent series resistance (ESR) value of the output capacitor.

For tantalum or electrolytic capacitors, the ESR dominates the impedance at the switching frequency. For simplification, the output ripple can be approximated with Equation (7):

$$\Delta V_{OUT} = \frac{V_{OUT}}{f_s \times L_1} \times \left(1 - \frac{V_{OUT}}{V_{IN}}\right) \times R_{ESR} \quad (7)$$

The characteristics of the output capacitor affect the stability of the regulation system. Low ESR electrolytic capacitors are recommended for low output ripple and good control loop stability. For CLA applications, a 270 μ F polymer/electrolytic capacitor with ~20m Ω ESR and one 1 μ F ceramic capacitor are recommended.

PCB Layout Guidelines ⁽⁸⁾

Efficient PCB layout is critical for stable operation and thermal dissipation. For best results, refer to Figure 5 and follow the guidelines below.

1. Connect the IC's OUT with short, direct, and wide traces.
2. Add vias under the IC.
3. Route the OUT trace on both PCB layers.
4. Use a large copper plane for PGND.
5. Add multiple vias for better thermal dissipation.

6. Connect AGND to PGND.
7. Use a large copper plane for SW and USB.
8. Place the USB output capacitor close to the USB.
9. Place two ceramic input decoupling capacitors as close to IN and PGND as possible to improve EMI performance.
10. Place the VCC decoupling capacitor as close to VCC as possible.

NOTE:

8) The recommended layout is based on the Typical Application Circuit shown in Figure 6.

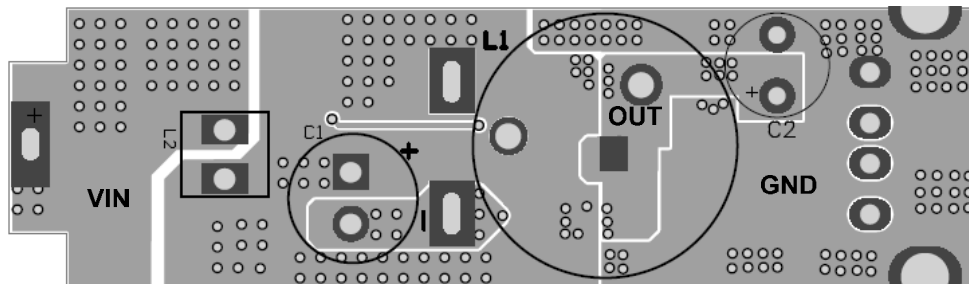
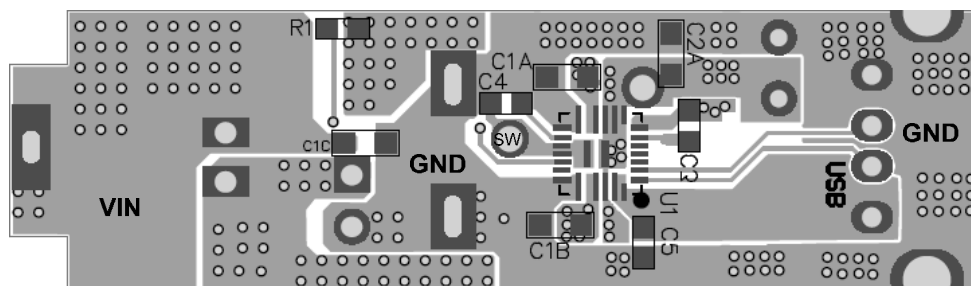
Top Layer

Bottom Layer

(4.78cm x 1.38cm)

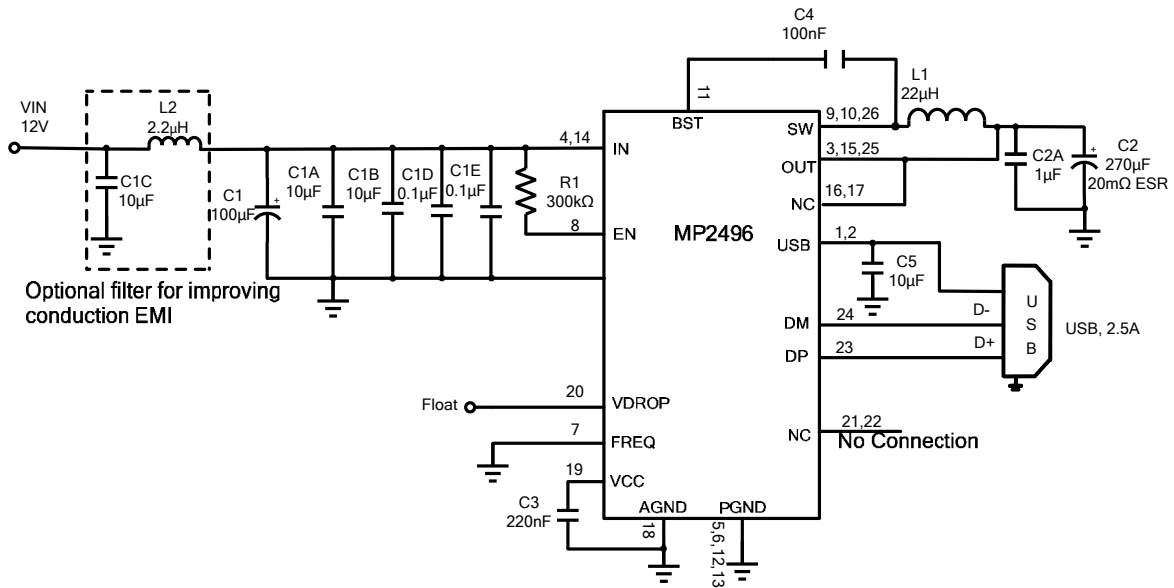
Figure 5: Recommended Layout

TYPICAL APPLICATION CIRCUIT

Figure 6: $V_{IN} = 12V$, USB = 5V/2.5A

PACKAGE INFORMATION

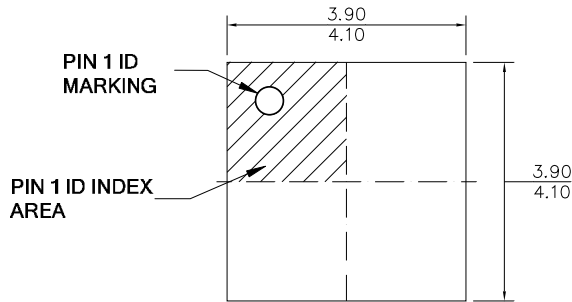
QFN-26 (4mmx4mm)

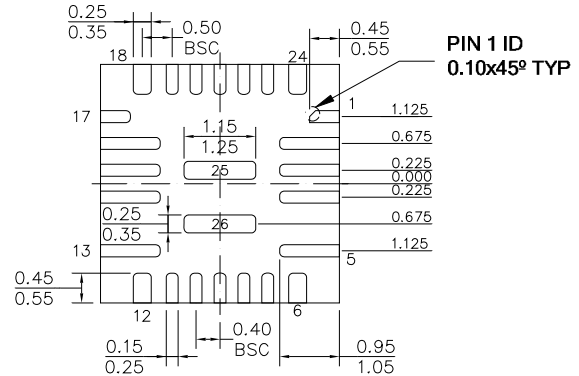

TOP VIEW



BOTTOM VIEW

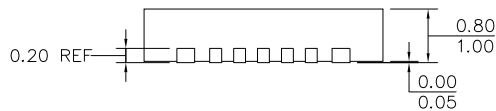

SIDE VIEW

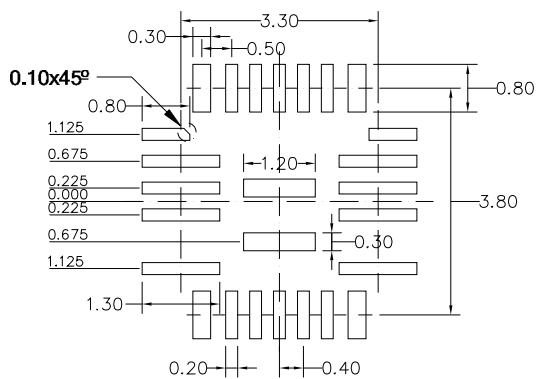

RECOMMENDED LAND PATTERN

NOTE:

- 1) ALL DIMENSIONS ARE IN MILLIMETERS.
- 2) EXPOSED PADDLE SIZE DOES NOT INCLUDE MOLD FLASH.
- 3) LEAD COPLANARITY SHALL BE 0.10 MILLIMETERS MAX.
- 4) JEDEC REFERENCE IS MO-220.
- 5) DRAWING IS NOT TO SCALE.

NOTICE: The information in this document is subject to change without notice. Users should warrant and guarantee that third party Intellectual Property rights are not infringed upon when integrating MPS products into any application. MPS will not assume any legal responsibility for any said applications.