

CBT3257A

Quad 1-of-2 multiplexer/demultiplexer

Rev. 5 — 4 April 2013

Product data sheet

1. General description

The CBT3257A is a quad 1-of-2 high-speed TTL-compatible multiplexer/demultiplexer. The low ON resistance of the switch allows inputs to be connected to outputs without adding propagation delay or generating additional ground bounce noise.

Output enable (\overline{OE}) and select-control (S) inputs select the appropriate nB1 and nB2 outputs for the nA input data.

The CBT3257A is characterized for operation from $-40\text{ }^{\circ}\text{C}$ to $+85\text{ }^{\circ}\text{C}$.

2. Features and benefits

- $5\ \Omega$ switch connection between two ports
- TTL-compatible input levels
- Minimal propagation delay through the switch
- Latch-up protection exceeds 100 mA per JEDEC standard JESD78 class II level A
- ESD protection:
 - ◆ HBM JESD22-A114F exceeds 2000 V
 - ◆ MM JESD22-A115-A exceeds 200 V
 - ◆ CDM JESD22-C101E exceeds 1000 V
- Multiple package options
- Specified from $-40\text{ }^{\circ}\text{C}$ to $+85\text{ }^{\circ}\text{C}$



3. Ordering information

Table 1. Ordering information

| Type number | Temperature range | Package | | |
|-------------|-------------------|-----------------------|--|----------|
| | | Name | Description | Version |
| CBT3257AD | -40 °C to +85 °C | SO16 | plastic small outline package; 16 leads; body width 3.9 mm | SOT109-1 |
| CBT3257ADB | -40 °C to +85 °C | SSOP16 | plastic shrink small outline package; 16 leads; body width 5.3 mm | SOT338-1 |
| CBT3257ADS | -40 °C to +85 °C | SSOP16 ^[1] | plastic shrink small outline package; 16 leads; body width 3.9 mm; lead pitch 0.635 mm | SOT519-1 |
| CBT3257APW | -40 °C to +85 °C | TSSOP16 | plastic thin shrink small outline package; 16 leads; body width 4.4 mm | SOT403-1 |
| CBT3257ABQ | -40 °C to +85 °C | DHVQFN16 | plastic dual in-line compatible thermal enhanced very thin quad flat package; no leads; 16 terminals; body 2.5 × 3.5 × 0.85 mm | SOT763-1 |

[1] Also known as QSOP16.

4. Functional diagram

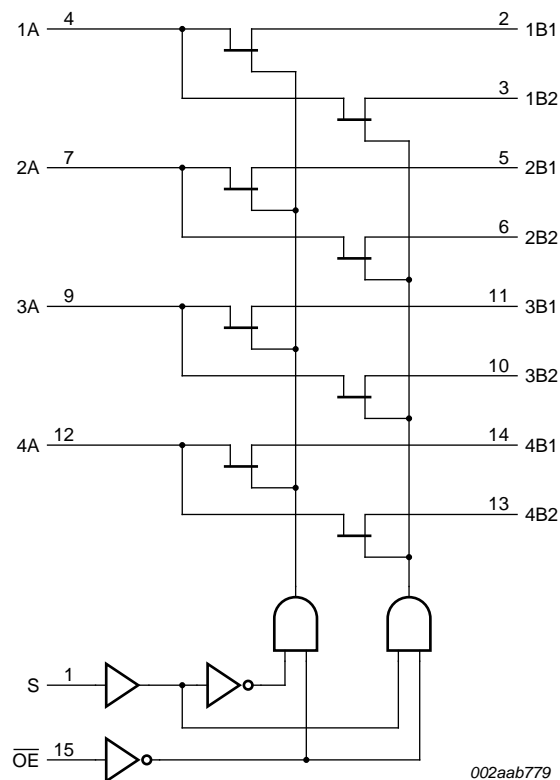
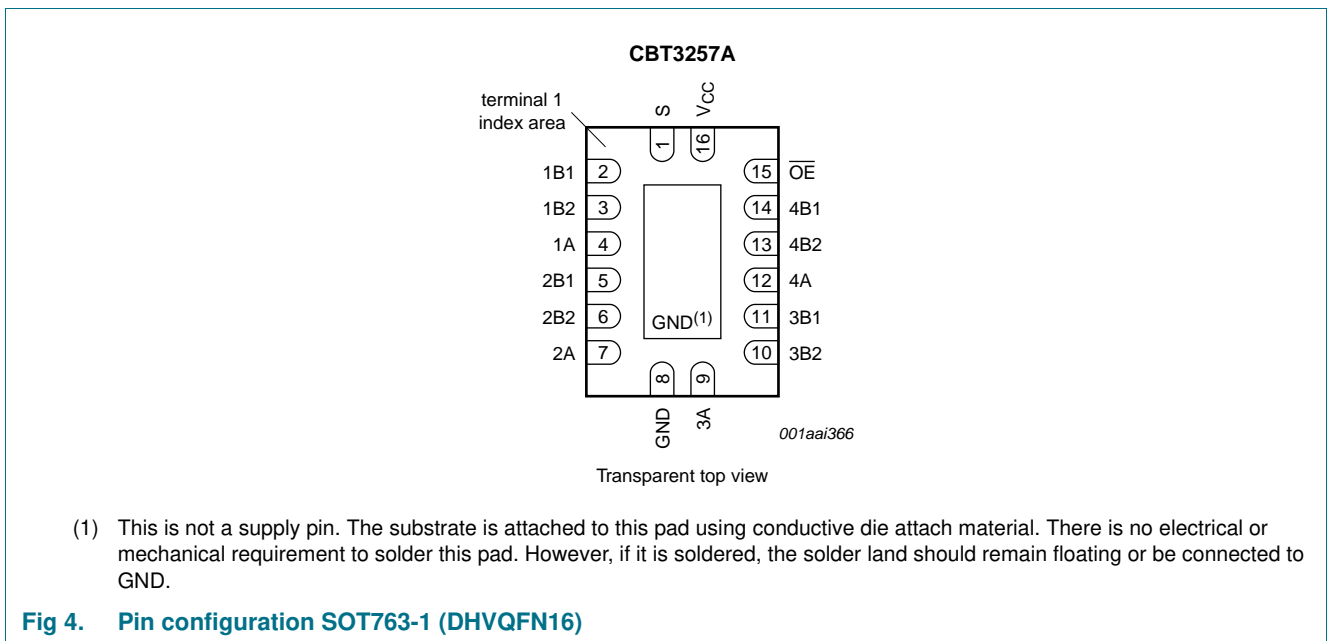
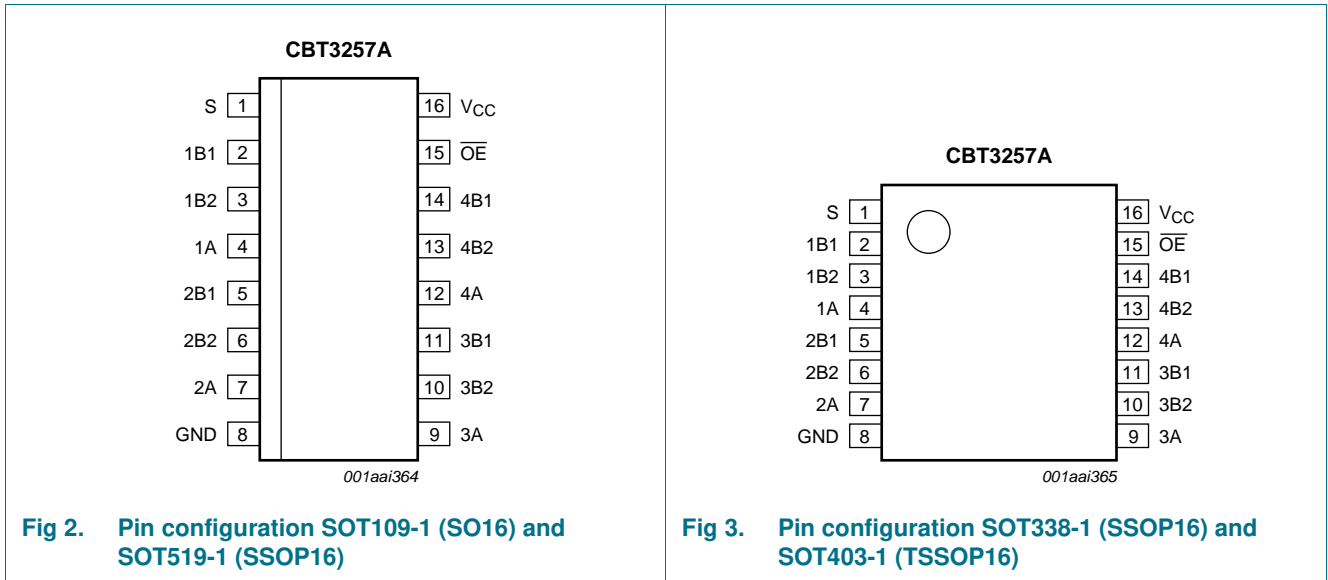

Fig 1. Logic diagram

5. Pinning information

5.1 Pinning



5.2 Pin description

Table 2. Pin description

| Symbol | Pin | Description |
|------------------------|--------------|----------------------------|
| S | 1 | select control input |
| 1B1, 2B1, 3B1, 4B1, | 2, 5, 11, 14 | B1 outputs/inputs |
| 1B2, 2B2, 3B2, 4B2 | 3, 6, 10, 13 | B2 outputs/inputs |
| 1A, 2A, 3A, 4A | 4, 7, 9, 12 | A inputs/outputs |
| GND | 8 | ground (0 V) |
| $\overline{\text{OE}}$ | 15 | output enable (active LOW) |
| V _{CC} | 16 | positive supply voltage |

6. Functional description

Table 3. Function selection

H = HIGH voltage level; L = LOW voltage level; X = Don't care.

| Inputs | | Switch |
|--------|---|------------|
| OE | S | |
| L | L | nA to nB1 |
| L | H | nA to nB2 |
| H | X | switch off |

7. Limiting values

Table 4. Limiting values

In accordance with the Absolute Maximum Rating System (IEC 60134).

| Symbol | Parameter | Conditions | Min | Max | Unit |
|------------------|-------------------------|--|----------|------|------|
| V _{CC} | supply voltage | | -0.5 | +7.0 | V |
| V _I | input voltage | | [1] -0.5 | +7.0 | V |
| I _{SW} | switch current | continuous current through each switch | - | 128 | mA |
| I _{IK} | input clamping current | V _I < 0 V | -50 | - | mA |
| T _{stg} | storage temperature | | -65 | +150 | °C |
| P _{tot} | total power dissipation | T _{amb} = -40 °C to +85 °C | | | |
| | | SO16 package | [2] - | 500 | mW |
| | | SSOP16 package | [3] - | 500 | mW |
| | | TSSOP16 package | [3] - | 500 | mW |
| | | DHVQFN16 package | [4] - | 500 | mW |

[1] The input and output negative voltage ratings may be exceeded if the input and output clamp current ratings are observed.

[2] For SO16 package: P_{tot} derates linearly with 8 mW/K above 70 °C.

[3] For SSOP16 and TSSOP16 package: P_{tot} derates linearly with 5.5 mW/K above 70 °C.

[4] For DHVQFN16 package: P_{tot} derates linearly with 4.5 mW/K above 70 °C.

8. Recommended operating conditions

Table 5. Operating conditions

All unused control inputs of the device must be held at V_{CC} or GND to ensure proper device operation.

| Symbol | Parameter | Conditions | Min | Max | Unit |
|-----------|--------------------------|-----------------------|-----|-----|------|
| V_{CC} | supply voltage | | 4.5 | 5.5 | V |
| V_{IH} | HIGH-level input voltage | | 2.0 | - | V |
| V_{IL} | LOW-level input voltage | | - | 0.8 | V |
| T_{amb} | ambient temperature | operating in free-air | -40 | +85 | °C |

9. Static characteristics

Table 6. Static characteristics

$T_{amb} = -40$ °C to $+85$ °C.

| Symbol | Parameter | Conditions | Min | Typ ^[1] | Max | Unit |
|-----------------|------------------------------------|---|-----|--------------------|---------|----------|
| V_{IK} | input clamping voltage | $V_{CC} = 4.5$ V; $I_I = -18$ mA | - | - | -1.2 | V |
| V_{pass} | pass voltage | $V_I = V_{CC} = 5.0$ V; $I_O = -100$ μ A | 3.6 | 3.9 | 4.2 | V |
| I_I | input leakage current | $V_{CC} = 5.5$ V; $V_I =$ GND or 5.5 V | - | - | ± 1 | μ A |
| I_{CC} | supply current | $V_{CC} = 5.5$ V; $I_O = 0$ mA; $V_I = V_{CC}$ or GND | - | - | 3 | μ A |
| ΔI_{CC} | additional supply current | per input; $V_{CC} = 5.5$ V; one input at 3.4 V, other inputs at V_{CC} or GND ^[2] | - | - | 2.5 | mA |
| C_I | input capacitance | control pins; $V_I = 3$ V or 0 V | - | 3.3 | - | pF |
| $C_{io(off)}$ | off-state input/output capacitance | A port; $V_O = 3$ V or 0 V; $\overline{OE} = V_{CC}$ | - | 9.9 | - | pF |
| | | B port; $V_O = 3$ V or 0 V; $\overline{OE} = V_{CC}$ | - | 6.4 | - | pF |
| R_{ON} | ON resistance | $V_{CC} = 4.5$ V ^[3] | | | | |
| | | $V_I = 0$ V; $I_I = 64$ mA | - | 5 | 7 | Ω |
| | | $V_I = 0$ V; $I_I = 30$ mA | - | 5 | 7 | Ω |
| | | $V_I = 2.4$ V; $I_I = 15$ mA | - | 10 | 15 | Ω |

[1] All typical values are measured at $V_{CC} = 5$ V; $T_{amb} = 25$ °C.

[2] This is the increase in supply current for each input that is at the specified TTL voltage level rather than V_{CC} or GND.

[3] Measured by the voltage drop between the nA and the nBn terminals at the indicated current through the switch. The lowest voltage of the two (nA or nBn) terminals determines the ON resistance.

10. Dynamic characteristics

Table 7. Dynamic characteristics

$T_{amb} = -40\text{ }^{\circ}\text{C}$ to $+85\text{ }^{\circ}\text{C}$; $V_{CC} = 4.5\text{ V}$ to 5.5 V ; for test circuit see [Figure 7](#).

| Symbol | Parameter | Conditions | Min | Max | Unit |
|-----------|-------------------|--|------------|------|------|
| t_{pd} | propagation delay | nA to nBn or nBn to nA; see Figure 5 | [1][2] - | 0.25 | ns |
| | | S to nA; see Figure 5 | [1][2] 1.4 | 5.0 | ns |
| t_{en} | enable time | \overline{OE} to nA or nBn; see Figure 6 | [2] 1.5 | 5.1 | ns |
| | | S to nBn; see Figure 6 | [2] 1.4 | 5.2 | ns |
| t_{dis} | disable time | \overline{OE} to nA or nBn; see Figure 6 | [2] 2.2 | 5.5 | ns |
| | | S to nBn; see Figure 6 | [2] 1.0 | 5.0 | ns |

[1] This parameter is warranted but not production tested. The propagation delay is based on the RC time constant of the typical ON resistance of the switch and a load capacitance, when driven by an ideal voltage source (zero output impedance).

[2] t_{PLH} and t_{PHL} are the same as t_{pd} .
 t_{PZL} and t_{PZH} are the same as t_{en} .
 t_{PLZ} and t_{PHZ} are the same as t_{dis} .

11. AC waveforms

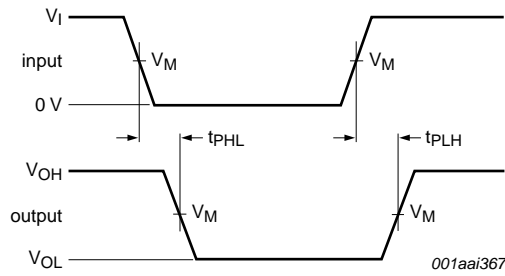

Measurement points are given in [Table 8](#).

V_{OL} and V_{OH} are typical voltage output levels that occur with the output load.

Fig 5. The input (nA; nBn) to output (nBn; nA) or input (S) to output (nA) propagation delay times

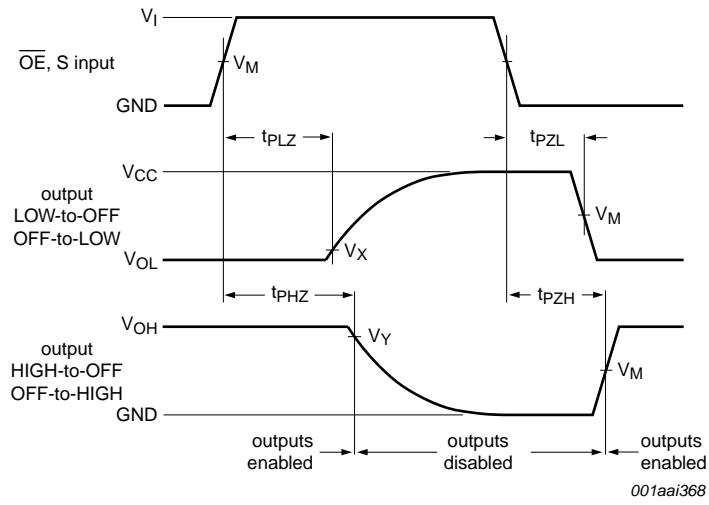

Measurement points are given in [Table 8](#).

V_{OL} and V_{OH} are typical voltage output levels that occur with the output load.

Fig 6. Enable and disable times

Table 8. Measurement points

| Supply voltage | Input | | Output | | |
|----------------|--------------|-------|--------|------------------|------------------|
| V_{CC} | V_I | V_M | V_M | V_X | V_Y |
| 4.5 V to 5.5 V | GND to 3.0 V | 1.5 V | 1.5 V | $V_{OL} + 0.3 V$ | $V_{OH} - 0.3 V$ |

12. Test information

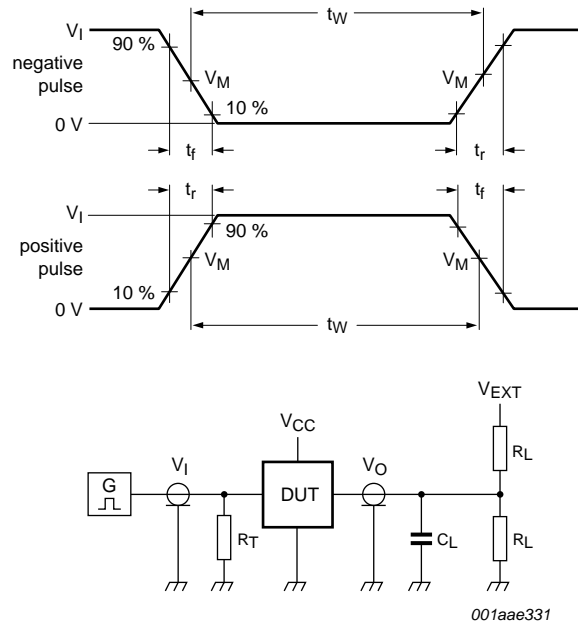

Test data is given in [Table 9](#).

Definitions for test circuit:

R_L = Load resistance.

C_L = Load capacitance including jig and probe capacitance.

R_T = Termination resistance should be equal to the output impedance Z_o of the pulse generator.

V_{EXT} = External voltage for measuring switching times.

Fig 7. Test circuit for measuring switching times

Table 9. Test data

| Supply voltage | Input | | Load | | V_{EXT} | | |
|----------------|--------------|---------------|-------|--------------|--------------------|--------------------|--------------------|
| V_{CC} | V_I | t_r, t_f | C_L | R_L | t_{PLH}, t_{PHL} | t_{PLZ}, t_{PZL} | t_{PHZ}, t_{PZH} |
| 4.5 V to 5.5 V | GND to 3.0 V | ≤ 2.5 ns | 50 pF | 500 Ω | open | 7.0 V | open |

13. Package outline

SO16: plastic small outline package; 16 leads; body width 3.9 mm

SOT109-1

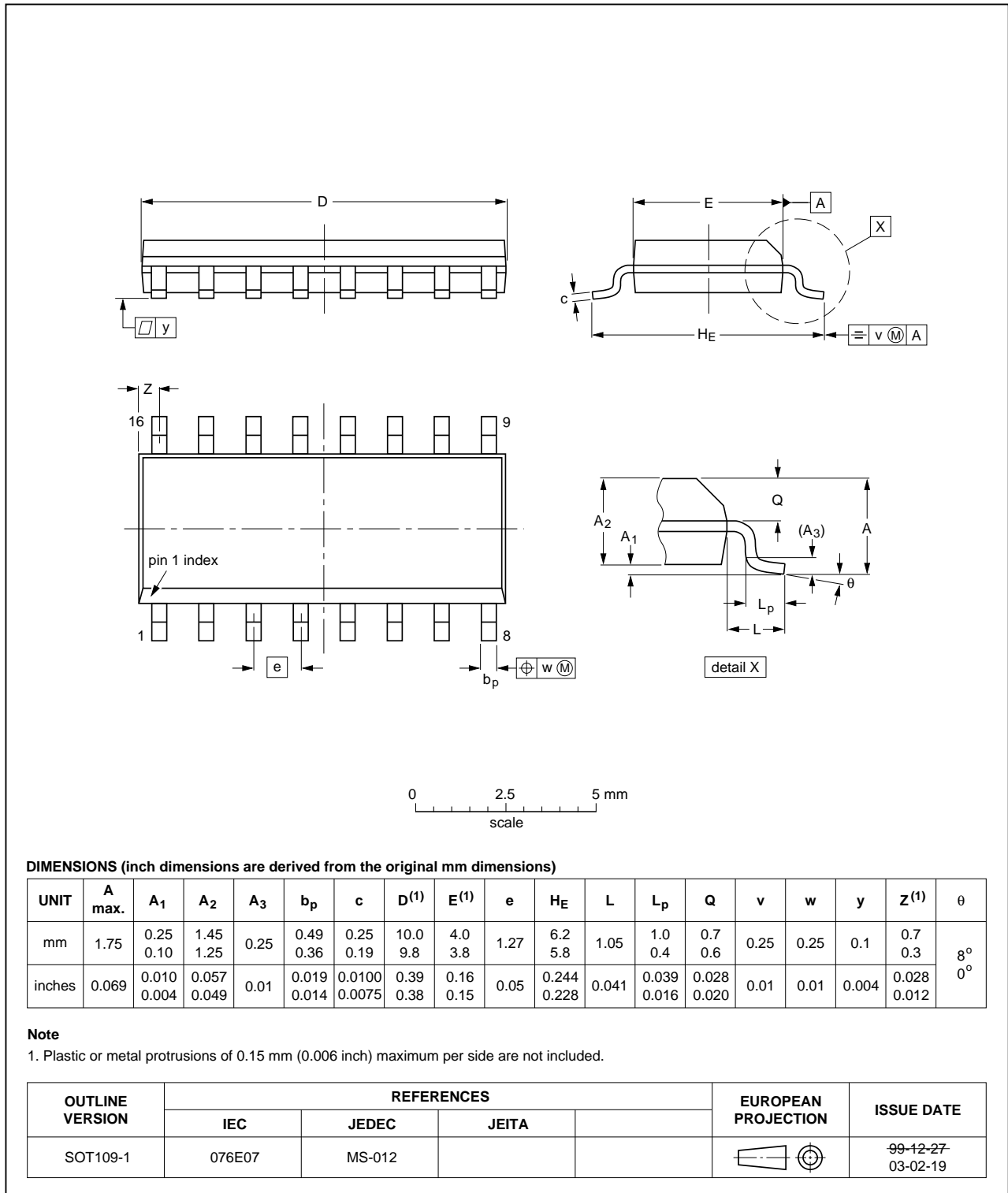

Fig 8. Package outline SOT109-1 (SO16)

SSOP16: plastic shrink small outline package; 16 leads; body width 5.3 mm

SOT338-1

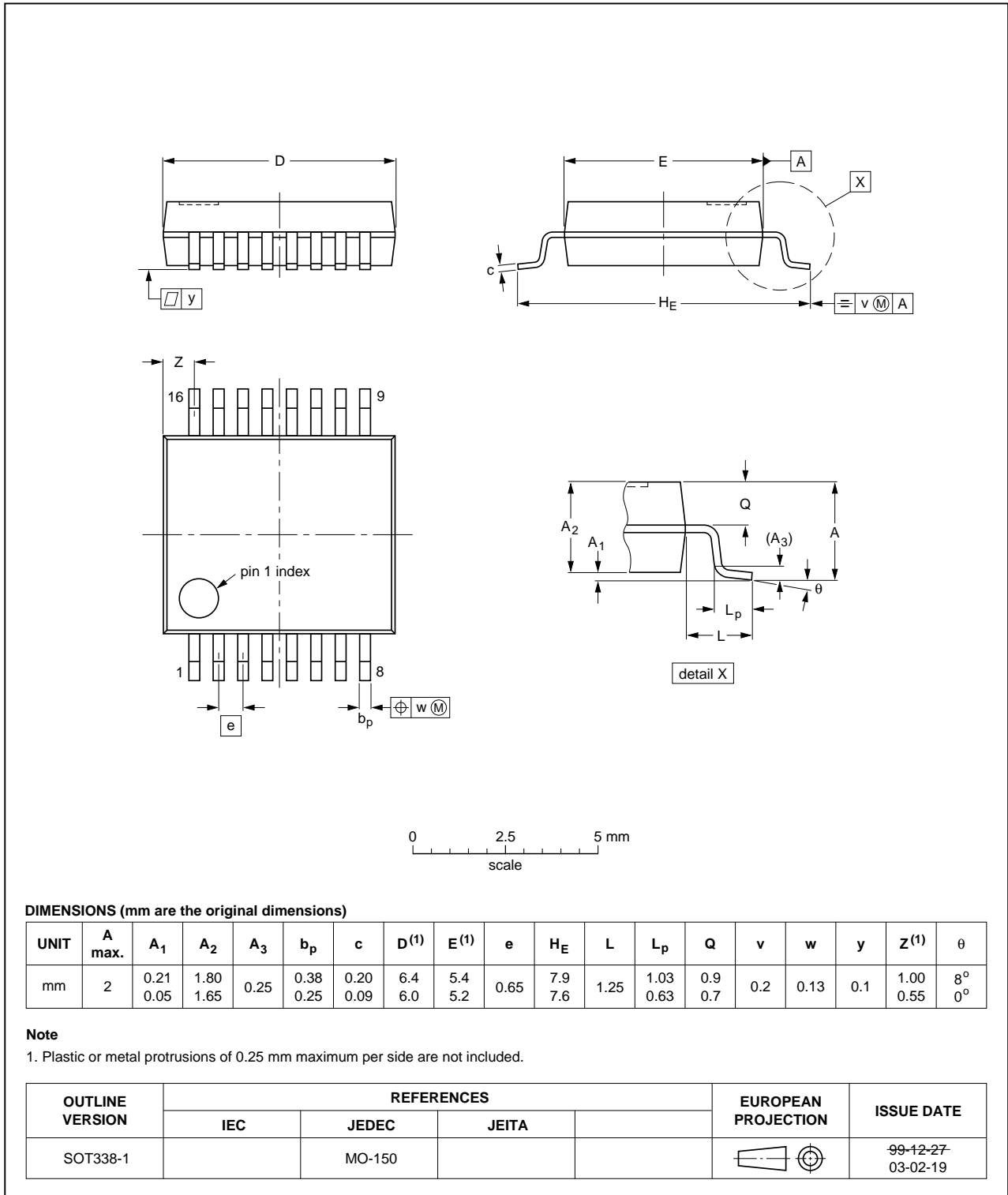

Fig 9. Package outline SOT338-1 (SSOP16)

SSOP16: plastic shrink small outline package; 16 leads; body width 3.9 mm; lead pitch 0.635 mm SOT519-1

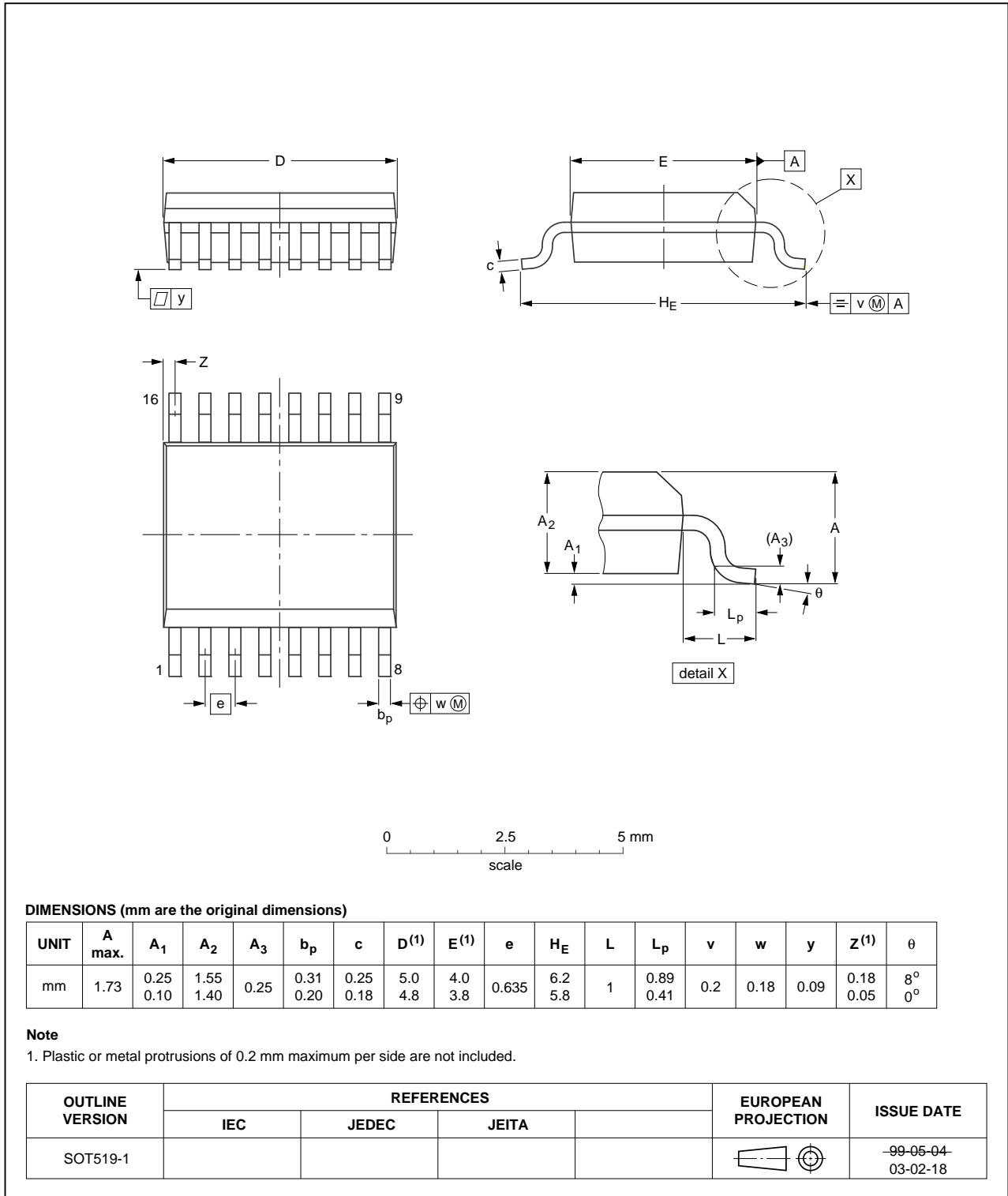

Fig 10. Package outline SOT519-1 (SSOP16)

TSSOP16: plastic thin shrink small outline package; 16 leads; body width 4.4 mm

SOT403-1

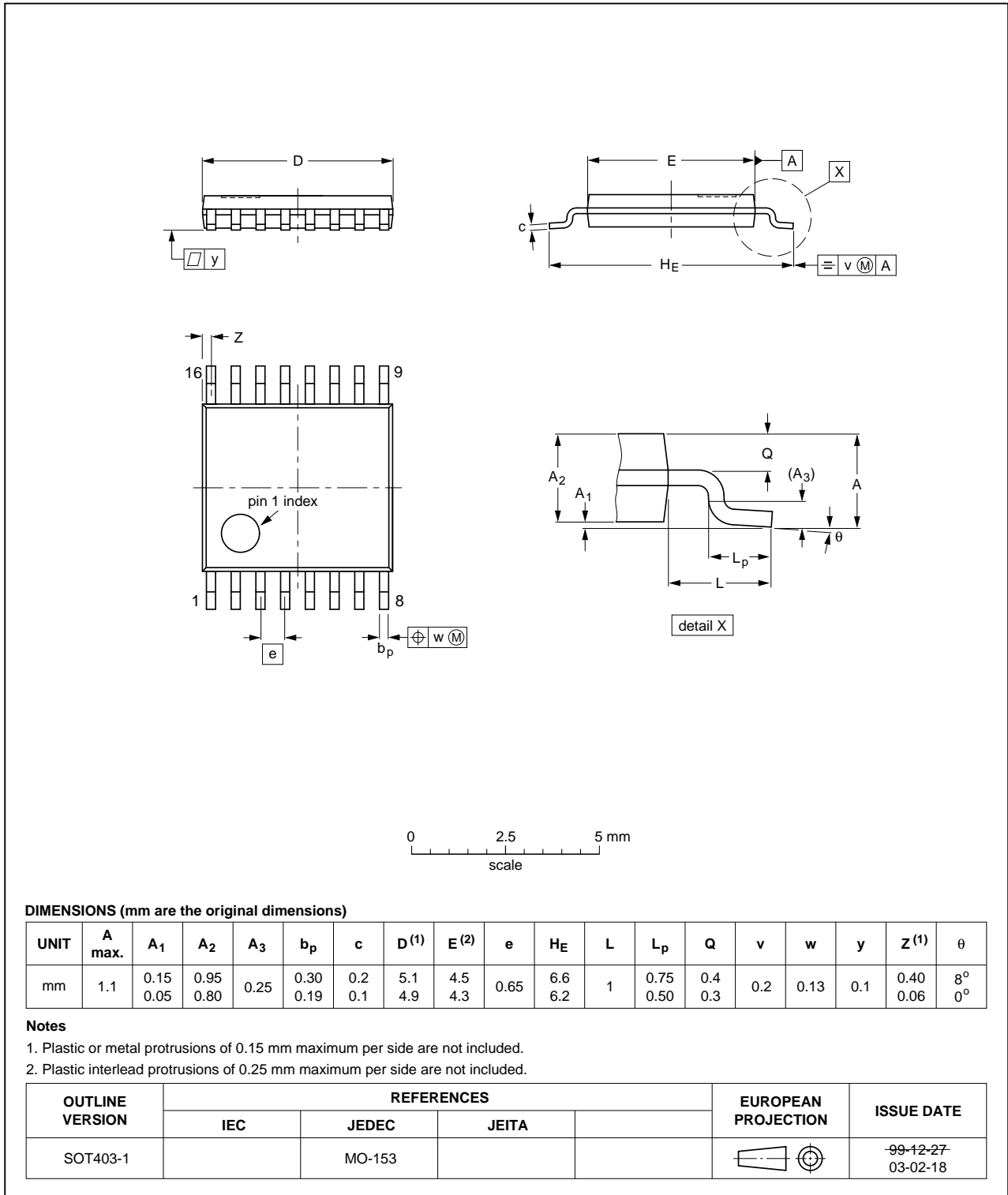

Fig 11. Package outline SOT403-1 (TSSOP16)

DHVQFN16: plastic dual in-line compatible thermal enhanced very thin quad flat package; no leads; 16 terminals; body 2.5 x 3.5 x 0.85 mm

SOT763-1

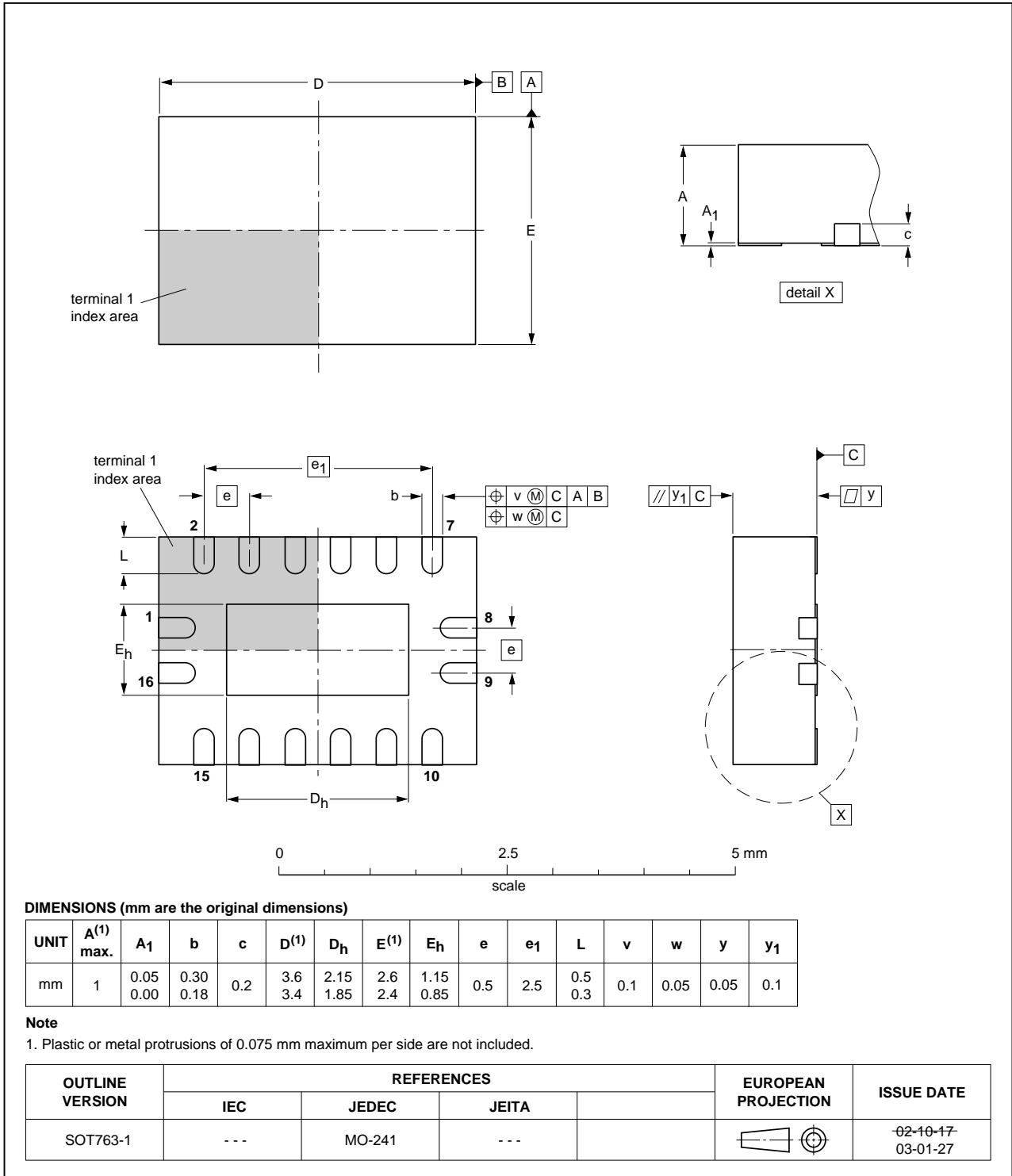

Fig 12. Package outline SOT763-1 (DHVQFN16)

14. Abbreviations

Table 10. Abbreviations

| Acronym | Description |
|---------|-----------------------------|
| CDM | Charged Device Model |
| ESD | ElectroStatic Discharge |
| HBM | Human Body Model |
| MM | Machine Model |
| TTL | Transistor-Transistor Logic |

15. Revision history

Table 11. Revision history

| Document ID | Release date | Data sheet status | Change notice | Supersedes |
|----------------|---|--------------------|---------------|--------------|
| CBT3257A v.5 | 20130404 | Product data sheet | - | CBT3257A v.4 |
| Modifications: | <ul style="list-style-type: none"> • Table 6 "Static characteristics": values for pass voltage modified. | | | |
| CBT3257A v.4 | 20090319 | Product data sheet | - | CBT3257A v.3 |
| CBT3257A v.3 | 20080704 | Product data sheet | - | CBT3257A v.2 |
| CBT3257A v.2 | 20070704 | Product data sheet | - | CBT3257A v.1 |
| CBT3257A v.1 | 20051027 | Product data sheet | - | - |

16. Legal information

16.1 Data sheet status

| Document status ^{[1][2]} | Product status ^[3] | Definition |
|-----------------------------------|-------------------------------|---|
| Objective [short] data sheet | Development | This document contains data from the objective specification for product development. |
| Preliminary [short] data sheet | Qualification | This document contains data from the preliminary specification. |
| Product [short] data sheet | Production | This document contains the product specification. |

[1] Please consult the most recently issued document before initiating or completing a design.

[2] The term 'short data sheet' is explained in section "Definitions".

[3] The product status of device(s) described in this document may have changed since this document was published and may differ in case of multiple devices. The latest product status information is available on the Internet at URL <http://www.nxp.com>.

16.2 Definitions

Draft — The document is a draft version only. The content is still under internal review and subject to formal approval, which may result in modifications or additions. NXP Semiconductors does not give any representations or warranties as to the accuracy or completeness of information included herein and shall have no liability for the consequences of use of such information.

Short data sheet — A short data sheet is an extract from a full data sheet with the same product type number(s) and title. A short data sheet is intended for quick reference only and should not be relied upon to contain detailed and full information. For detailed and full information see the relevant full data sheet, which is available on request via the local NXP Semiconductors sales office. In case of any inconsistency or conflict with the short data sheet, the full data sheet shall prevail.

Product specification — The information and data provided in a Product data sheet shall define the specification of the product as agreed between NXP Semiconductors and its customer, unless NXP Semiconductors and customer have explicitly agreed otherwise in writing. In no event however, shall an agreement be valid in which the NXP Semiconductors product is deemed to offer functions and qualities beyond those described in the Product data sheet.

16.3 Disclaimers

Limited warranty and liability — Information in this document is believed to be accurate and reliable. However, NXP Semiconductors does not give any representations or warranties, expressed or implied, as to the accuracy or completeness of such information and shall have no liability for the consequences of use of such information. NXP Semiconductors takes no responsibility for the content in this document if provided by an information source outside of NXP Semiconductors.

In no event shall NXP Semiconductors be liable for any indirect, incidental, punitive, special or consequential damages (including - without limitation - lost profits, lost savings, business interruption, costs related to the removal or replacement of any products or rework charges) whether or not such damages are based on tort (including negligence), warranty, breach of contract or any other legal theory.

Notwithstanding any damages that customer might incur for any reason whatsoever, NXP Semiconductors' aggregate and cumulative liability towards customer for the products described herein shall be limited in accordance with the *Terms and conditions of commercial sale* of NXP Semiconductors.

Right to make changes — NXP Semiconductors reserves the right to make changes to information published in this document, including without limitation specifications and product descriptions, at any time and without notice. This document supersedes and replaces all information supplied prior to the publication hereof.

Suitability for use — NXP Semiconductors products are not designed, authorized or warranted to be suitable for use in life support, life-critical or safety-critical systems or equipment, nor in applications where failure or malfunction of an NXP Semiconductors product can reasonably be expected to result in personal injury, death or severe property or environmental damage. NXP Semiconductors and its suppliers accept no liability for inclusion and/or use of NXP Semiconductors products in such equipment or applications and therefore such inclusion and/or use is at the customer's own risk.

Applications — Applications that are described herein for any of these products are for illustrative purposes only. NXP Semiconductors makes no representation or warranty that such applications will be suitable for the specified use without further testing or modification.

Customers are responsible for the design and operation of their applications and products using NXP Semiconductors products, and NXP Semiconductors accepts no liability for any assistance with applications or customer product design. It is customer's sole responsibility to determine whether the NXP Semiconductors product is suitable and fit for the customer's applications and products planned, as well as for the planned application and use of customer's third party customer(s). Customers should provide appropriate design and operating safeguards to minimize the risks associated with their applications and products.

NXP Semiconductors does not accept any liability related to any default, damage, costs or problem which is based on any weakness or default in the customer's applications or products, or the application or use by customer's third party customer(s). Customer is responsible for doing all necessary testing for the customer's applications and products using NXP Semiconductors products in order to avoid a default of the applications and the products or of the application or use by customer's third party customer(s). NXP does not accept any liability in this respect.

Limiting values — Stress above one or more limiting values (as defined in the Absolute Maximum Ratings System of IEC 60134) will cause permanent damage to the device. Limiting values are stress ratings only and (proper) operation of the device at these or any other conditions above those given in the Recommended operating conditions section (if present) or the Characteristics sections of this document is not warranted. Constant or repeated exposure to limiting values will permanently and irreversibly affect the quality and reliability of the device.

Terms and conditions of commercial sale — NXP Semiconductors products are sold subject to the general terms and conditions of commercial sale, as published at <http://www.nxp.com/profile/terms>, unless otherwise agreed in a valid written individual agreement. In case an individual agreement is concluded only the terms and conditions of the respective agreement shall apply. NXP Semiconductors hereby expressly objects to applying the customer's general terms and conditions with regard to the purchase of NXP Semiconductors products by customer.

No offer to sell or license — Nothing in this document may be interpreted or construed as an offer to sell products that is open for acceptance or the grant, conveyance or implication of any license under any copyrights, patents or other industrial or intellectual property rights.

Export control — This document as well as the item(s) described herein may be subject to export control regulations. Export might require a prior authorization from competent authorities.

Non-automotive qualified products — Unless this data sheet expressly states that this specific NXP Semiconductors product is automotive qualified, the product is not suitable for automotive use. It is neither qualified nor tested in accordance with automotive testing or application requirements. NXP Semiconductors accepts no liability for inclusion and/or use of non-automotive qualified products in automotive equipment or applications.

In the event that customer uses the product for design-in and use in automotive applications to automotive specifications and standards, customer (a) shall use the product without NXP Semiconductors' warranty of the product for such automotive applications, use and specifications, and (b) whenever customer uses the product for automotive applications beyond

NXP Semiconductors' specifications such use shall be solely at customer's own risk, and (c) customer fully indemnifies NXP Semiconductors for any liability, damages or failed product claims resulting from customer design and use of the product for automotive applications beyond NXP Semiconductors' standard warranty and NXP Semiconductors' product specifications.

Translations — A non-English (translated) version of a document is for reference only. The English version shall prevail in case of any discrepancy between the translated and English versions.

16.4 Trademarks

Notice: All referenced brands, product names, service names and trademarks are the property of their respective owners.

17. Contact information

For more information, please visit: <http://www.nxp.com>

For sales office addresses, please send an email to: salesaddresses@nxp.com

18. Contents

| | | |
|-----------|---|-----------|
| 1 | General description | 1 |
| 2 | Features and benefits | 1 |
| 3 | Ordering information | 2 |
| 4 | Functional diagram | 2 |
| 5 | Pinning information | 3 |
| 5.1 | Pinning | 3 |
| 5.2 | Pin description | 4 |
| 6 | Functional description | 4 |
| 7 | Limiting values | 4 |
| 8 | Recommended operating conditions | 5 |
| 9 | Static characteristics | 5 |
| 10 | Dynamic characteristics | 6 |
| 11 | AC waveforms | 6 |
| 12 | Test information | 8 |
| 13 | Package outline | 9 |
| 14 | Abbreviations | 14 |
| 15 | Revision history | 14 |
| 16 | Legal information | 15 |
| 16.1 | Data sheet status | 15 |
| 16.2 | Definitions | 15 |
| 16.3 | Disclaimers | 15 |
| 16.4 | Trademarks | 16 |
| 17 | Contact information | 16 |
| 18 | Contents | 17 |

Please be aware that important notices concerning this document and the product(s) described herein, have been included in section 'Legal information'.

© NXP B.V. 2013.

All rights reserved.

For more information, please visit: <http://www.nxp.com>

For sales office addresses, please send an email to: salesaddresses@nxp.com

Date of release: 4 April 2013

Document identifier: CBT3257A