

PART NUMBER	REV	FIRST USED	POWER UNIT	FEED TYPE
1855323-1	C	122500-1	LEADMAKER & BENCH MODEL G	AIR FEED
1855323-2	C	565435-5	BENCH MODEL K	AIR FEED
7-1855323-7	A	-	SPARE PARTS	-

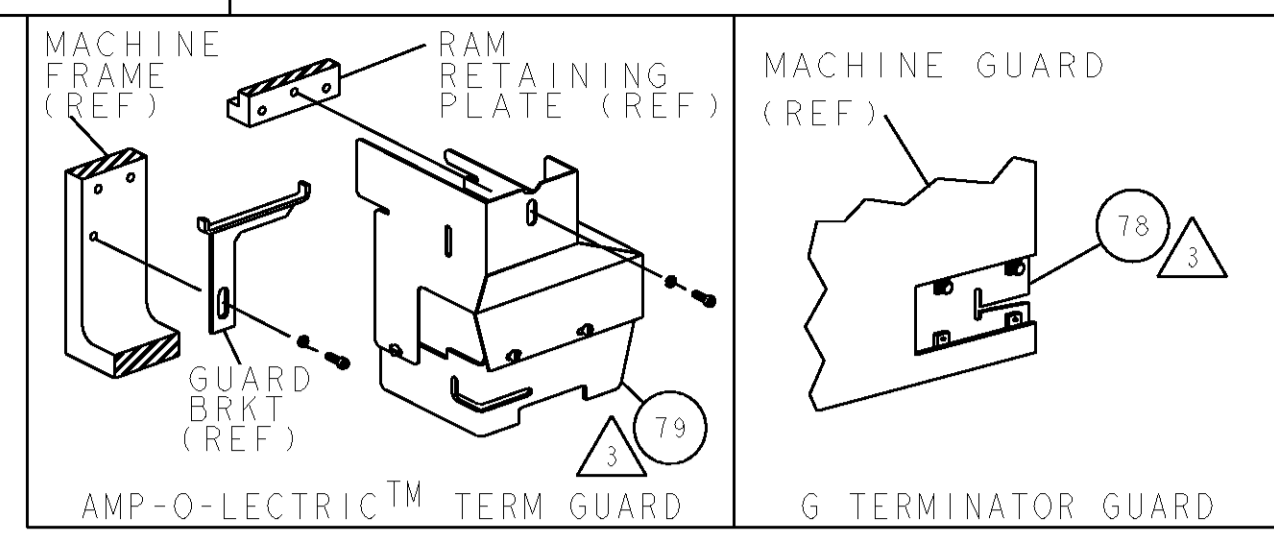

TE PN		COMP PN		G & H TERMINAL - AMP CRIMP SPECS			
1949484	25209.213.011						
				CRIMP HEIGHT	WIRE SIZE	REF SETTING*	
				1.83+0.10/-0.05mm [.072+ .004/- .002]	18 AWG	C2	
				1.75+0.10/-0.05mm [.069+ .004/- .002]	20 AWG	C9	
				-	-	-	
				-	-	-	
				CRIMP	SIZE	TYPE	RANGE
				WIRE	2.79mm [.110]	F	18-20 AWG
				INSUL	4.06mm [.160]	F	-
WIRE STRIP LENGTH	TERM APPL SPEC	FEED	APPL INSTRUCTIONS	SET UP GAGE			
5.66mm-6.05mm	NONE	30.10mm	408-8039	458638-1			

LOC	DIST	REV	DESCRIPTION	DATE	BY	APPV
A	66					
B			EC 08-016278	25JUN2008	CMR	CMR
C			ECR-08-016063	09JUL2008	MY	GB

- △ RECOMMENDED SPARE PARTS
- △ GREASE LIGHTLY
- △ GUARD MUST BE IN PLACE WHEN OPERATING APPLICATOR IN A BENCH MACHINE

***WARNING:**
ON INSTALLATION, SET WIRE DISC TO LARGEST WIRE SIZE SETTING. USE OF SETTINGS BELOW MIN REQUIRED CRIMP HEIGHT SETTING WILL CAUSE DAMAGE TO CRIMP TOOLING.

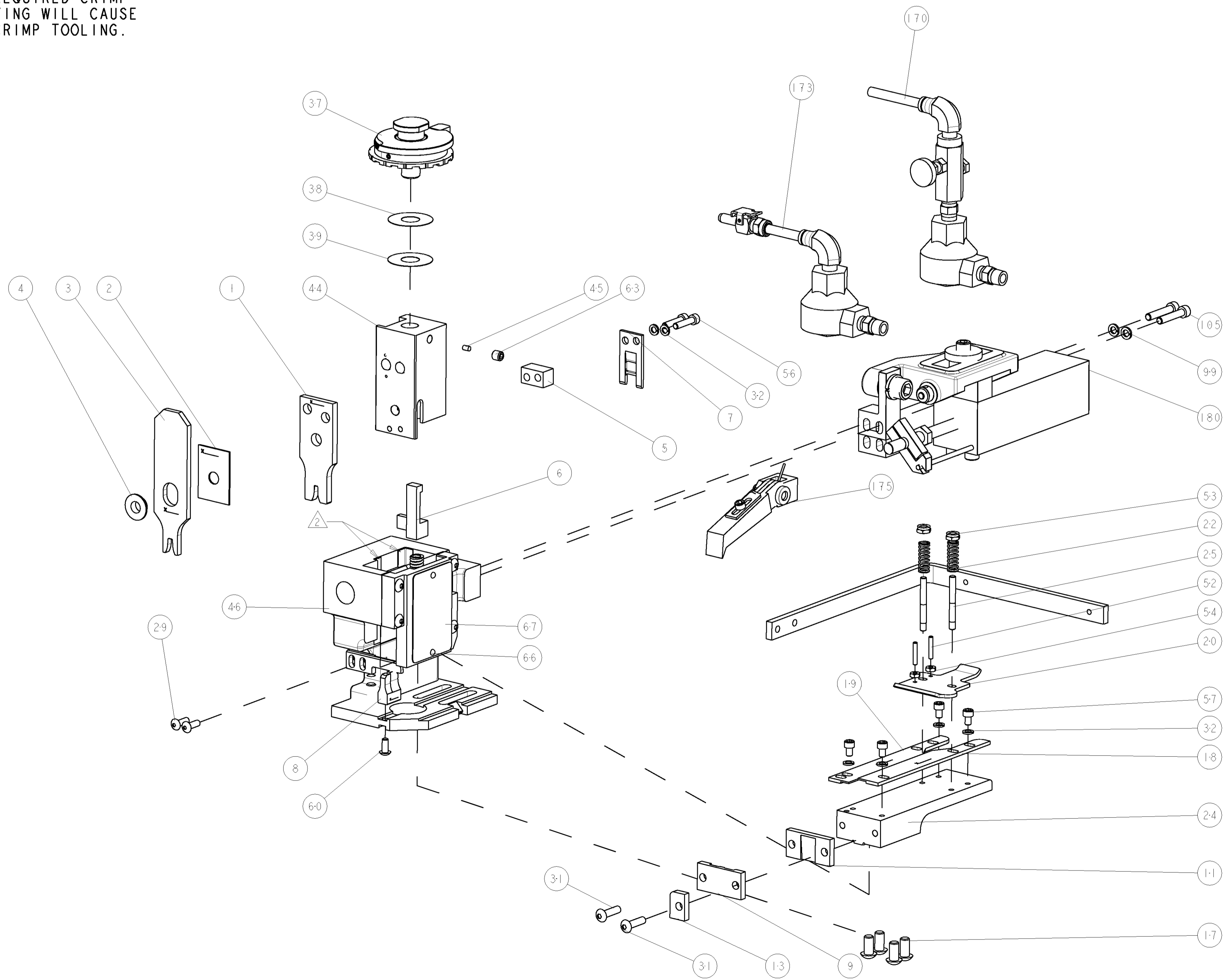

-	1	1	-	2-460277-7	AIR FEED ASSY	180
-	1	1	-	460680-1	FEED FINGER ASSEMBLY	175
-	-	1	-	692655-7	AIR FEED VALVE ASSEMBLY	173
-	1	-	-	692655-5	AIR FEED VALVE ASSEMBLY	170
-	1	1	-	1-460277-5	AIR FEED ASSY	169
-	2	2	-	3-21000-9	SCR, SKT HD CAP 10-32 X 1.000	105
-	2	2	-	21024-5	WASHER, SPRG LOCK, REG NO 10	99
-	REF	-	-	455745-1	GUARD WINDOW	79
-	-	REF	-	679532-1	INSERT, GUARD	78
-	1	1	-	217238-1	GENERAL INSTRUCTION PKG	72
-	1	1	-	4088039	EF APPL INST 408-8039	71
-	1	1	-	461264-5	PLATE, IDENTIFICATION	67
-	2	2	-	21017-2	SCREW, DRIVE	66
-	1	1	-	21009-2	SCR, SET, SELF LOCKING 1/4-20 X .250	63
-	1	1	-	22733-8	SCR, BHSC, SELF-LOCKING, 8-32 X .375	60
-	4	4	-	2-21000-5	SCR, SKT HD CAP 8-32 X .250	57
-	2	2	-	2-21000-9	SCR, SKT HD CAP 8-32 X .750	56
-	2	2	-	21018-4	NUT, HEX, REG 4-40	54
-	2	2	-	21022-2	NUT, LOCK, HEX, TORQUE, 8-32	53
-	2	2	-	2-21006-6	SCR, SET, CUP POINT 4-40 X .625	52
-	1	1	-	1633570-2	SUB ASSY, APPLICATOR FRAME	46
-	1	1	-	690191-1	PLUG, NYLON	45
-	1	1	-	455674-1	RAM	44
-	1	1	-	7-21002-9	SCR, BTN SKT HD CAP 5/16-24 X 1.00	41
-	1	1	-	690125-1	SHIM SUB-ASSY	39
-	1	1	-	469367-1	SHIM	38
-	1	1	-	879103-2	FINE ADJUST HEAD ASSEMBLY	37
-	6	6	-	21024-4	WASHER, SPRG LOCK, REG NO 8	32
-	2	2	-	2-21002-9	SCR, BTN SKT HD CAP 10-32 X .750	31
-	2	2	-	2-21002-2	SCR, BTN SKT HD CAP 8-32 X .500	29
-	1	1	-	1-690451-7	SPACER, STRIPPER	28
-	1	1	-	240639-1	STRIPPER (MACHINING)	27
-	2	2	-	22354-8	STUD, THREADED	25
-	1	1	-	455678-1	PLATE, STRIP GUIDE	24
-	2	2	-	4-22281-1	SPRING, COMPRESSION	22
-	1	1	-	454177-1	DRAG	20
-	1	1	-	2-458030-3	STRIP GUIDE, REAR	19
-	1	1	-	2-458031-3	STRIP GUIDE, FRONT	18
-	4	4	-	3-21002-3	SCR, BTN SKT HD CAP 1/4-20 X .500	17
-	1	1	-	690481-2	SPACER, HOLD DOWN	13
-	1	1	-	8-22282-9	SPRING, DIE	12
-	1	1	-	240644-1	PLATE, REAR SHEAR	11
-	-	-	-	-	-	10
-	1	1	-	690482-4	PLATE, FRONT SHEAR	9
-	1	1	-	1-1633248-7	ANVIL, COMBINATION	8
-	1	1	-	690474-4	BLADE, SLUG	7
-	1	1	-	6-455892-1	HOLD DOWN, TERMINAL	6
-	1	1	-	7-240641-7	SPACER	5
-	1	1	-	238009-3	BLOCK, FL CRIMPER SPACER	4
-	1	1	-	8-1213077-3	CRIMPER, INSULATION PREMIUM	3
-	1	1	-	455888-8	SPACER, CRIMPER	2
-	1	1	-	456408-9	CRIMPER, WIRE PREMIUM	1

DIMENSIONS: INCHES 		TOLERANCES UNLESS OTHERWISE SPECIFIED: 0 PLC ± 1 PLC ±0.1 2 PLC ±0.01 3 PLC ±0.001 4 PLC ±0.0001 ANGLES ±		DWN: C. REICHELDERFER CHK: T. ELBIN APVD: J. BENCHOFF DATE: 15OCT2007 NAME: FINE ADJUST END FEED HDM APPLICATOR		Tyco Electronics Harrisburg, PA 17105-3608	
MATERIAL:		FINISH:		WEIGHT:		SCALE: 3:5 SHEET 1 OF 1 REV C	
CUSTOMER DRAWING		CUSTOMER DRAWING		CUSTOMER DRAWING		CUSTOMER VIEWABLE ASSEMBLY	