

PART NUMBER	REVISION	DESCRIPTION	FEED TYPE
2266335-1	E	FINE CRIMP HEIGHT ADJUST	MECHANICAL
2266335-2	E	FINE CRIMP HEIGHT ADJUST	PNEUMATIC
7-2266335-1	E	MECHANICAL AND CRIMP TOOLING KIT	MECHANICAL
7-2266335-2	E	PNEUMATIC AND CRIMP TOOLING KIT	PNEUMATIC
7-2266335-7	A	CRIMP TOOLING KIT	-

ATLANTIC VERSION TERMINATOR
INTERFACE ADAPTER

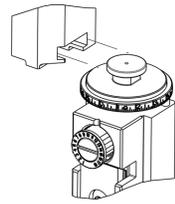

APPLICATOR DATA		
CRIMP	SIZE	TYPE
WIRE	1.40 mm [.055]	F
INSUL	1.78 mm [.070]	O

APPLICATOR INSTRUCTIONS
408-35042

TERMINAL DATA: TE TERMINAL		TE CRIMP SPECIFICATION	
TERMINAL NAME: PIN ASSEMBLY, .062, TYPE III+			
WIRE STRIP LENGTH		INSULATION DIAMETER RANGE	
3.58-4.34 mm [.141-.171 IN]		Ø0.89-1.40 mm [.035-.055 IN]	
TERMINAL APPLICATION SPECIFICATION	(A)114-10004		
	(B)114-19000		
TERMINALS APPLIED			
TE TERMINAL	TE TERMINAL	TE TERMINAL	TE TERMINAL
(A) 66106-5	(A) 1-66106-5	(B) 164159-3	(B) 164159-7
(A) 66106-7	(B) 163089-9	(B) 164159-4	(A) 170249-2
(A) 66106-8	(B) 1-163089-1		

TERMINAL DATA: TE TERMINAL		TE CRIMP SPECIFICATION	
TERMINAL NAME: SOCKET ASSEMBLY, .062, TYPE III+			
WIRE STRIP LENGTH		INSULATION DIAMETER RANGE	
3.58-4.34 mm [.141-.171 IN]		Ø0.89-1.40 mm [.035-.055 IN]	
TERMINAL APPLICATION SPECIFICATION	(A)114-10004		
	(B)114-19000		
TERMINALS APPLIED			
TE TERMINAL	TE TERMINAL	TE TERMINAL	TE TERMINAL
(A) 66108-5	(A) 66108-8	(B) 163091-7	(B) 1-163091-1
(A) 66108-6	(A) 1-66108-5	(B) 163091-8	(B) 1-163091-3
(A) 66108-7	(B) 163091-6	(B) 163091-9	

WIRE SIZE	CRIMP HEIGHT mm [INCH]	CRIMP HEIGHT REFERENCE SETTING
24 AWG	0.84 +/- 0.05 [.033 +/- .002]	6.0
26 AWG	0.79 +/- 0.05 [.031 +/- .002]	6.5

- 1. RECOMMENDED SPARE PARTS
- 2. REFER TO SUPPLIED INSTRUCTION SHEET FOR CLEANING, LUBRICATION AND STORAGE OF APPLICATOR.
- 3. APPLY PART NUMBER 2-23419-6 LOCTITE TO THREADS OF ITEM 242.
- 4. CRIMP HEIGHT REFERENCE SETTING WAS THE SETTING USED WHEN THE APPLICATOR WAS QUALIFIED AT THE FACTORY. ADJUSTMENT MAY BE NECESSARY WHEN RUNNING APPLICATOR IN THE FIELD.
- 5. UNLESS SPECIFIED OTHERWISE TORQUE VALUES SHALL BE USED PER DOCUMENT, 101-35000.

***WARNING**
ON INSTALLATION, SET WIRE DISC TO CRIMP HEIGHT REFERENCE SETTING FOR LARGEST WIRE SIZE. CRIMP HEIGHT REFERENCE SETTINGS GREATER THAN THE VALUE SHOWN MAY CAUSE DAMAGE TO THE CRIMP TOOLING, REFER TO THE INSTRUCTION SHEET FOR PROPER SETUP AND ADJUSTMENTS.

ATLANTIC VERSION
Shown on sheets 1 of 4 & 2 of 4
(Pacific version shown on sheets 3 of 4 & 4 of 4)

LOC	DIST	REVISIONS			
A	66	REV	DATE	BY	CHKD
		C2	13FEB2018	YY	JDG
		D	30MAY2018	KH	JDG
		D1	11DEC2019	FZ	RR
		E	03SEP2020	MEH	RR

-	1	-	1	-	2119641-1	FEED CAM, AIR FEED	248	
-	1	1	1	1	2119082-5	CAM, SNAIL, INSULATION ADJUSTMENT	244	
-	1	1	1	1	2079764-1	WASHER, WAVE SPRING, CREST-TO-CREST	243	
-	1	1	1	1	2119083-1	RETAINER, INSULATION DIAL	242	
-	1	1	1	1	7-18023-7	SCR, SKT HD CAP M3 X 4.0	241	
-	-	1	-	1	2119580-1	MECHANICAL FEED ASSEMBLY	239	
-	1	-	1	-	2844940-1	AIR FEED MODULE	238	
-	REF	REF	REF	REF	994970-2	COUNTER, MAGNETIC	164	
-	1	1	1	1	2844908-1	SCREW, LOCKING	99	
-	1	1	1	1	2844907-1	POST, LOCKING	98	
-	1	1	1	1	455888-4	SPACER, CRIMPER	82	
-	1	1	1	1	1803607-3	DOCUMENTATION PACKAGE	71	
-	1	1	1	1	2119791-9	DEPRESSOR, WIRE	70	
-	1	1	1	1	2119943-1	WASHER, SPACER	69	
-	1	1	1	1	2119740-1	TAG, IDENTIFICATION	67	
-	2	2	2	2	2168078-1	SCREW, DRIVE, RH, RoHS, 2 x .188	66	
-	1	1	1	1	2168083-2	SCR, SKT HD CAP, RoHS, M4 X 8.0	60	
-	1	1	1	1	5-18022-5	SCR, HEX HD CAP, M4 X 6.0	59	
-	1	1	1	1	1338685-1	PAWL, FEED	56	
-	4	4	4	4	2168083-3	SCR, SKT HD CAP, RoHS, M4 X 12.0	54	
-	2	2	2	2	2-2168083-5	SCR, SKT HD CAP, RoHS, M4 X 14	53	
-	1	1	1	1	1803382-6	HOLD DOWN, SPRING LOADED	50	
-	1	2	1	2	18023-9	SCR, SKT HD CAP M4 X 6.0	49	
-	-	1	-	1	2119652-1	FEED CAM, PRE FEED	48	
-	-	1	-	1	2119653-1	FEED CAM, POST FEED	47	
-	1	1	1	1	1803583-9	APPLICATOR BASIC ASSEMBLY, SF	46	
-	1	1	1	1	1803515-1	RAM ASSEMBLY, SF ATLANTIC	44	
-	1	1	1	1	1803602-1	SCR, BHSC, RoHS (M8 X 25)	41	
-	1	1	1	1	1752356-1	SUPPORT, TERMINAL	34	
-	2	2	2	2	2079383-5	SCR, BHSC, RoHS (M4 X 20)	33	
-	2	2	2	2	2-2844962-4	SPACER, CYLINDRICAL, STRIP GUIDE	30	
-	1	1	1	1	2844992-1	ASSEMBLY, STRIP GUIDE	29	
-	1	1	1	1	455888-3	SPACER, CRIMPER	28	
-	1	1	1	1	1320928-6	STRIP GUIDE	24	
-	1	1	1	1	2168083-2	SCR, SKT HD CAP, RoHS, M4 X 8.0	21	
-	2	2	2	2	1-18028-2	WASHER, FLAT, REG M4	20	
-	1	1	1	1	2119533-1	STRIPPER, SIDE FEED	19	
-	1	1	1	1	2119806-1	INSERT, SHEAR	13	
-	1	1	1	1	3-22280-3	SPRING, COMPRESSION	12	
-	1	1	1	1	1-356885-4	STOP, SHEAR	11	
-	1	1	1	1	2119805-1	SHEAR HOLDER, FRONT	10	
-	1	1	1	1	1803095-3	FLOATING SHEAR, FRONT	9	
-	1	2	2	1	1	2-1633917-6	ANVIL, COMBINATION	8
-	1	1	1	1	240641-5	SPACER	7	
-	-	-	-	-	-	-	6	
-	1	1	1	1	2119757-1	DEPRESSOR, SHEAR	5	
-	1	1	1	1	2-238011-2	BLOCK, CRIMPER SPACER	4	
-	1	2	2	1	1	3-1633966-0	CRIMPER, INSULATION O	3
-	1	1	1	1	455888-3	SPACER, CRIMPER	2	
-	1	2	2	1	1	1-456402-4	CRIMPER, WIRE PREMIUM	1
-	77	-72	-71	-2	-1	PART NO	DESCRIPTION	ITEM NO

DIMENSIONS:		TOLERANCES UNLESS OTHERWISE SPECIFIED:		MATERIAL:	
mm	0 PLC ±	1 PLC ±	2 PLC ±	3 PLC ±	4 PLC ±
	ANGLES	FINISH			

OWN	HOFFNER	13JUNE2014
CHK	T. ELBIN	16JUNE2014
APVD	T. ELBIN	16JUNE2014
NAME	Ocean Side Feed Applicator	
SIZE	CAGE CODE	DRAWING NO
A1	00779	2266335
Customer Accessible Production Drawing		SCALE 1:2 SHEET 1 OF 4 REV E

LOC	DIST	REVISIONS			
A	66	REV	DATE	OWN	APVD
-	-	SEE SHEET 1	-	-	-

FEED TYPE MECHANICAL

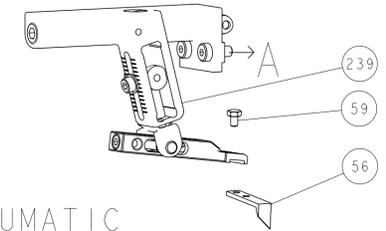

PNEUMATIC

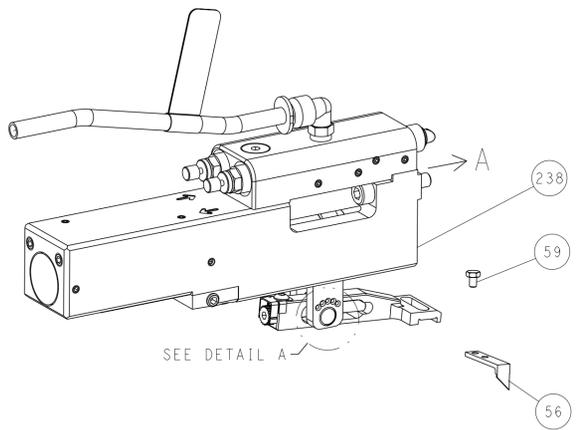

FEED SPRING SETTING POSITION (SHOWN FROM REAR SIDE)

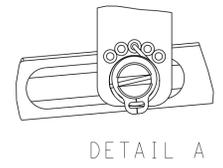

DETAIL A

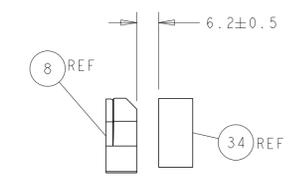
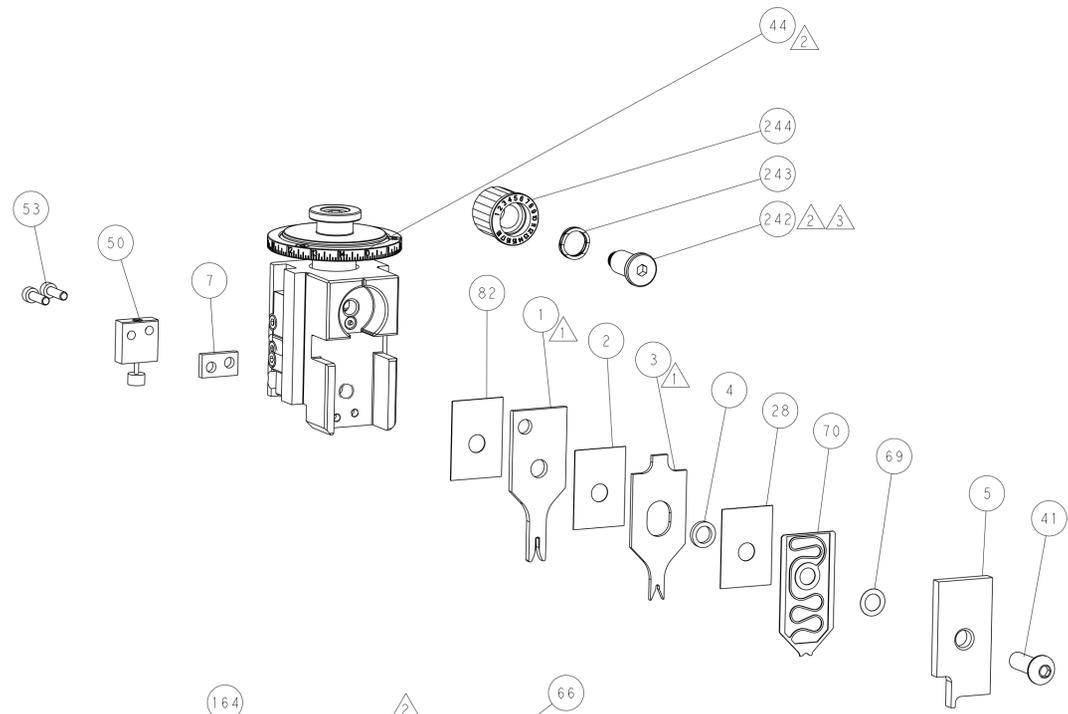
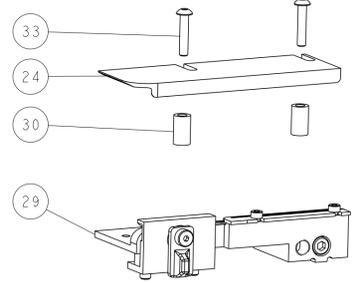

TERMINAL SUPPORT LOCATION

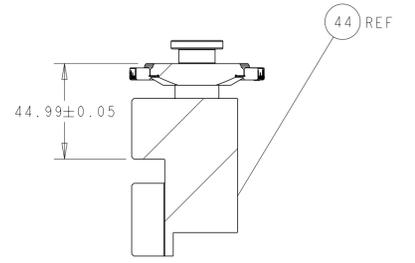

RAM SET-UP

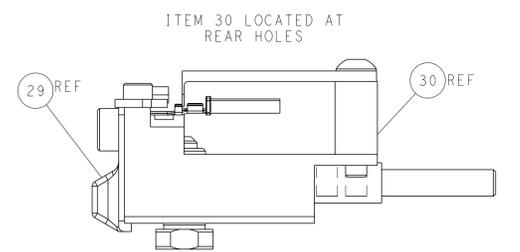

FEED TRACK POSITION GUIDE BY INSULATION BARREL

CAM POSITIONS

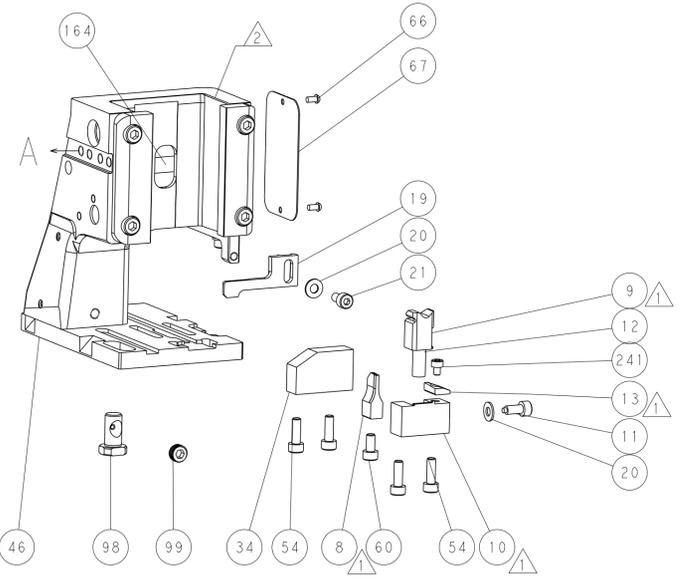
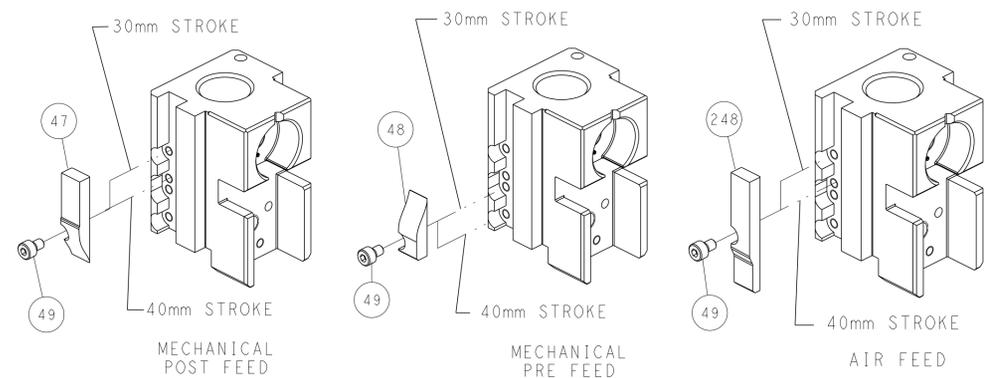

ATLANTIC VERSION
 Shown on sheets 1 of 4 & 2 of 4
 (Pacific version shown on sheets 3 of 4 & 4 of 4)

<small>THIS DRAWING IS A CONTROLLED DOCUMENT FOR TYCO ELECTRONICS CORPORATION. IT IS SUBJECT TO CHANGE AND THE CONTROL AND RESTRICTION DESIGNATION SHOULD BE CONTACTED FOR THE LATEST REVISION.</small>		OWN: HOFFNER CHK: T. ELBIN APVD: T. ELBIN PRODUCT SPEC: - APPLICATION SPEC: - WEIGHT: - MATERIAL: -	DATE: 13JUNE2014 DATE: 16JUNE2014 DATE: 16JUNE2014 SCALE: 1:2 SHEET: 2 of 4 REV: E	NAME: Ocean Side Feed Applicator SIZE: A1 CAGE CODE: 00779 DRAWING NO: C=2266335 RESTRICTED TO: -
---	--	---	---	---

THIS DRAWING IS UNPUBLISHED.	RELEASED FOR PUBLICATION		
COPYRIGHT 20 BY TYCO ELECTRONICS CORPORATION. ALL RIGHTS RESERVED.			
PART NUMBER	REVISION	DESCRIPTION	FEED TYPE
2-2266335-1	E	FINE CRIMP HEIGHT ADJUST	MECHANICAL
2-2266335-2	E	FINE CRIMP HEIGHT ADJUST	PNEUMATIC
7-2266335-7	A	CRIMP TOOLING KIT	-

PACIFIC VERSION TERMINATOR
INTERFACE ADAPTER

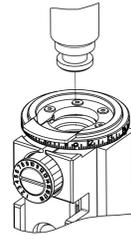

APPLICATOR DATA		
CRIMP	SIZE	TYPE
WIRE	1.40 mm [.055]	F
INSUL	1.78 mm [.070]	O
APPLICATOR INSTRUCTIONS 408-35042		

TERMINAL DATA: TE TERMINAL		TE CRIMP SPECIFICATION	
TERMINAL NAME: PIN ASSEMBLY, .062, TYPE III+			
WIRE STRIP LENGTH		INSULATION DIAMETER RANGE	
3.58-4.34 mm [.141-.171 IN]		Ø0.89-1.40 mm [.035-.055 IN]	
TERMINAL APPLICATION SPECIFICATION	(A)114-10004	-	-
	(B)114-19000	-	-
TERMINALS APPLIED			
TE TERMINAL	TE TERMINAL	TE TERMINAL	TE TERMINAL
(A) 66106-5	(A) 1-66106-5	(B) 164159-3	(B) 164159-7
(A) 66106-7	(B) 163089-9	(B) 164159-4	(A) 170249-2
(A) 66106-8	(B) 1-163089-1		

TERMINAL DATA: TE TERMINAL		TE CRIMP SPECIFICATION	
TERMINAL NAME: SOCKET ASSEMBLY, .062, TYPE III+			
WIRE STRIP LENGTH		INSULATION DIAMETER RANGE	
3.58-4.34 mm [.141-.171 IN]		Ø0.89-1.40 mm [.035-.055 IN]	
TERMINAL APPLICATION SPECIFICATION	(A)114-10004	-	-
	(B)114-19000	-	-
TERMINALS APPLIED			
TE TERMINAL	TE TERMINAL	TE TERMINAL	TE TERMINAL
(A) 66108-5	(A) 66108-8	(B) 163091-7	(B) 1-163091-1
(A) 66108-6	(A) 1-66108-5	(B) 163091-8	(B) 1-163091-3
(A) 66108-7	(B) 163091-6	(B) 163091-9	

WIRE SIZE	CRIMP HEIGHT mm [INCH]	CRIMP HEIGHT REFERENCE SETTING
24 AWG	0.84+/-0.05 [.033+/-0.002]	6.0
26 AWG	0.79+/-0.05 [.031+/-0.002]	6.5

- RECOMMENDED SPARE PARTS
- REFER TO SUPPLIED INSTRUCTION SHEET FOR CLEANING, LUBRICATION AND STORAGE OF APPLICATOR.
- APPLY PART NUMBER 2-23419-6 LOCTITE TO THREADS OF ITEM 242.
- CRIMP HEIGHT REFERENCE SETTING WAS THE SETTING USED WHEN THE APPLICATOR WAS QUALIFIED AT THE FACTORY. ADJUSTMENT MAY BE NECESSARY WHEN RUNNING APPLICATOR IN THE FIELD.
- 5. UNLESS SPECIFIED OTHERWISE TORQUE VALUES SHALL BE USED PER DOCUMENT, 101-35000.

***WARNING**
ON INSTALLATION, SET WIRE DISC TO CRIMP HEIGHT REFERENCE SETTING FOR LARGEST WIRE SIZE. CRIMP HEIGHT REFERENCE SETTINGS GREATER THAN THE VALUE SHOWN MAY CAUSE DAMAGE TO THE CRIMP TOOLING, REFER TO THE INSTRUCTION SHEET FOR PROPER SETUP AND ADJUSTMENTS.

PACIFIC VERSION
Shown on sheets 3 of 4 & 4 of 4
(Atlantic version shown on sheets 1 of 4 & 2 of 4)

LOC	DIST	REV	DATE	BY	APPV
A	66	-	-	-	-

REV	DATE	BY	APPV	DESCRIPTION	ITEM NO
-	1	1	2119082-5	CAM, SNAIL, INSULATION ADJUSTMENT	244
-	1	1	2079764-1	WASHER, WAVE SPRING, CREST-TO-CREST	243
-	1	1	2119083-1	RETAINER, INSULATION DIAL	242
-	1	1	7-18023-7	SCR, SKT HD CAP M3 X 4.0	241
-	-	1	2119580-1	MECHANICAL FEED ASSEMBLY	239
-	1	-	2844940-1	AIR FEED MODULE	238
-	REF	REF	994970-2	COUNTER, MAGNETIC	164
-	1	-	2119641-2	FEED CAM, AIR FEED	151
-	1	1	2168083-8	SCR, SKT HD CAP, RoHS, M4 X 16	144
-	4	4	2168083-9	SCR, SKT HD CAP, RoHS, M4 X 20	143
-	-	1	2119653-2	FEED CAM, POST FEED	142
-	1	1	1-1803583-0	APPLICATOR BASIC ASSEMBLY, SF	141
-	1	1	1803516-1	RAM ASSEMBLY, SF PACIFIC	140
-	1	1	2844908-1	SCREW, LOCKING	99
-	1	1	2844907-1	POST, LOCKING	98
-	1	1	455888-4	SPACER, CRIMPER	82
-	1	1	1803607-3	DOCUMENTATION PACKAGE	71
-	1	1	2119791-9	DEPRESSOR, WIRE	70
-	1	1	2119943-1	WASHER, SPACER	69
-	1	1	2119740-1	TAG, IDENTIFICATION	67
-	2	2	2168078-1	SCREW, DRIVE, RH, RoHS, 2 x .188	66
-	1	1	5-18022-5	SCR, HEX HD CAP, M4 X 6.0	59
-	1	1	1338685-1	PAWL, FEED	56
-	2	2	2-2168083-5	SCR, SKT HD CAP, RoHS, M4 X 14	53
-	1	1	1803382-6	HOLD DOWN, SPRING LOADED	50
-	1	2	18023-9	SCR, SKT HD CAP M4 X 6.0	49
-	-	1	2119652-1	FEED CAM, PRE FEED	48
-	1	1	1803602-1	SCR, BHSC, RoHS (M8 X 25)	41
-	1	1	1752356-1	SUPPORT, TERMINAL	34
-	2	2	2079383-5	SCR, BHSC, RoHS (M4 X 20)	33
-	2	2	2-2844962-4	SPACER, CYLINDRICAL, STRIP GUIDE	30
-	1	1	2844992-1	ASSEMBLY, STRIP GUIDE	29
-	1	1	455888-3	SPACER, CRIMPER	28
-	1	1	1320928-6	STRIP GUIDE	24
-	1	1	2168083-2	SCR, SKT HD CAP, RoHS, M4 X 8.0	21
-	2	2	1-18028-2	WASHER, FLAT, REG M4	20
-	1	1	2119533-1	STRIPPER, SIDE FEED	19
-	1	1	2119806-1	INSERT, SHEAR	13
-	1	1	3-22280-3	SPRING, COMPRESSION	12
-	1	1	1-356885-4	STOP, SHEAR	11
-	1	1	2119805-1	SHEAR HOLDER, FRONT	10
-	1	1	1803095-3	FLOATING SHEAR, FRONT	9
-	1	1	2-1633917-6	ANVIL, COMBINATION	8
-	1	1	240641-5	SPACER	7
-	-	-	-	-	6
-	1	1	2119757-1	DEPRESSOR, SHEAR	5
-	1	1	2-238011-2	BLOCK, CRIMPER SPACER	4
-	1	1	3-1633966-0	CRIMPER, INSULATION O	3
-	1	1	455888-3	SPACER, CRIMPER	2
-	1	1	1-456402-4	CRIMPER, WIRE PREMIUM	1

DIMENSIONS: mm		TOLERANCES UNLESS OTHERWISE SPECIFIED:		OWN: HOFFNER 13JUNE2014	CHK: T. ELBIN 16JUNE2014	APVD: T. ELBIN 16JUNE2014	NAME: Ocean Side Feed Applicator
0 PLC	±	1 PLC	±	SIZE: A1	CAGE CODE: 00779	DRAWING NO: C=2266335	RESTRICTED TO: -
2 PLC	±	3 PLC	±	WEIGHT: -	SCALE: 1:2	SHEET: 3 of 4	REV: E
4 PLC	±	ANGLES FINISH: -		Customer Accessible Production Drawing			

LOC		DIST		REVISIONS			
A	66	P	LYR	DESCRIPTION	DATE	OWN	APVD
		-		SEE SHEET 1	-	-	-

FEED TYPE MECHANICAL

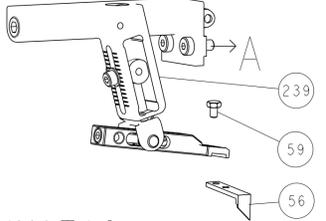

PNEUMATIC

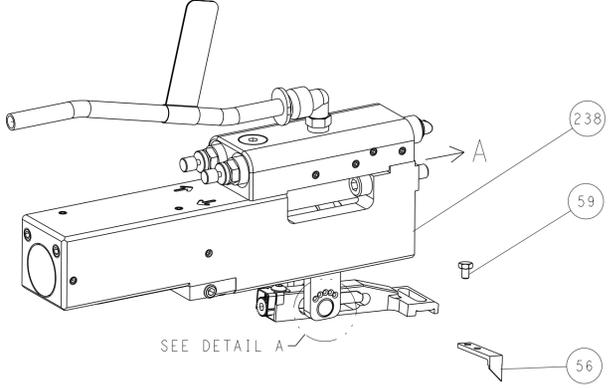

FEED SPRING SETTING POSITION (SHOWN FROM REAR SIDE)

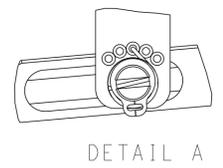

CAM POSITIONS

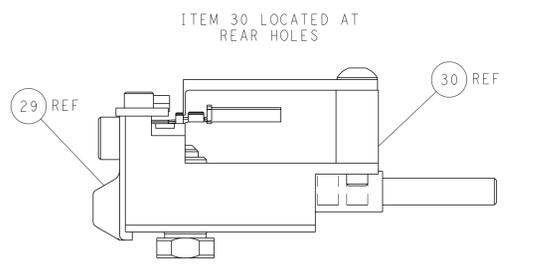
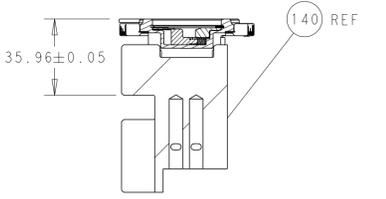
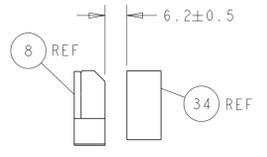
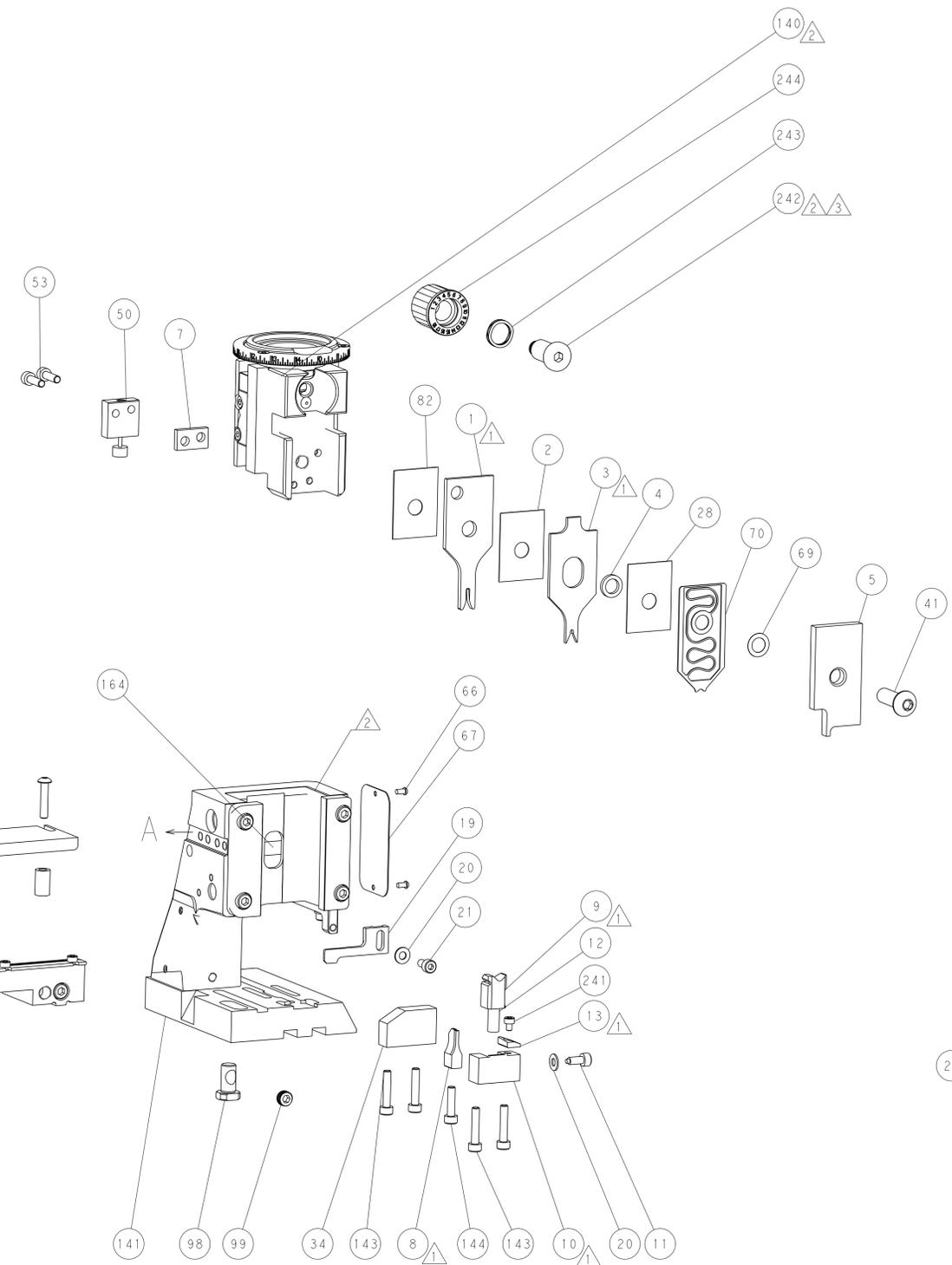
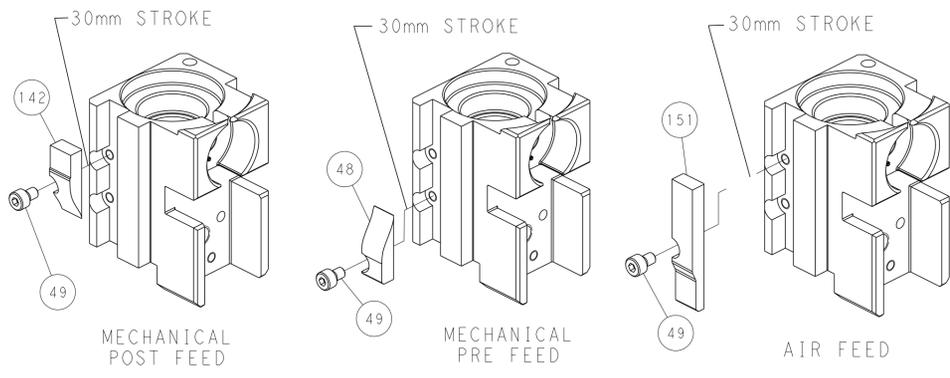

FEED TRACK POSITION GUIDE BY INSULATION BARREL

PACIFIC VERSION
 Shown on sheets 3 of 4 & 4 of 4
 (Atlantic version shown on sheets 1 of 4 & 2 of 4)

<small>THIS DRAWING IS A CONTROLLED DOCUMENT FOR TYCO ELECTRONICS CORPORATION. IT IS SUBJECT TO CHANGE AND THE CONTROLLER'S ENGINEERING DEPARTMENT SHOULD BE CONTACTED FOR THE LATEST REVISION.</small>		OWN: HOFFNER CHK: T. ELBIN APVD: T. ELBIN PRODUCT SPEC: - APPLICATION SPEC: - MATERIAL: - FINISH: -	DATE: 13JUNE2014 DATE: 16JUNE2014 DATE: 16JUNE2014 NAME: Ocean Side Feed Applicator SIZE: A1 CAGE CODE: 00779 DRAWING NO: C=2266335 SCALE: 1:2 SHEET: 4 of 4 REV: E	TE Connectivity Harrisburg, PA 17105-3608
---	--	---	--	--