

THIS DRAWING IS UNPUBLISHED. RELEASED FOR PUBLICATION
 © COPYRIGHT 2013 BY TYCO ELECTRONICS CORPORATION. ALL RIGHTS RESERVED.

LOC	DW	DIST	REVISIONS					
			P	LTR	DESCRIPTION	DATE	DWN	APVD
			B		ECR-13-008153	17MAY13	AW	WK

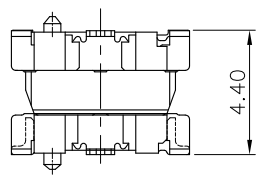
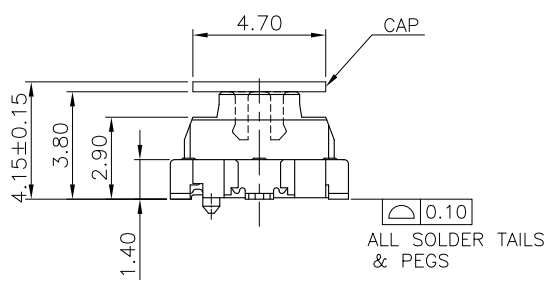
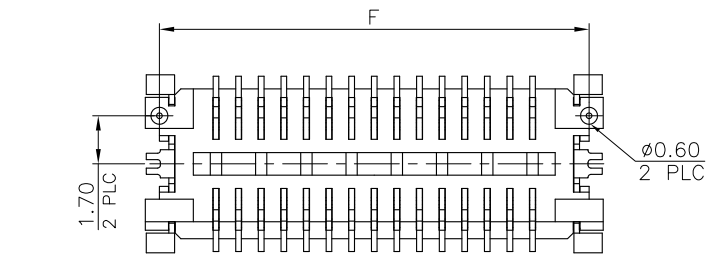
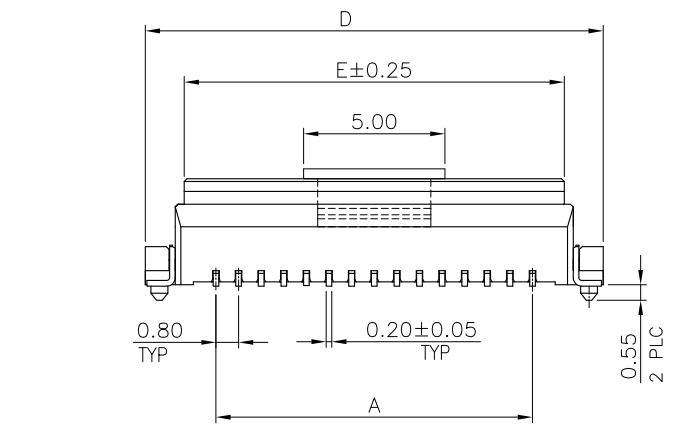
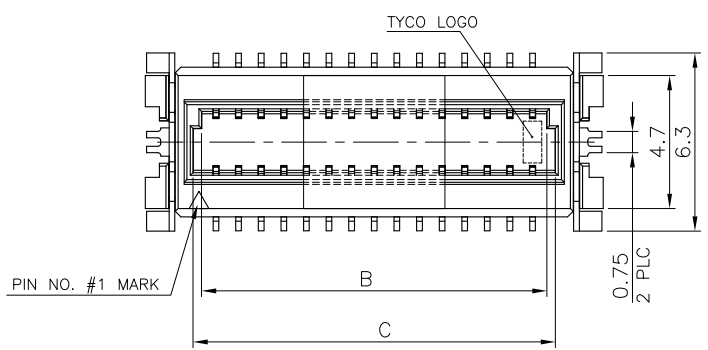

STACKING HEIGHT

- NOTES:
- MATERIAL:
HOUSING: PA6T WITH 30% GF, UL94 V-0, NATURAL COLOR.
CONTACTS: PHOSPHOR BRONZE.
PEGS: BRASS.
 - FINISH:
CONTACTS: 2.54µm [100µ"] MIN. MATTE-TIN OVER 1.27µm [50µ"] MIN. NICKEL ON ENTIRE CONTACT.
PEGS: 2.54µm [100µ"] MIN. MATTE-TIN OVER 1.27µm [50µ"] MIN. NICKEL.
 - REFLOW SOLDER CAPABLE TO 260°C AS PER TEC-109-201, CONDITION B.
 - SUBSTANCE RESTRICTIONS FOR LOW HALOGEN (BY WEIGHT):
BROMINE (Br) ≤ 900 PPM (0.09%)
CHLORINE (Cl) ≤ 900 PPM (0.09%)
TOTAL CONCENTRATION OF (Cl) + (Br) ≤ 1500 PPM (0.15%)

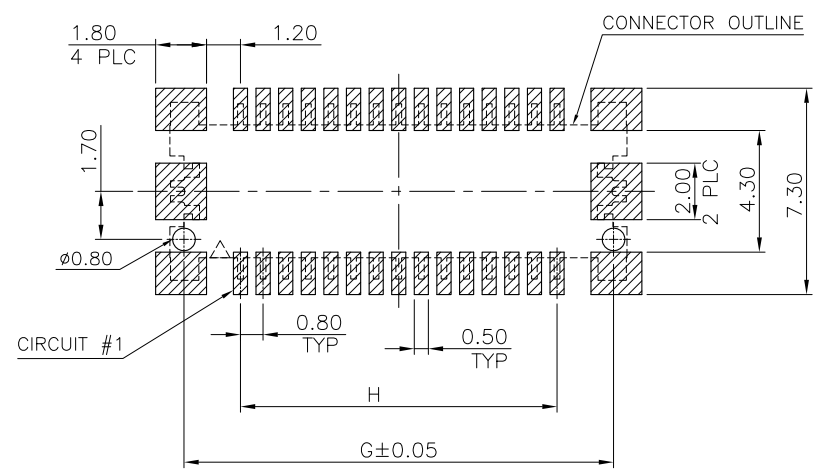

RECOMMENDED PCB LAYOUT

4.00	8	8.00	6.25	9.00	5.62	5.02	4.00	12	1-1775629-2
H	G	F	E	D	C	B	A	NO. OF CONTACTS	PART NUMBER
DIMENSIONS									

THIS DRAWING IS A CONTROLLED DOCUMENT.		DWN	A. WU	15MAY2007	 TE Connectivity	0.8 MM PITCH BOARD-TO-BOARD CONNECTOR, MATING HEIGHT 4.4 MM, SMT WITH CAP			
DIMENSIONS: MM		CHK	S. HOU	15MAY2007					
TOLERANCES UNLESS OTHERWISE SPECIFIED:		APVD	W.J. KE	15MAY2007					
0 PLC ± - 1 PLC ± 0.3 2 PLC ± 0.2 3 PLC ± - 4 PLC ± - ANGLES ± 3'		PRODUCT SPEC		NAME					
MATERIAL		SEE NOTE		FINISH		108-57488		QUALIFICATION TEST REPORT	
SEE NOTE		SEE NOTE		MATERIAL		501-57566		WEIGHT	
				0.22g GRAMS		A3 00779		DRAWING NO	
				CUSTOMER DRAWING		C=1775629		RESTRICTED TO	
				SCALE		SHEET		REV	
				-		1 OF 2		B	

THIS DRAWING IS UNPUBLISHED. RELEASED FOR PUBLICATION
 © COPYRIGHT 2013 BY TE CONNECTIVITY. ALL RIGHTS RESERVED.

LOC	DIST	REVISIONS					
DW	-	P	LTR	DESCRIPTION	DATE	DWN	APVD
				SEE SHEET 1			

- NOTES:
- MATERIAL:
 BOX: FIBREBOARD, CORRUGATED, DOUBLE WALL.
 COVER TAPE: PET, TRANSPARENT COLOR.
 CARRIER TAPE: POLYSTYRENES, TRANSPARENT COLOR.
 REEL: HIPS, BLUE COLOR.
 BAG: POLYETHYLENES, TRANSPARENT COLOR.
 - EACH BAG SHALL BE INCLUDED DESICCANT.
 - PEELING STRENGTH: 0.1 ~ 1.3 N (10 ~ 130 GRAMS).
 - PEELING SPEED: 300 mm/min.

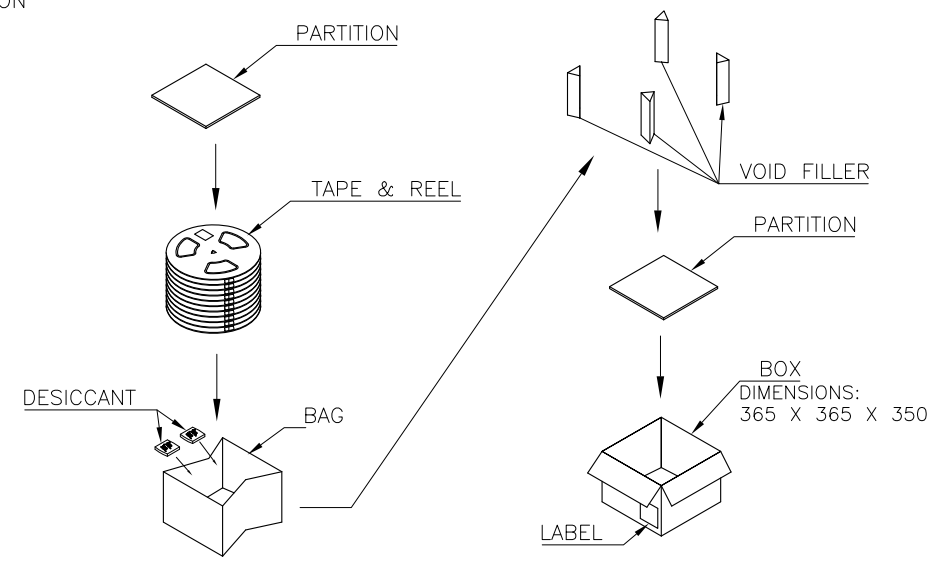
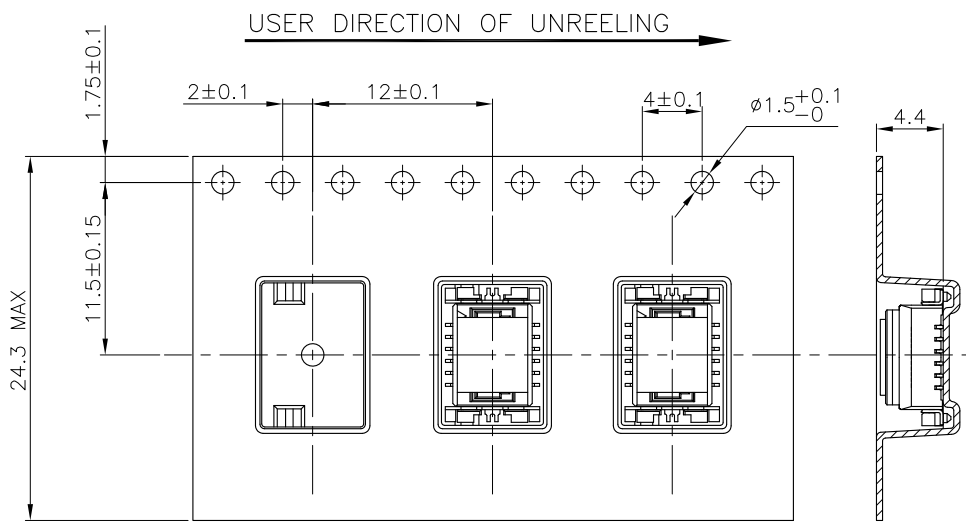
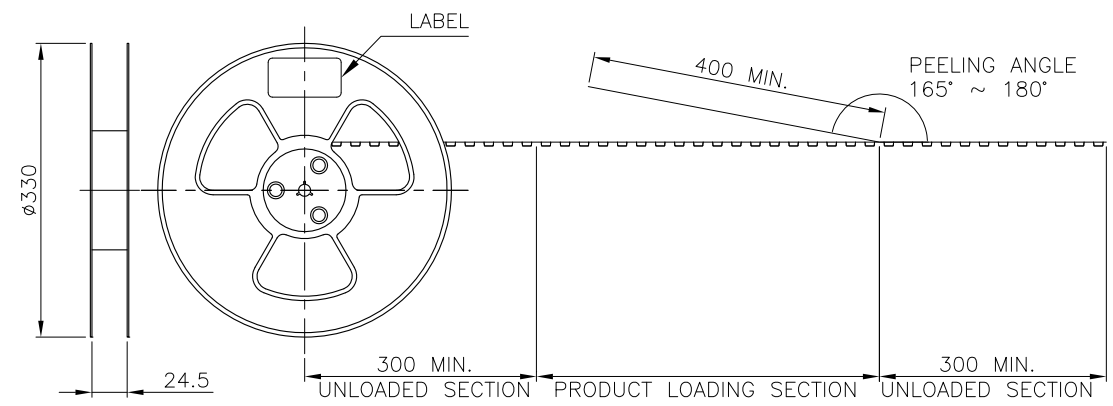

8000	800	10	8.21	2.16	12
PCS /BOX	PCS /REELS	REELS /BOX	GROSS WEIGHT (Kg)	NET WEIGHT (Kg)	NO. OF CONTACTS

THIS DRAWING IS A CONTROLLED DOCUMENT.		DWN	-	TE Connectivity 0.8 MM PITCH BOARD-TO-BOARD CONNECTOR, MATING HEIGHT 4.4 MM, SMT WITH CAP	
DIMENSIONS: MM		CHK	-		
TOLERANCES UNLESS OTHERWISE SPECIFIED:		APVD	-		
0 PLC ± - 1 PLC ± - 2 PLC ± - 3 PLC ± - 4 PLC ± - ANGLES ± -		PRODUCT SPEC	-		
MATERIAL		FINISH	-	APPLICATION SPEC	-
		WEIGHT	-	SIZE	A3
		CUSTOMER DRAWING		CAGE CODE	00779
				DRAWING NO	C=1775629
				RESTRICTED TO	-
				SCALE	-
				SHEET	2 of 2
				REV	B