

L99PM62GXP & L99PM72GXP Evaluation Board

Data brief



- ST SPI interface for mode control and diagnosis
- 5 fully protected high-side drivers with internal 4-channel PWM generator
- 2 low-side drivers with active Zener clamping
- 4 internal PWM timers
- 2 operational amplifiers with rail-to-rail outputs (VS) and low voltage inputs
- Temperature warning and thermal shutdown
- Graphic User Interface (GUI)

Features

Type	Transceiver	Outputs
L99PM62GXP	LIN:20 Kbit/s	5V@250mA
L99PM72GXP	HS CAN: 1 Mbit/s	5V@100mA

- Two 5V voltage regulators for microcontroller and peripheral supply
- Ultra low quiescent current in standby modes
- Programmable reset generator for power-on and undervoltage
- Configurable window watchdog and fail safe output
- LIN 2.1 compliant (SAEJ2602 compatible) transceiver
- Advanced HS CAN transceiver (ISO 11898-2/-5 and SAE J2284 compliant) with local failure and bus failure diagnosis, L99PM72GXP supports selective wake-up functionality as for ISO 11898-6.
- 3-channel contact monitoring interface with programmable cyclic sense functionality
- Programmable periodic system wake-up feature

Description

EVAL-L99PM62-72 is designed to evaluate the performance of two Power Management. The evaluation board comes pre-assembled with L99PM62GXP and L99PM72GXP ICs providing electronic control modules with enhanced power management functionality including various standby modes, as well as LIN and HS CAN physical communication layers. This Evaluation board consists of a motherboard (STM8 Universal Board) and two daughterboards. The motherboard, based on STM8 microcontroller, provides the logic section for monitoring and driving the devices assembled in two different daughterboards. With the aim to make the board usage and settings simpler, ST provides a dedicated user-friendly software with a Graphic User Interface (GUI). This enables the user to set L99PM62GXP and L99PM72GXP parameters and registers, simultaneously showing real time device diagnostic information like output current evolution, battery voltage monitoring, board temperature and much more.

Table 1. Device summary

Order code	Reference
EVAL-L99PM62-72	L99PM62GXP & L99PM72GXP Evaluation board

Contents

- 1 Application schematics and layouts 5**
 - 1.1 L99PM62GXP/L99PM72GXP daughterboard 5
 - 1.2 STM8 motherboard 8

- 2 Revision history 13**

List of tables

Table 1.	Device summary	1
Table 2.	Document revision history	13

List of figures

Figure 1.	L99PM62GXP/L99PM72GXP daughterboard top layer	5
Figure 2.	L99PM62GXP/L99PM72GXP daughterboard bottom layer	6
Figure 3.	L99PM62GXP/L99PM72GXP daughterboard application schematic	7
Figure 4.	STM8 motherboard top layer	8
Figure 5.	STM8 motherboard bottom layer	9
Figure 6.	STM8 motherboard – I/O & Body application schematic	10
Figure 7.	STM8 motherboard – STM8 & Supply application schematic	11
Figure 8.	STM8 motherboard USB interface application schematic	12

1 Application schematics and layouts

1.1 L99PM62GXP/L99PM72GXP daughterboard

Figure 1. L99PM62GXP/L99PM72GXP daughterboard top layer

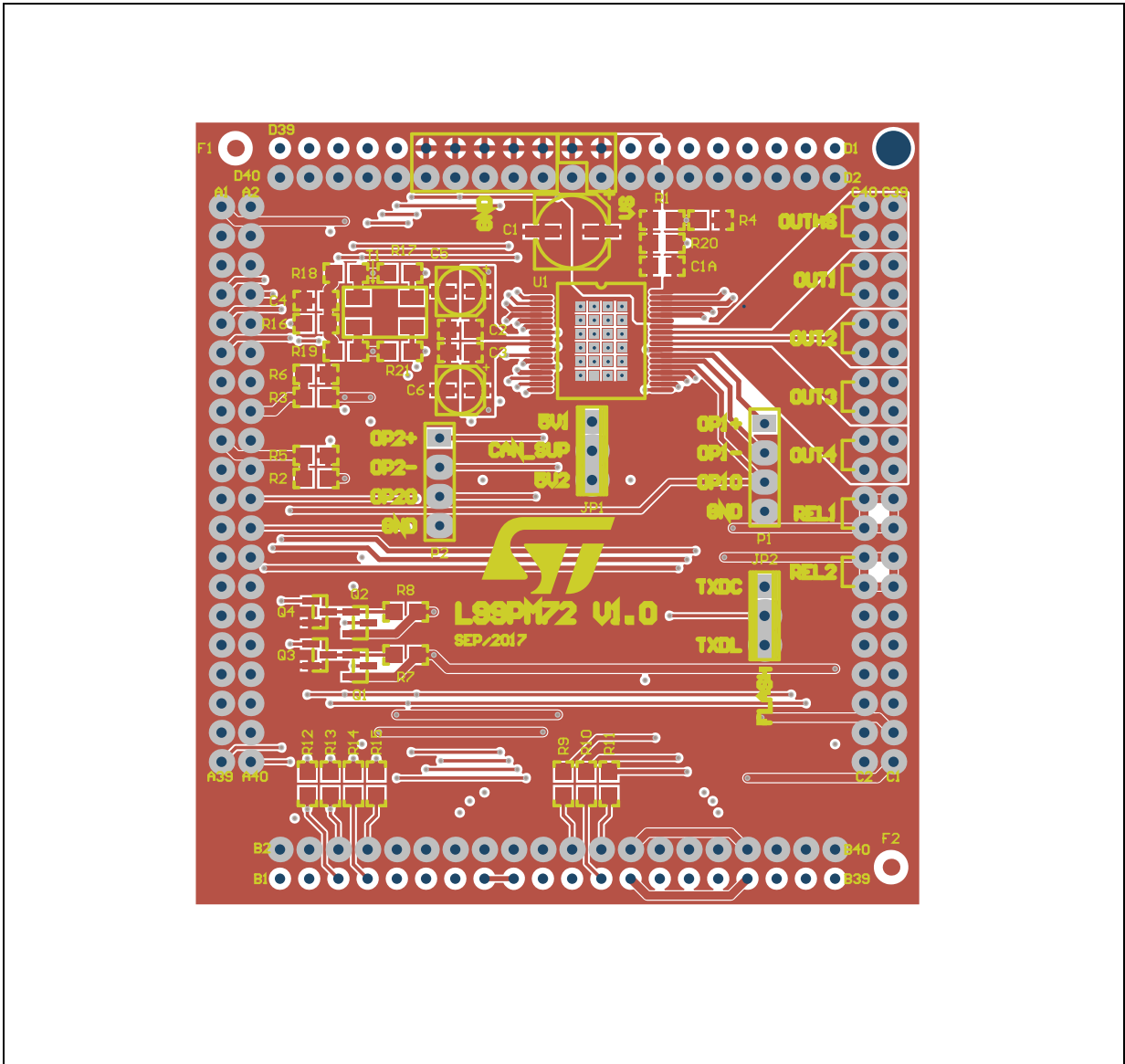

Figure 2. L99PM62GXP/L99PM72GXP daughterboard bottom layer

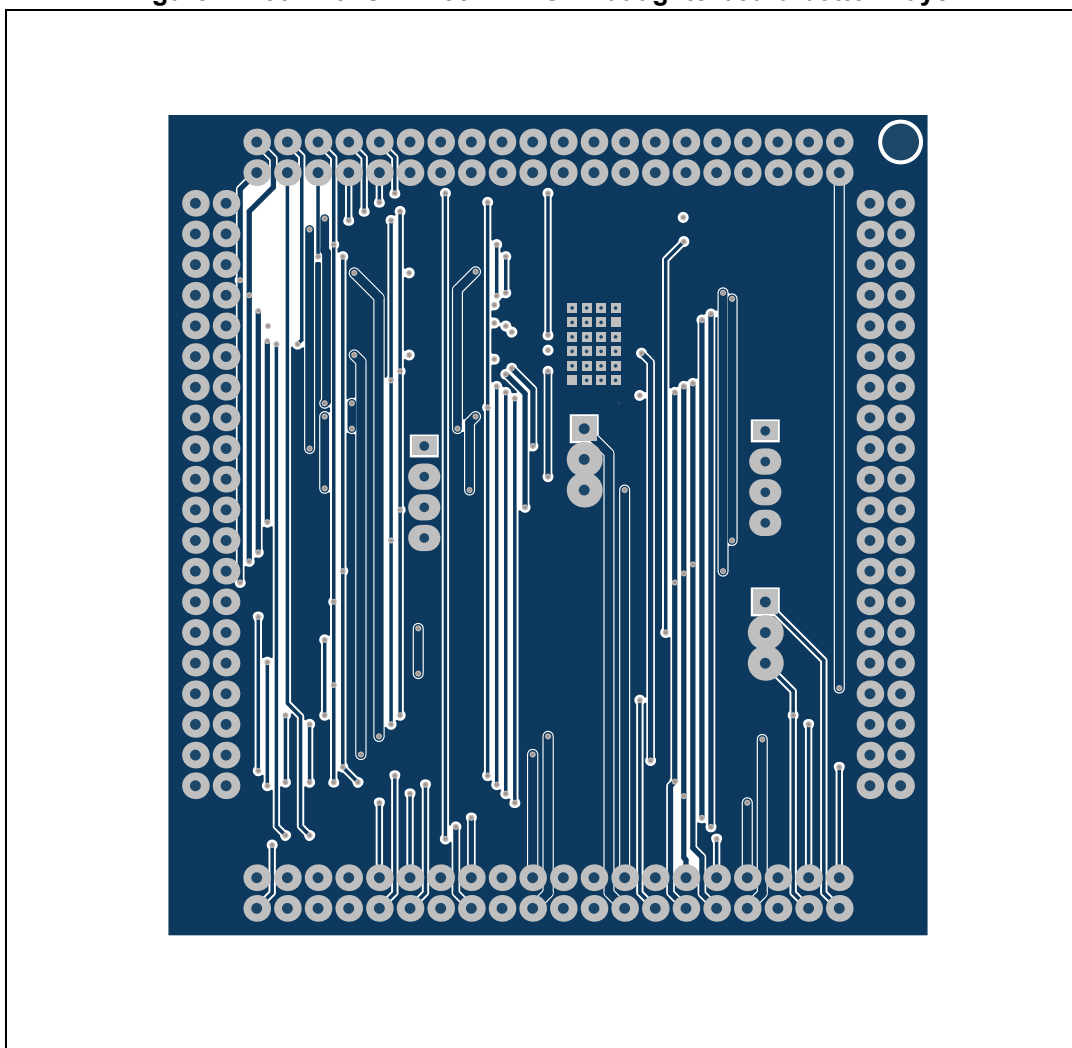
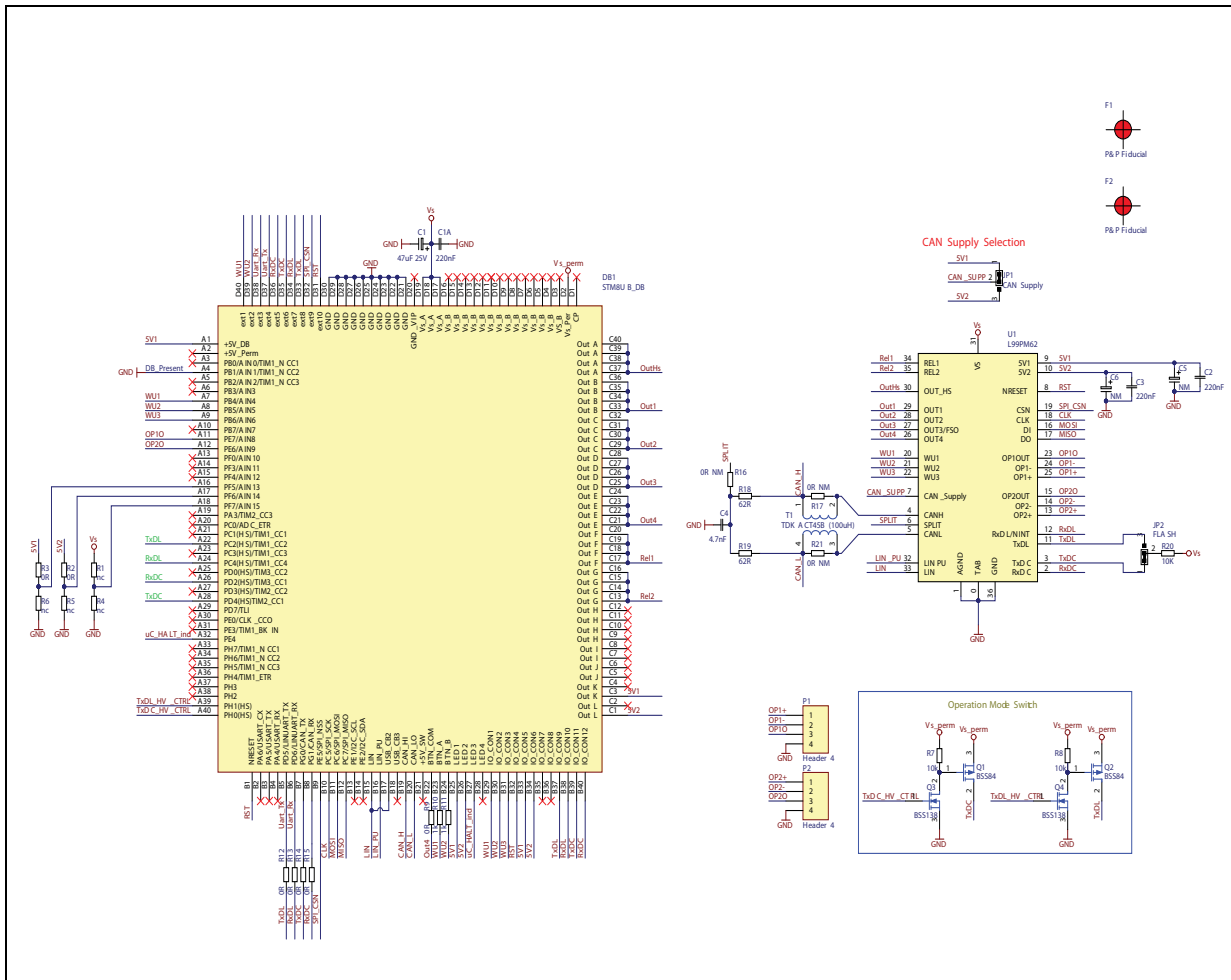

Figure 3. L99PM62GXP/L99PM72GXP daughterboard application schematic



1.2 STM8 motherboard

Figure 4. STM8 motherboard top layer

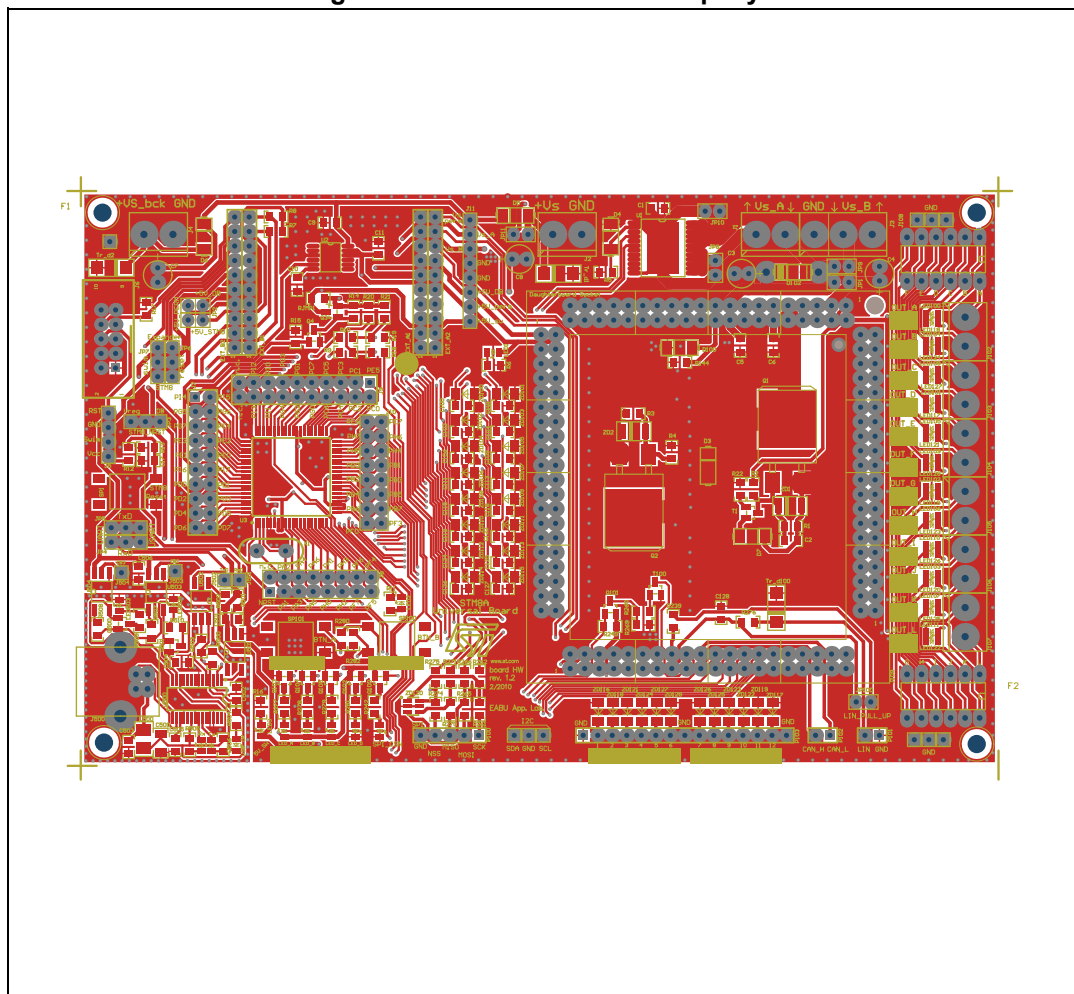

Figure 5. STM8 motherboard bottom layer

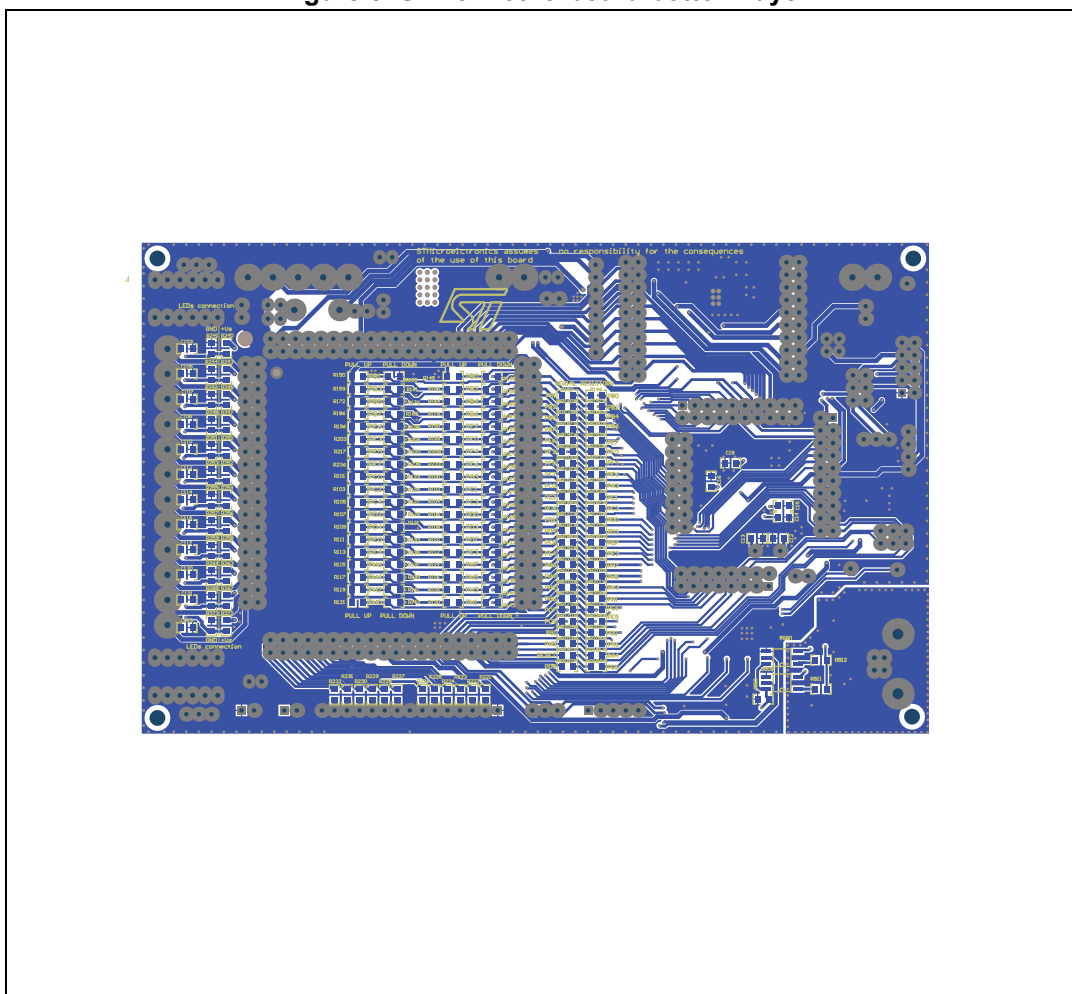

Figure 7. STM8 motherboard – STM8 & Supply application schematic

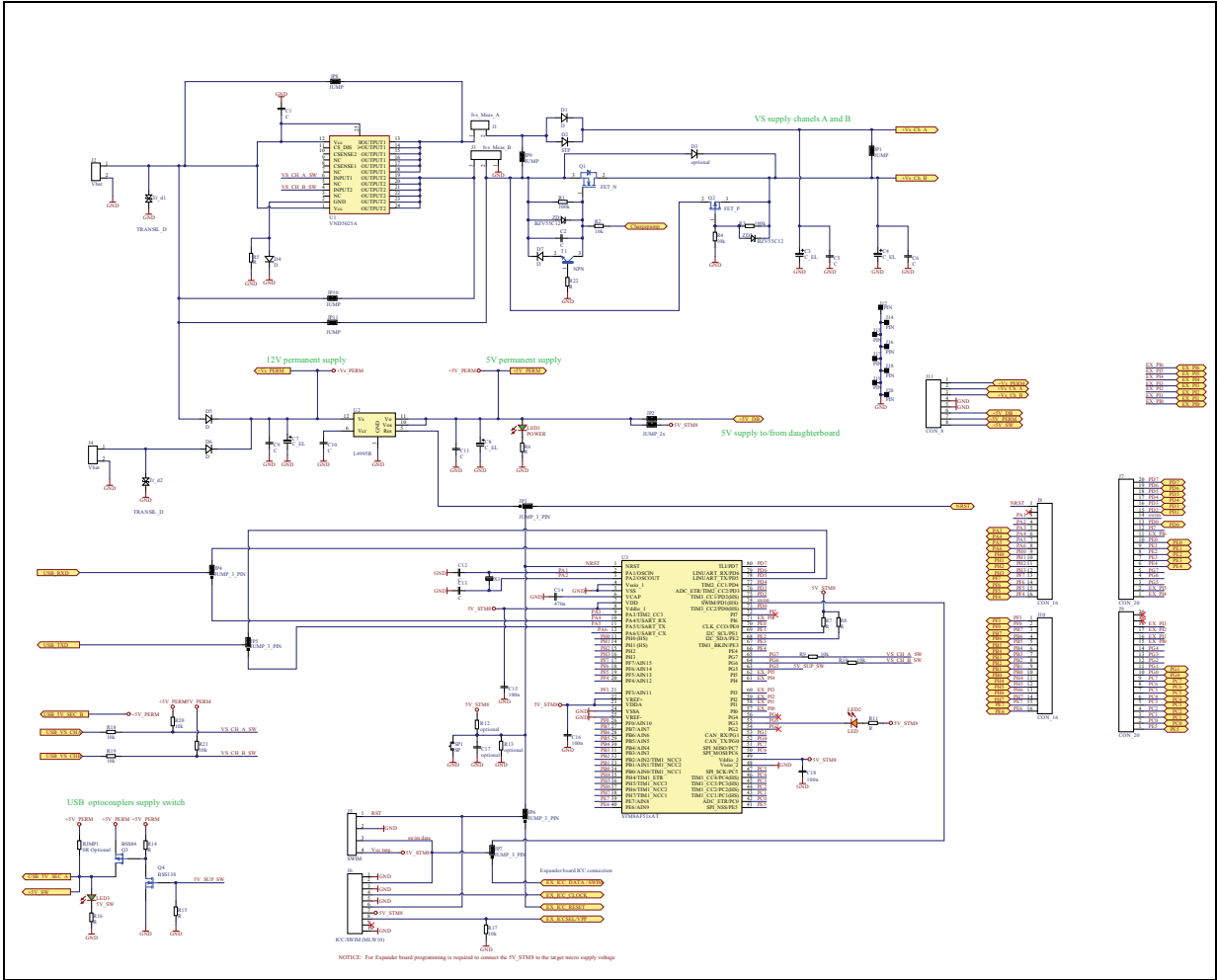
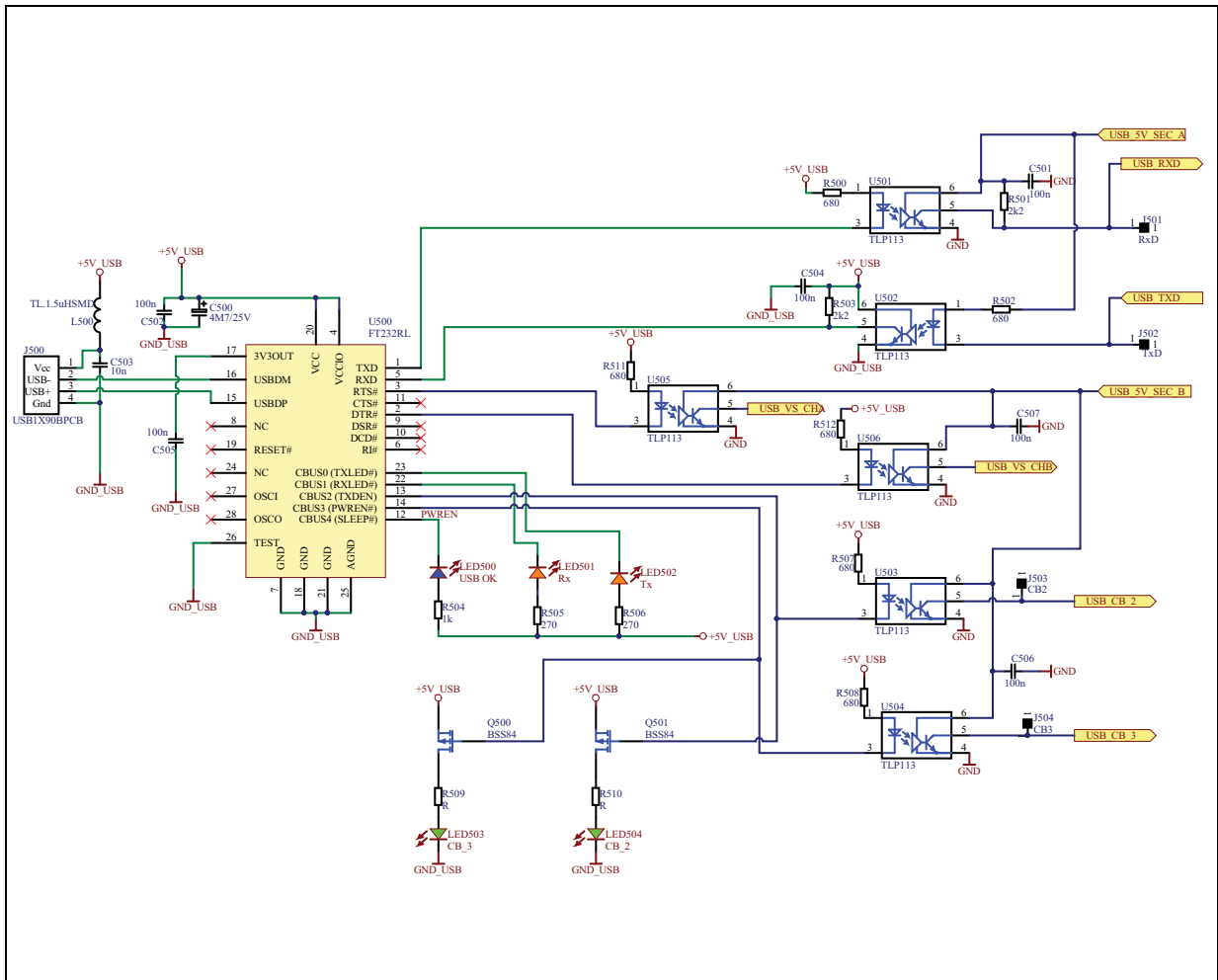

Figure 8. STM8 motherboard USB interface application schematic



2 Revision history

Table 2. Document revision history

Date	Revision	Changes
14-Mar-2018	1	Initial release.
18-Feb-2020	2	Typos.

IMPORTANT NOTICE – PLEASE READ CAREFULLY

STMicroelectronics NV and its subsidiaries (“ST”) reserve the right to make changes, corrections, enhancements, modifications, and improvements to ST products and/or to this document at any time without notice. Purchasers should obtain the latest relevant information on ST products before placing orders. ST products are sold pursuant to ST’s terms and conditions of sale in place at the time of order acknowledgement.

Purchasers are solely responsible for the choice, selection, and use of ST products and ST assumes no liability for application assistance or the design of Purchasers’ products.

No license, express or implied, to any intellectual property right is granted by ST herein.

Resale of ST products with provisions different from the information set forth herein shall void any warranty granted by ST for such product.

ST and the ST logo are trademarks of ST. For additional information about ST trademarks, please refer to www.st.com/trademarks. All other product or service names are the property of their respective owners.

Information in this document supersedes and replaces information previously supplied in any prior versions of this document.

© 2020 STMicroelectronics – All rights reserved