

REVISIONS				
P.	LTN	DESCRIPTION	DATE	APVD
C1		REVISED PER ECO-15-001489	31JAN2015	AP DD

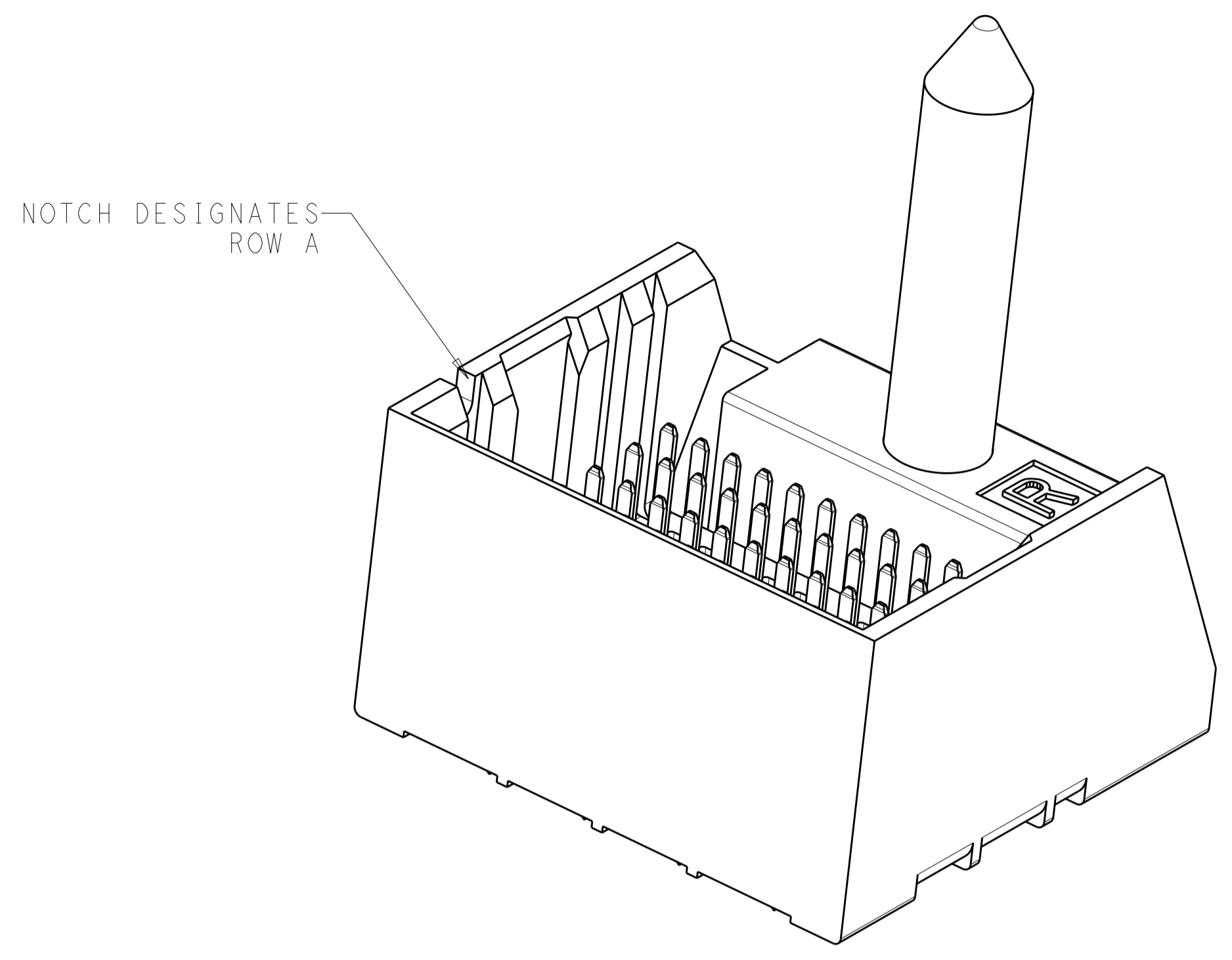

- 1 MATERIAL:
HOUSING: LCP, GLASS FILLED, UL94V-0.
TERMINALS: HIGH PERFORMANCE COPPER ALLOY.
- 2 FINISH:
30µ" MIN GOLD IN CONTACT AREA. SELECTIVE TIN ON PCB TAILS, NICKEL OVERALL.
- 3. SCREWS PACKAGED IN END OF PACKAGING TUBE.
- 4 FOR GROUNDED GUIDE PIN USE $\varnothing 3.56 \pm 0.08$ PTH, $\varnothing 3.66$ DRILL, AND $\varnothing 6.5$ PAD.

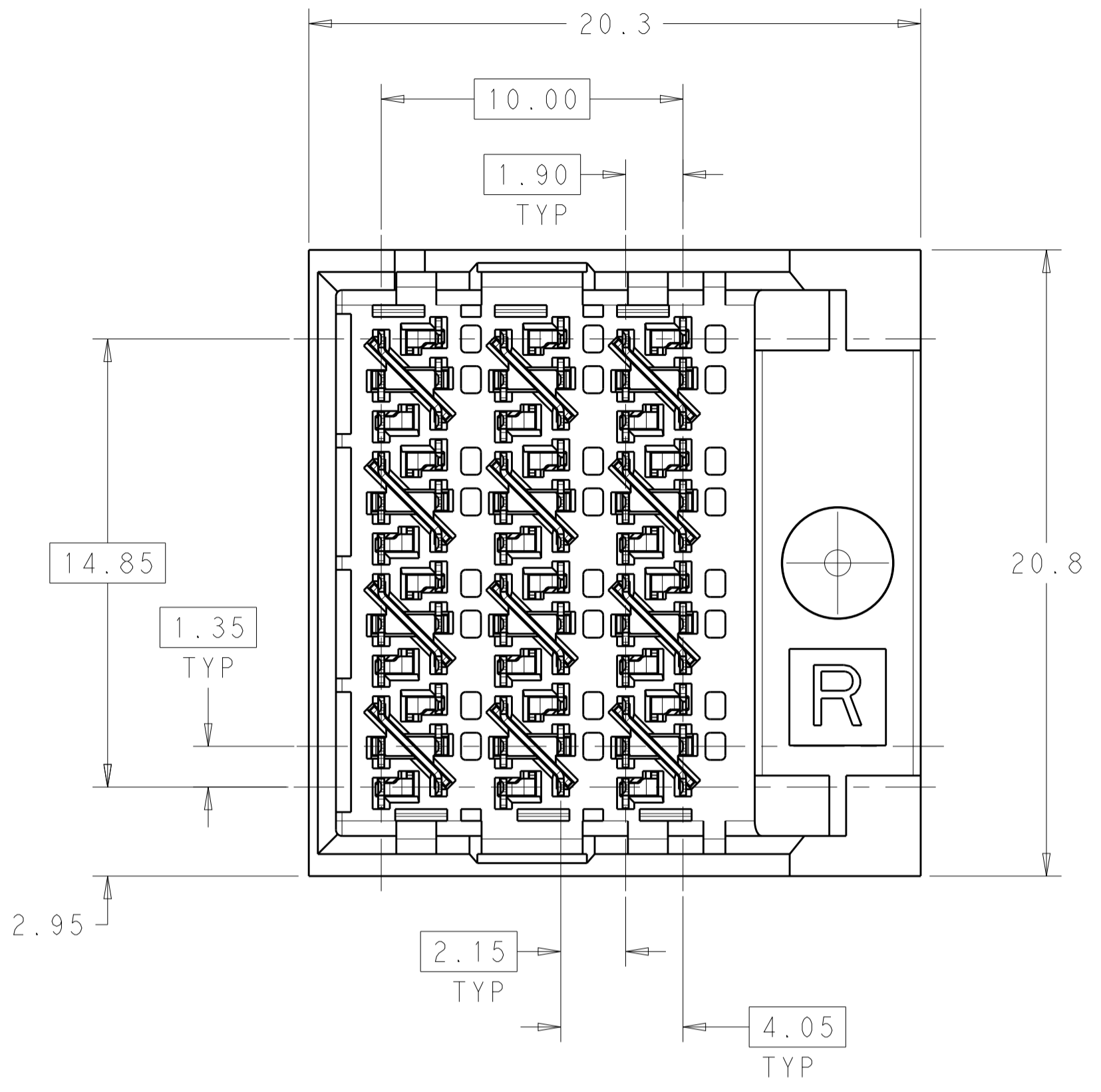
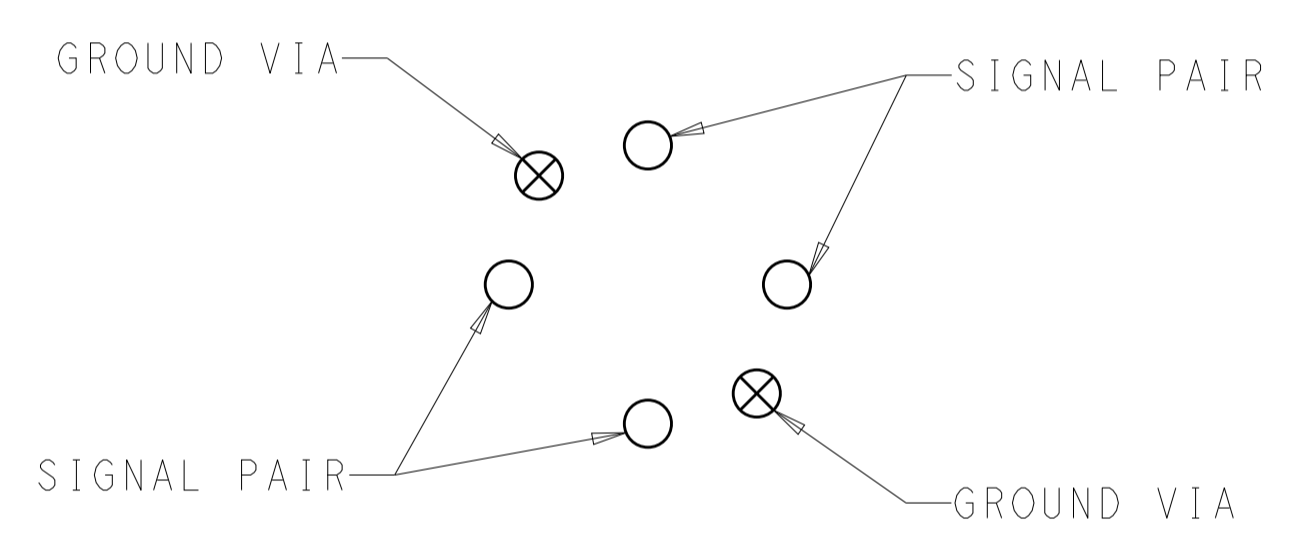

DETAIL X
SCALE 16:1

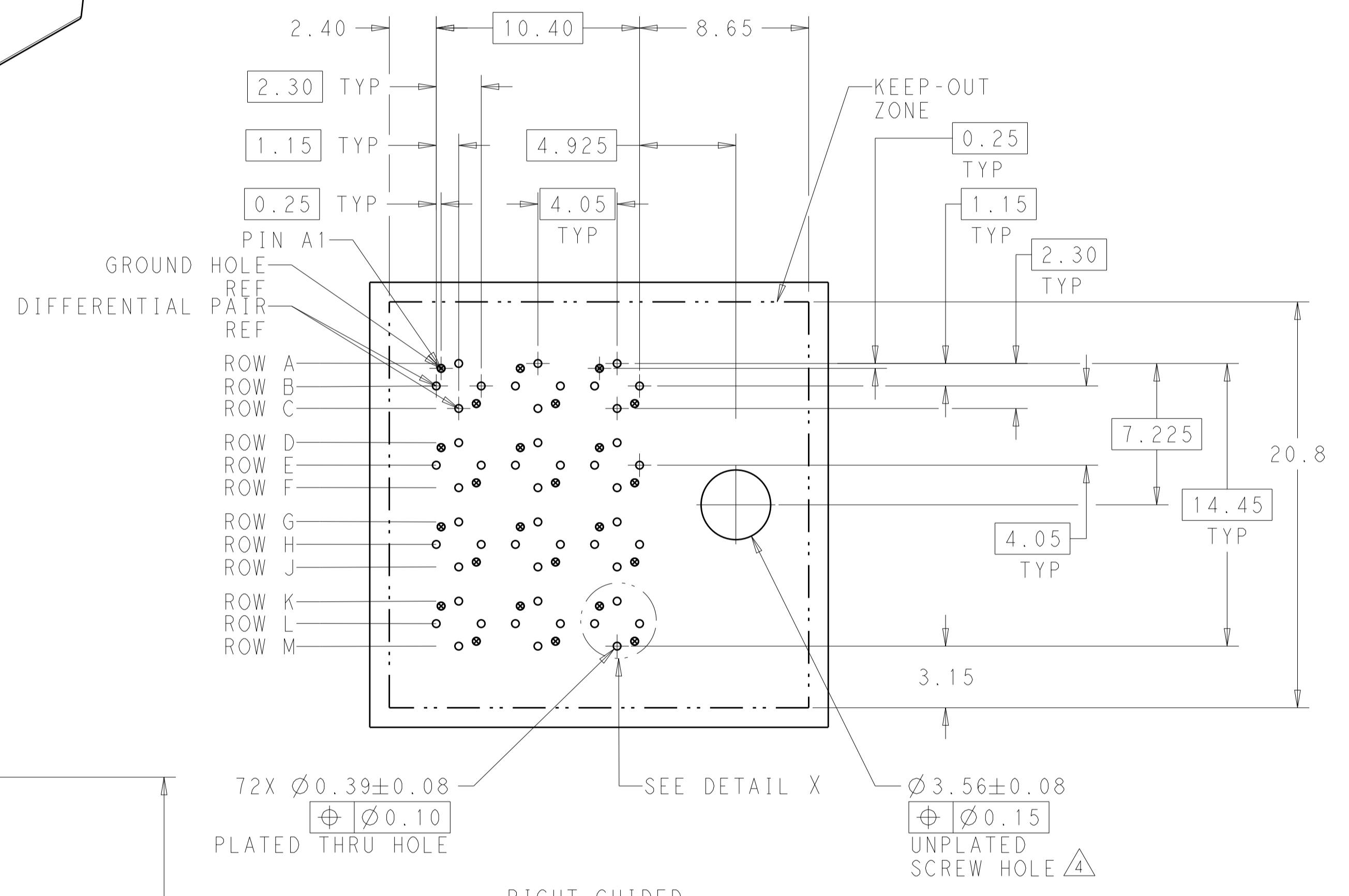

RIGHT GUIDED
BACKPLANE HOLE PATTERN
(CONNECTOR SIDE)

REFER TO WWW.TE.COM
FOR PRODUCT AVAILABILITY

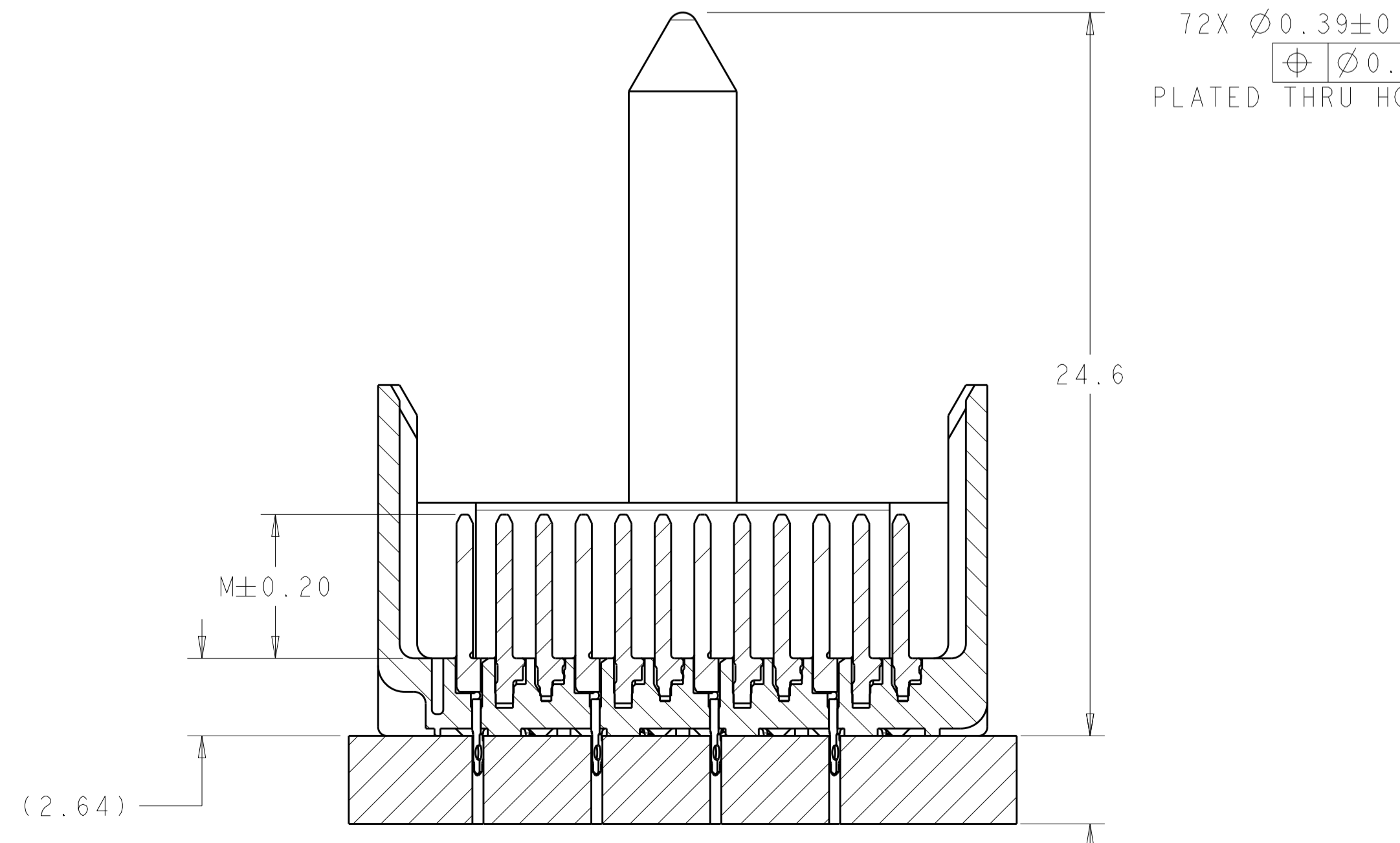
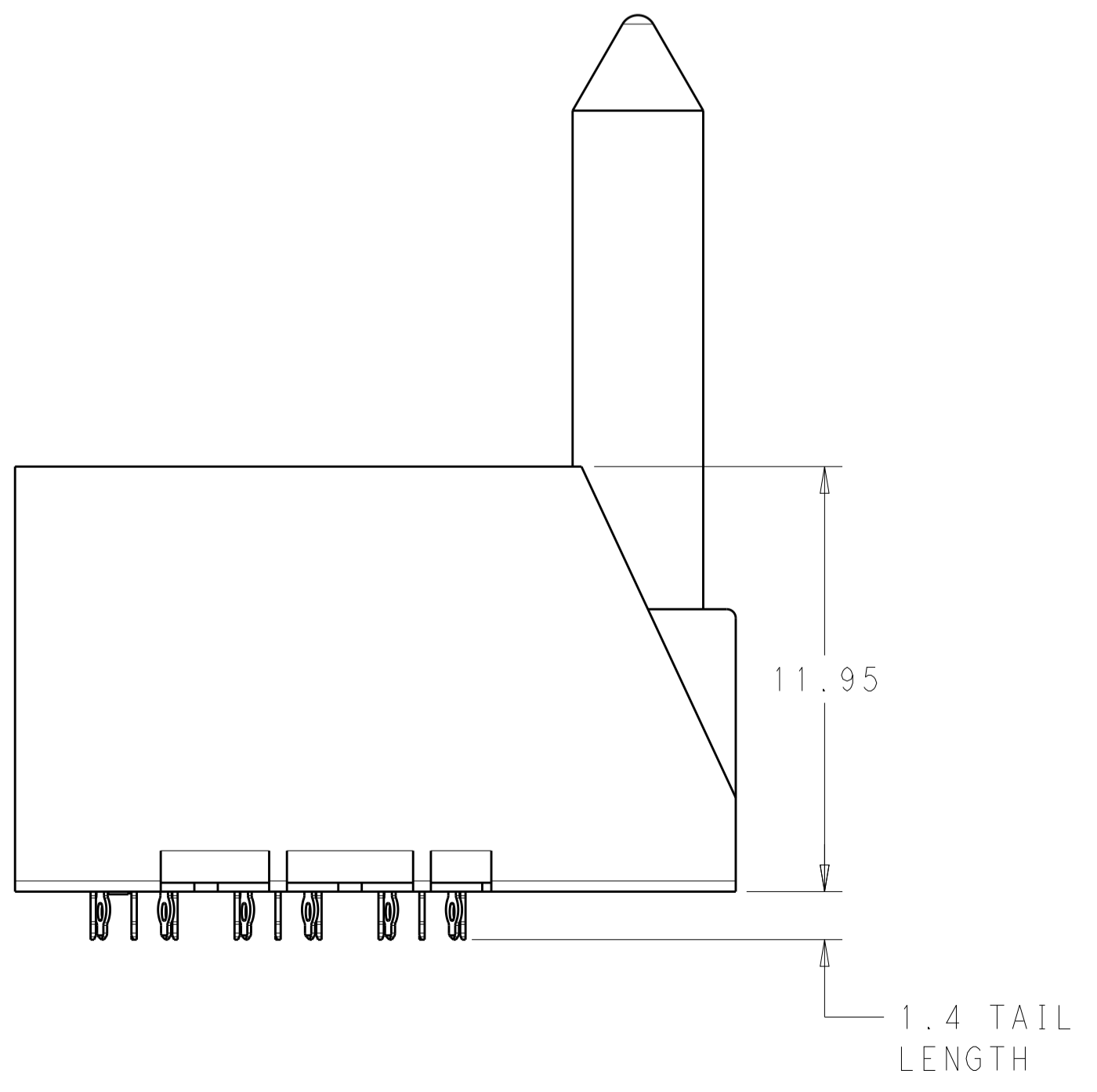

SECTION X-X

2	5.5	2132596-2
2	4.9	2132596-1
FINISH	DIM M	PART NUMBER

THIS DRAWING IS A CONTROLLED DOCUMENT.		OWN: R. IRAN HOLA 18OCT2012	CHK: D. DIXON 18OCT2012	APVD: D. DIXON 18OCT2012	NAME: IMPACT, ORTHOGONAL, 4 PAIR, 6 COLUMN HEADER, RIGHT GUIDED, LEFT END WALL SIGNAL MODULE, 0.39 PTH
DIMENSIONS:	TOLERANCES UNLESS OTHERWISE SPECIFIED:	PRODUCT SPEC	APPLICATION SPEC	SIZE	RESTRICTED TO
mm	0 PLC ±0.25 1 PLC ±0.13 2 PLC ±0.13 3 PLC ±0.13 4 PLC ±0.13			A100779	
MATERIAL:	FINISH:	WEIGHT:	CAGE CODE:	DRAWING NO:	SCALE: 6:1
	SEE TABLE			2132596	SHEET 1 OF 1
CUSTOMER DRAWING		SCALE: 6:1		SHEET 1 OF 1	