

SN64BCT244 OCTAL BUFFER/DRIVER WITH 3-STATE OUTPUTS

SCBS027A – FEBRUARY 1989 – REVISED JANUARY 1994

- State-of-the-Art BiCMOS Design Significantly Reduces I_{CCZ}
- 3-State Outputs Drive Bus Lines or Buffer-Memory Address Registers
- P-N-P Inputs Reduce DC Loading
- High-Impedance State During Power Up and Power Down
- Package Options Include Plastic Small-Outline (DW) Packages and Standard Plastic 300-mil DIPs (N)

DW OR N PACKAGE
(TOP VIEW)

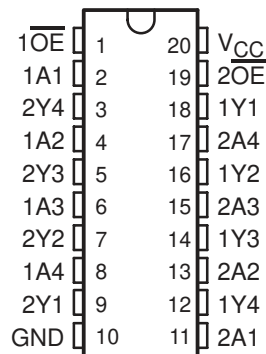

description

This octal buffer and line driver is designed specifically to improve both the performance and density of 3-state memory address drivers, clock drivers, and bus-oriented receivers and transmitters. Taken together with the SN64BCT240 and SN64BCT241, these devices provide the choice of selected combinations of inverting and noninverting outputs, symmetrical active-low output-enable (\overline{OE}) inputs, and complementary OE and \overline{OE} inputs.

The SN64BCT244 is organized as two 4-bit buffers/line drivers with separate output-enable (\overline{OE}) inputs. When \overline{OE} is low, the device passes data from the A inputs to the Y outputs. When \overline{OE} is high, the outputs are in the high-impedance state.

The outputs are in a high-impedance state during power up and power down while the supply voltage is less than approximately 3 V.

The SN64BCT244 is characterized for operation from -40°C to 85°C .

FUNCTION TABLE
(each buffer)

INPUTS		OUTPUT
\overline{OE}	A	Y
L	H	H
L	L	L
H	X	Z

SN64BCT244

OCTAL BUFFER/DRIVER WITH 3-STATE OUTPUTS

SCBS027A – FEBRUARY 1989 – REVISED JANUARY 1994

logic symbol†

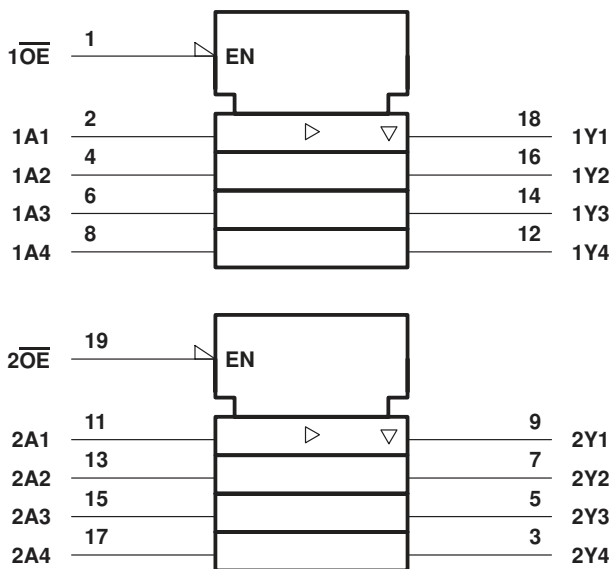

† This symbol is in accordance with ANSI/IEEE Std 91-1984 and IEC Publication 617-12.

logic diagram (positive logic)

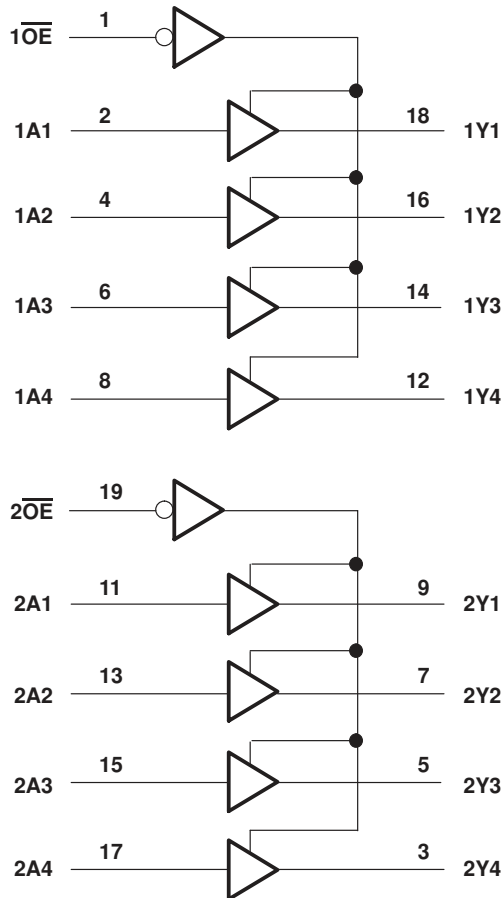

absolute maximum ratings over operating free-air temperature range (unless otherwise noted)‡

Supply voltage range, V_{CC}	-0.5 V to 7 V
Input voltage range, V_I (see Note 1)	-0.5 V to 7 V
Voltage range applied to any output in the disabled or power-off state, V_O	-0.5 V to 5.5 V
Voltage range applied to any output in the high state, V_O	-0.5 V to V_{CC}
Current into any output in the low state, I_O	128 mA
Operating free-air temperature range	-40°C to 85°C
Storage temperature range	-65°C to 150°C

‡ Stresses beyond those listed under "absolute maximum ratings" may cause permanent damage to the device. These are stress ratings only, and functional operation of the device at these or any other conditions beyond those indicated under "recommended operating conditions" is not implied. Exposure to absolute-maximum-rated conditions for extended periods may affect device reliability.

NOTE 1: The input negative voltage rating may be exceeded if the input clamp current rating is observed.



SN64BCT244 OCTAL BUFFER/DRIVER WITH 3-STATE OUTPUTS

SCBS027A – FEBRUARY 1989 – REVISED JANUARY 1994

recommended operating conditions

		MIN	NOM	MAX	UNIT
V_{CC}	Supply voltage	4.5	5	5.5	V
V_{IH}	High-level input voltage	2			V
V_{IL}	Low-level input voltage			0.8	V
I_{IK}	Input clamp current			-18	mA
I_{OH}	High-level output current			-15	mA
I_{OL}	Low-level output current			64	mA
T_A	Operating free-air temperature	-40		85	°C

electrical characteristics over recommended operating free-air temperature range (unless otherwise noted)

PARAMETER	TEST CONDITIONS		MIN	TYP†	MAX	UNIT
V_{IK}	$V_{CC} = 4.5$ V,	$I_I = -18$ mA			-1.2	V
V_{OH}	$V_{CC} = 4.5$ V	$I_{OH} = -3$ mA	2.4	3.3		V
		$I_{OH} = -15$ mA	2	3.1		
V_{OL}	$V_{CC} = 4.5$ V,	$I_{OL} = 64$ mA		0.42	0.55	V
I_I	$V_{CC} = 5.5$ V,	$V_I = 7$ V			0.1	mA
I_{IH}	$V_{CC} = 5.5$ V,	$V_I = 2.7$ V			20	μA
I_{IL}	$V_{CC} = 5.5$ V,	$V_I = 0.5$ V			-1	mA
I_{OZ}	$V_{CC} = 0$ to 2.3 V (power up)	$V_O = 2.7$ V or 0.5 V, \overline{OE} at 0.8 V			± 50	μA
	$V_{CC} = 1.8$ V to 0 (power down)				± 50	
I_{OZH}	$V_{CC} = 5.5$ V,	$V_O = 2.7$ V			50	μA
I_{OZL}	$V_{CC} = 5.5$ V,	$V_O = 0.5$ V			-50	μA
I_{OS}^\dagger	$V_{CC} = 5.5$ V,	$V_O = 0$	-100		-225	mA
I_{CCH}	$V_{CC} = 5.5$ V,	Output open		23	40	mA
I_{CCL}	$V_{CC} = 5.5$ V,	Output open		53	80	mA
I_{CCZ}	$V_{CC} = 5.5$ V,	Output open		4	10	mA

† All typical values are at $V_{CC} = 5$ V.

‡ Not more than one output should be tested at a time, and the duration of the test should not exceed one second.

switching characteristics (see Note 2)

PARAMETER	FROM (INPUT)	TO (OUTPUT)	$V_{CC} = 5$ V, $C_L = 50$ pF, $R_1 = 500$ Ω, $R_2 = 500$ Ω, $T_A = 25^\circ$ C			$V_{CC} = 4.5$ V to 5.5 V, $C_L = 50$ pF, $R_1 = 500$ Ω, $R_2 = 500$ Ω, $T_A = \text{MIN to MAX}^\S$		UNIT
			MIN	TYP	MAX	MIN	MAX	
t_{PLH}	A	Y	1.2	2.5	4.4	0.9	5.3	ns
t_{PHL}			1.7	3.2	5	1.4	6	
t_{PZH}	\overline{OE}	Y	2	5.7	7.8	2	9	ns
t_{PZL}			2	5.9	8.1	2	9.4	
t_{PHZ}	\overline{OE}	Y	2	5.4	6.7	2	8	ns
t_{PLZ}			2	6.1	7.6	2	9.8	

§ For conditions shown as MIN or MAX, use the appropriate value specified under recommended operating conditions.

NOTE 2: Load circuits and voltage waveforms are shown in Section 1.



PACKAGING INFORMATION

Orderable Device	Status (1)	Package Type	Package Drawing	Pins	Package Qty	Eco Plan (2)	Lead/Ball Finish (6)	MSL Peak Temp (3)	Op Temp (°C)	Device Marking (4/5)	Samples
SN64BCT244DW	ACTIVE	SOIC	DW	20	25	Green (RoHS & no Sb/Br)	NIPDAU	Level-1-260C-UNLIM	-40 to 85	6BCT244	Samples
SN64BCT244NSR	ACTIVE	SO	NS	20	2000	Green (RoHS & no Sb/Br)	NIPDAU	Level-1-260C-UNLIM	-40 to 85	DCT244	Samples

(1) The marketing status values are defined as follows:

ACTIVE: Product device recommended for new designs.

LIFEBUY: TI has announced that the device will be discontinued, and a lifetime-buy period is in effect.

NRND: Not recommended for new designs. Device is in production to support existing customers, but TI does not recommend using this part in a new design.

PREVIEW: Device has been announced but is not in production. Samples may or may not be available.

OBSELETE: TI has discontinued the production of the device.

(2) **RoHS:** TI defines "RoHS" to mean semiconductor products that are compliant with the current EU RoHS requirements for all 10 RoHS substances, including the requirement that RoHS substance do not exceed 0.1% by weight in homogeneous materials. Where designed to be soldered at high temperatures, "RoHS" products are suitable for use in specified lead-free processes. TI may reference these types of products as "Pb-Free".

RoHS Exempt: TI defines "RoHS Exempt" to mean products that contain lead but are compliant with EU RoHS pursuant to a specific EU RoHS exemption.

Green: TI defines "Green" to mean the content of Chlorine (Cl) and Bromine (Br) based flame retardants meet JS709B low halogen requirements of <=1000ppm threshold. Antimony trioxide based flame retardants must also meet the <=1000ppm threshold requirement.

(3) MSL, Peak Temp. - The Moisture Sensitivity Level rating according to the JEDEC industry standard classifications, and peak solder temperature.

(4) There may be additional marking, which relates to the logo, the lot trace code information, or the environmental category on the device.

(5) Multiple Device Markings will be inside parentheses. Only one Device Marking contained in parentheses and separated by a "~" will appear on a device. If a line is indented then it is a continuation of the previous line and the two combined represent the entire Device Marking for that device.

(6) Lead/Ball Finish - Orderable Devices may have multiple material finish options. Finish options are separated by a vertical ruled line. Lead/Ball Finish values may wrap to two lines if the finish value exceeds the maximum column width.

Important Information and Disclaimer:The information provided on this page represents TI's knowledge and belief as of the date that it is provided. TI bases its knowledge and belief on information provided by third parties, and makes no representation or warranty as to the accuracy of such information. Efforts are underway to better integrate information from third parties. TI has taken and continues to take reasonable steps to provide representative and accurate information but may not have conducted destructive testing or chemical analysis on incoming materials and chemicals. TI and TI suppliers consider certain information to be proprietary, and thus CAS numbers and other limited information may not be available for release.

In no event shall TI's liability arising out of such information exceed the total purchase price of the TI part(s) at issue in this document sold by TI to Customer on an annual basis.

TAPE AND REEL INFORMATION



QUADRANT ASSIGNMENTS FOR PIN 1 ORIENTATION IN TAPE



*All dimensions are nominal

Device	Package Type	Package Drawing	Pins	SPQ	Reel Diameter (mm)	Reel Width W1 (mm)	A0 (mm)	B0 (mm)	K0 (mm)	P1 (mm)	W (mm)	Pin1 Quadrant
SN64BCT244NSR	SO	NS	20	2000	330.0	24.4	8.4	13.0	2.5	12.0	24.0	Q1

TAPE AND REEL BOX DIMENSIONS



*All dimensions are nominal

Device	Package Type	Package Drawing	Pins	SPQ	Length (mm)	Width (mm)	Height (mm)
SN64BCT244NSR	SO	NS	20	2000	367.0	367.0	45.0

MECHANICAL DATA

NS (R-PDSO-G**)

PLASTIC SMALL-OUTLINE PACKAGE

14-PINS SHOWN



- NOTES:
- A. All linear dimensions are in millimeters.
 - B. This drawing is subject to change without notice.
 - C. Body dimensions do not include mold flash or protrusion, not to exceed 0,15.

DW0020A



PACKAGE OUTLINE

SOIC - 2.65 mm max height

SOIC

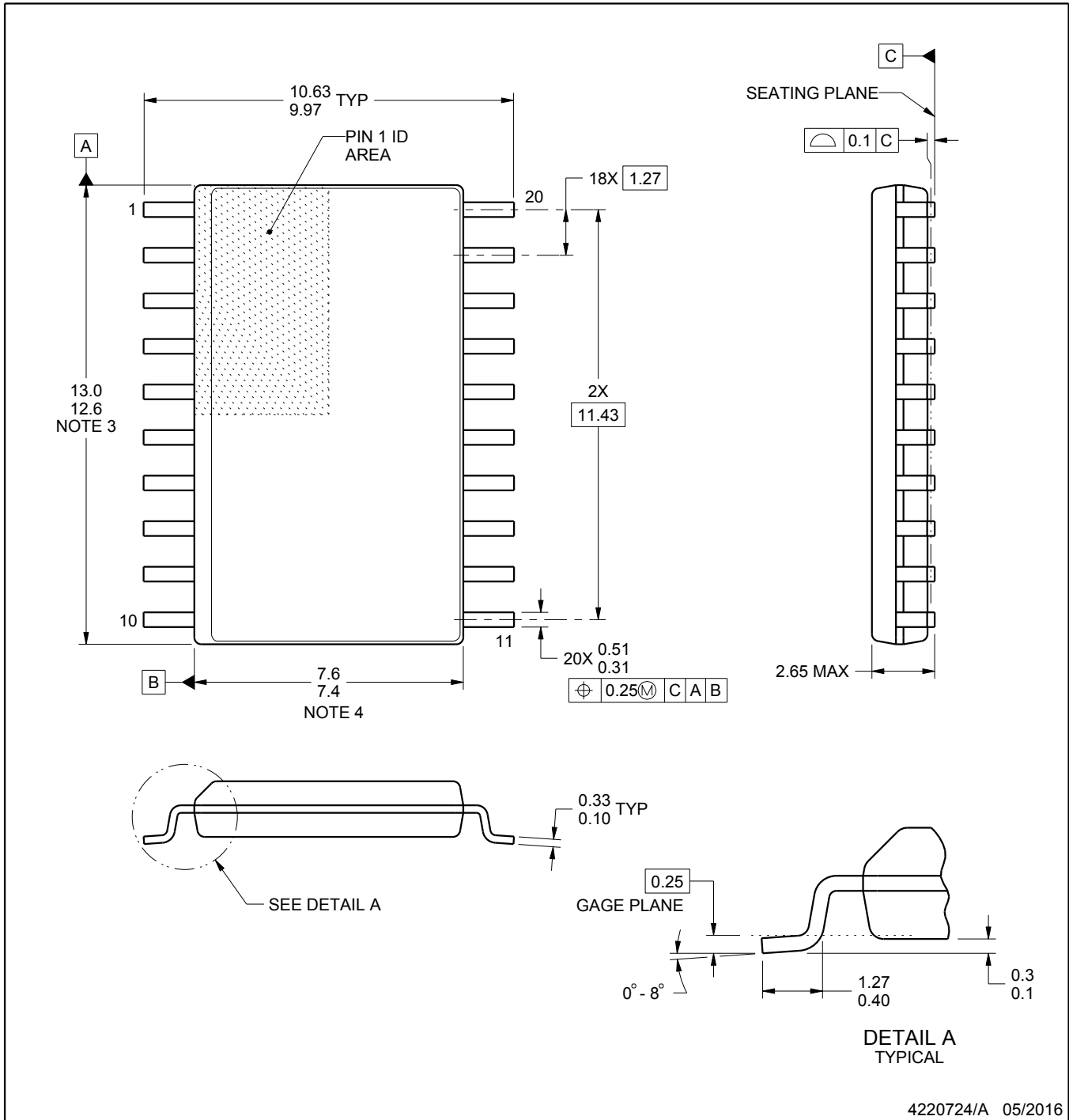

NOTES:

1. All linear dimensions are in millimeters. Dimensions in parenthesis are for reference only. Dimensioning and tolerancing per ASME Y14.5M.
2. This drawing is subject to change without notice.
3. This dimension does not include mold flash, protrusions, or gate burrs. Mold flash, protrusions, or gate burrs shall not exceed 0.15 mm per side.
4. This dimension does not include interlead flash. Interlead flash shall not exceed 0.43 mm per side.
5. Reference JEDEC registration MS-013.

EXAMPLE BOARD LAYOUT

DW0020A

SOIC - 2.65 mm max height

SOIC



LAND PATTERN EXAMPLE
SCALE:6X

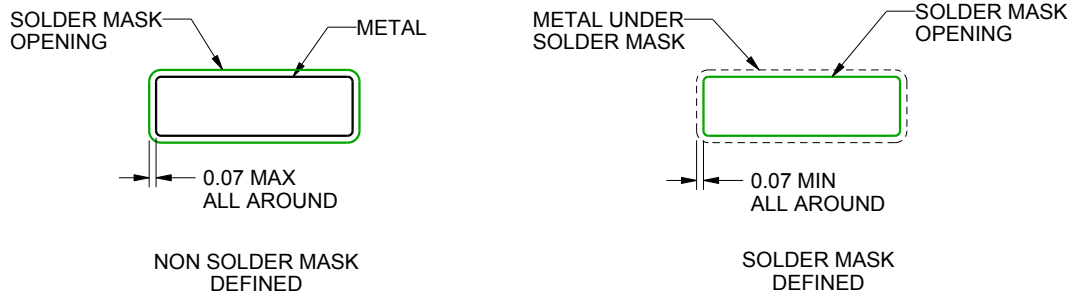

SOLDER MASK DETAILS

4220724/A 05/2016

NOTES: (continued)

- 6. Publication IPC-7351 may have alternate designs.
- 7. Solder mask tolerances between and around signal pads can vary based on board fabrication site.

EXAMPLE STENCIL DESIGN

DW0020A

SOIC - 2.65 mm max height

SOIC



SOLDER PASTE EXAMPLE
BASED ON 0.125 mm THICK STENCIL
SCALE:6X

4220724/A 05/2016

NOTES: (continued)

8. Laser cutting apertures with trapezoidal walls and rounded corners may offer better paste release. IPC-7525 may have alternate design recommendations.
9. Board assembly site may have different recommendations for stencil design.

IMPORTANT NOTICE AND DISCLAIMER

TI PROVIDES TECHNICAL AND RELIABILITY DATA (INCLUDING DATASHEETS), DESIGN RESOURCES (INCLUDING REFERENCE DESIGNS), APPLICATION OR OTHER DESIGN ADVICE, WEB TOOLS, SAFETY INFORMATION, AND OTHER RESOURCES "AS IS" AND WITH ALL FAULTS, AND DISCLAIMS ALL WARRANTIES, EXPRESS AND IMPLIED, INCLUDING WITHOUT LIMITATION ANY IMPLIED WARRANTIES OF MERCHANTABILITY, FITNESS FOR A PARTICULAR PURPOSE OR NON-INFRINGEMENT OF THIRD PARTY INTELLECTUAL PROPERTY RIGHTS.

These resources are intended for skilled developers designing with TI products. You are solely responsible for (1) selecting the appropriate TI products for your application, (2) designing, validating and testing your application, and (3) ensuring your application meets applicable standards, and any other safety, security, or other requirements. These resources are subject to change without notice. TI grants you permission to use these resources only for development of an application that uses the TI products described in the resource. Other reproduction and display of these resources is prohibited. No license is granted to any other TI intellectual property right or to any third party intellectual property right. TI disclaims responsibility for, and you will fully indemnify TI and its representatives against, any claims, damages, costs, losses, and liabilities arising out of your use of these resources.

TI's products are provided subject to TI's Terms of Sale (www.ti.com/legal/termsofsale.html) or other applicable terms available either on ti.com or provided in conjunction with such TI products. TI's provision of these resources does not expand or otherwise alter TI's applicable warranties or warranty disclaimers for TI products.

Mailing Address: Texas Instruments, Post Office Box 655303, Dallas, Texas 75265
Copyright © 2020, Texas Instruments Incorporated