

NOTES:

- MATERIALS AND FINISHES:
 - FERRULE - BRASS, GOLD PLATING
 - BODY - BRASS, GOLD PLATING
 - SHELL - STAINLESS STEEL, GOLD PLATING
 - CONTACT - BRASS, GOLD PLATING
 - RETAINER RING - BeCu, NATURAL
 - GASKET - SILICONE RUBBER, RED
 - INSULATOR - PTFE, NATURAL
- ELECTRICAL:
 - A. IMPEDANCE: 50 OHMS
 - B. DIELECTRIC WITHSTANDING VOLTAGE: 750 VRMS, MIN.
- MECHANICAL:
 - A. DURABILITY: 500 CYCLES MIN.
 - B. TEMPERATURE RANGE: -65°C TO +165°C
- CRIMPED FERRULE HEX CRIMP SIZE .128"
- CONTACT PIN TO SOLDER.
- RECOMMENDED MATING TORQUE: 3-5 IN-LBS

THIRD ANGLE PROJ.

REVISIONS

REV	DESCRIPTION	DATE	ECO	APPR
NC	INITIAL RELEASE	28-Jul-09	-----	MZ
B	SYNCH DRAWING	02-May-18	06081	MZ

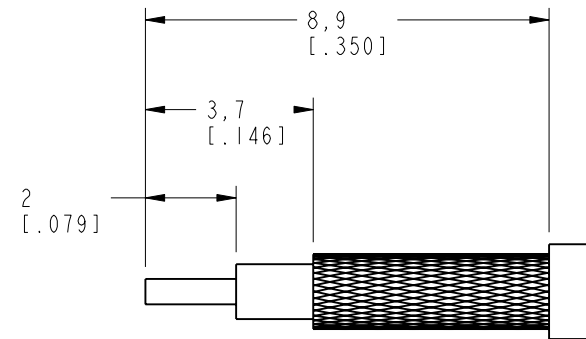

**RECOMMENDED
CABLE STRIPPING DIM'S**

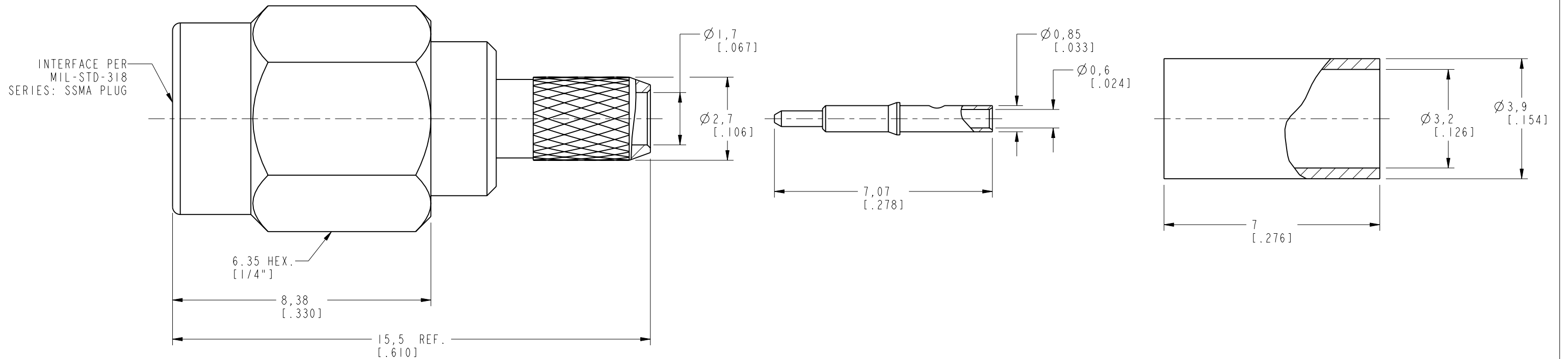
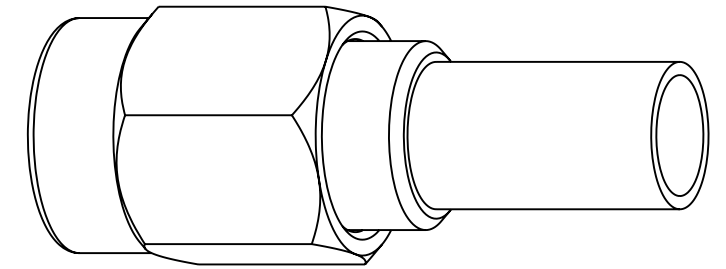

CUSTOMER OUTLINE DRAWING
ALL OTHER SHEETS ARE FOR INTERNAL USE ONLY

<p>UNLESS OTHERWISE SPECIFIED, DIMENSIONS ARE IN METRIC AND TOLERANCES ARE: <0.5mm ±0.05mm 0.5 - 6mm ±0.1mm 6 - 30mm ±0.2mm 30 - 120mm ±0.3mm ANGLES ±1°</p> <p>NOTICE - These drawings, specifications, or other data (1) are, and remain the property of Amphenol corp. (2) must be returned upon request; and (3) are confidential and not to be disclosed to any person other than those to whom they are given by Amphenol Corp. the furnishing of these drawings, specifications, or other data by Amphenol Corp., or to any other person to anyone for any purpose is not to be regarded by implication or otherwise in any manner licensing, granting rights to permitting such holder or any other person to manufacture, use or sell any product, process or design, patented or otherwise, that may in any way be related to or disclosed by said drawings, specifications, or other data.</p>	MATERIAL FALSE	DRAWN M. ZHANG	DATE 02-May-18	<p>TITLE SSMA CRIMP PLUG (FOR RG-174/U, 188A/U, 316/U CABLE)</p>	<p>Amphenol RF www.amphenolrf.com</p>		
	REFERENCE AND CONFIGURATION LEVEL: In Work	ENGINEER S. HSIEH	DATE 27-Jul-09				SCALE: 8.0:1.0 SHEET 2 OF 2
	FINISH	APPROVED S. HSIEH	DATE 02-May-18	DWG SIZE B	REV B	DRAWING NO. SSM11111A1-3GT30G-316U-50	
						ITEM NO. 141111AAA36GE5F PART NO. 133101	