

DRAWING MADE IN THIRD ANGLE PROJECTION

THIS DRAWING IS UNPUBLISHED. RELEASED FOR PUBLICATION, 19

© COPYRIGHT 1967 BY AMP INCORPORATED, HARRISBURG, PA. ALL INTERNATIONAL RIGHTS RESERVED. AMP PRODUCTS MAY BE COVERED BY U.S. AND FOREIGN PATENTS AND/OR PATENTS PENDING.

LOC FT DIST 22

| REVISIONS | | | | | |
|-----------|------|-----|------------------------------|-----------|-----------|
| P / F | ZONE | LTR | DESCRIPTION | DATE | APPROVED |
| ✓ | | D | REVISED AND REDRAWN G778 103 | 8-31-83 | H.W. Roan |
| ✓ | | E | OBS -2 & -4 PER AD1831 | 3-22-88 | LB |
| ✓ | | F | REV PER EC 0320-344-47 | 24 NOV 97 | NS |

D
C
B
A

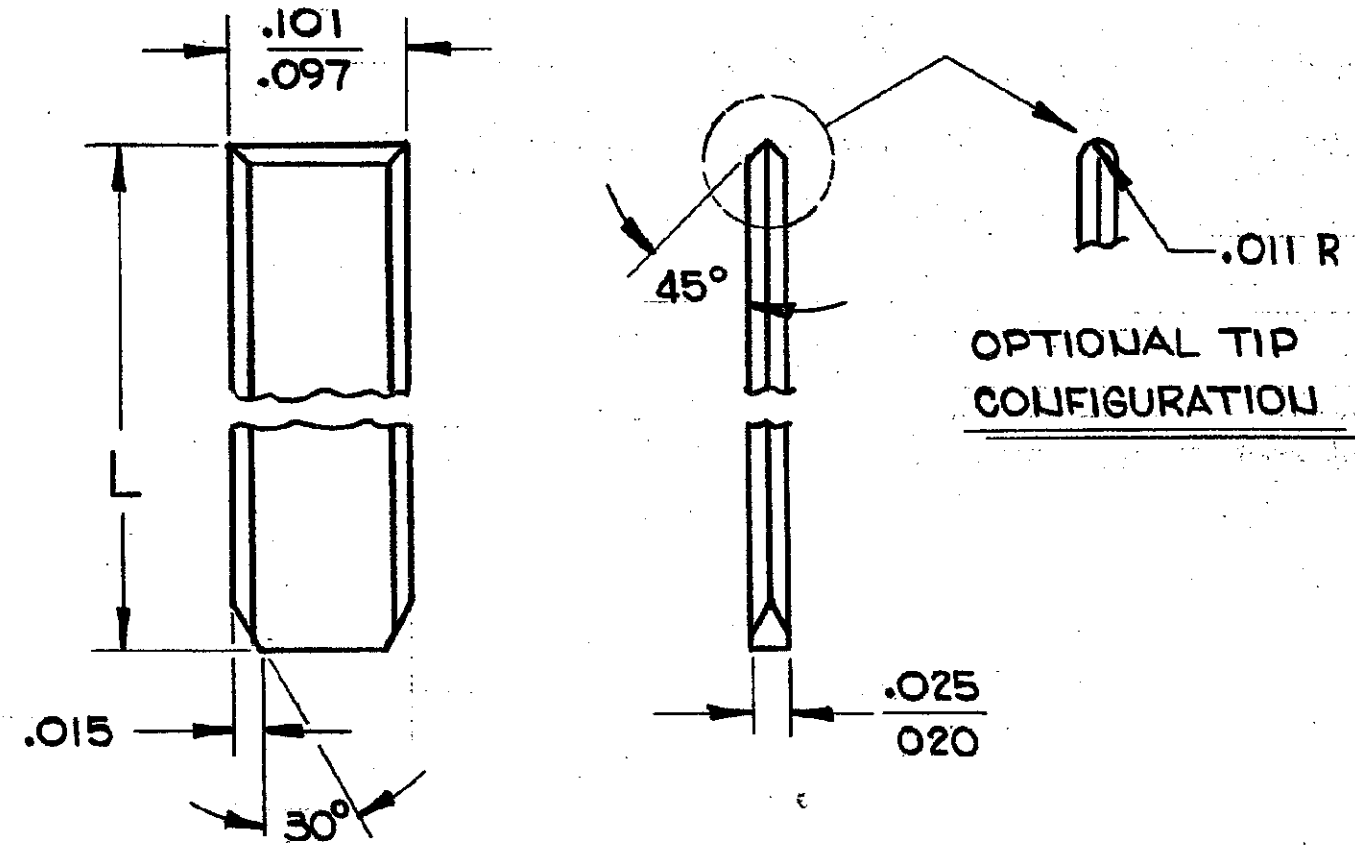

| | | | | |
|----------|------------------------|---------|-----------|----------|
| OBSOLETE | NYLON | NATURAL | .495/.485 | 583274-4 |
| | GLASS-FILLED POLYESTER | NATURAL | .295/.275 | 583274-3 |
| OBSOLETE | NYLON | YELLOW | .295/.275 | 583274-2 |
| | NYLON | NATURAL | .295/.275 | 583274-1 |
| | MATERIAL | COLOR | L | PART NO |

| | | | |
|--|------------------------------|--|------------------|
| UNLESS OTHERWISE SPECIFIED DIMENSIONS ARE IN INCHES. TOLERANCES ON: DECIMALS ±.005 ANGLES ± | CONTRACT NO | AMP INCORPORATED Harrisburg, Pa. | |
| | DR. IRSHAFFUER 8-31-83 | AMP | |
| MATERIAL SEE CHART | CHK. Howard W. Roan 8/31/83 | NAME KEY FOR AMP LEAF HOUSING, INTER-CONTACT, .020 THICK | |
| FINISH # | APPD. Howard W. Roan 8/31/83 | SIZE B | FSCM NO 00779 |
| | APPD. D.D. Swisher 2/31/85 | DRAWING NO 583274 | |
| | DSGN APPD | SCALE 10-1 | SHEET 1 OF 1 |
| | OTHER APPD | | |