

LOC	DIST	REVISIONS					
		P	LTR	DESCRIPTION	DATE	DWN	APVD
HJ	-		A4	Doc change D02309-DOK51 to C-1462034-2	30Jan2006	UKo	HD
			A5	change marking	28Jul2006	UKo	HD
			A6	REVISED PER ECO-11-005150	23MAR2011	RK	HMR
			A7	REVISED PER ECO-13-009556	14JUN2013	UKo	AK

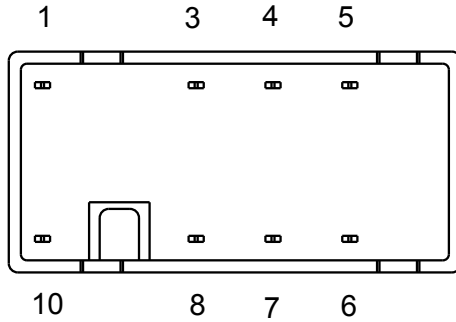

Relay - bottom view

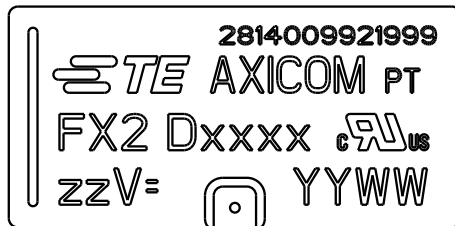
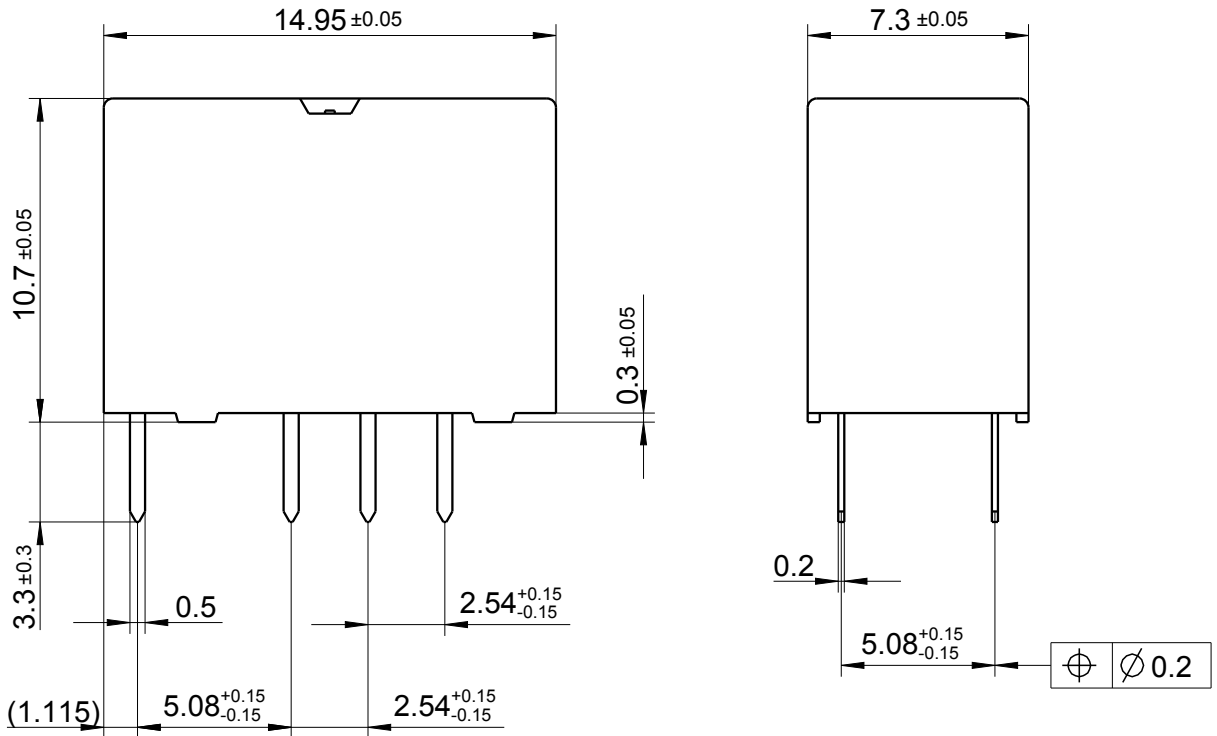

xxxx = Relay type
 ZZ = nominal voltage
 YYWW = Date code

DRAWING ALIAS: D02309-DOK51

2006

RELEASED FOR PUBLICATION

ALL RIGHTS RESERVED.

THIS DRAWING IS UNPUBLISHED.

© COPYRIGHT 2006

DIMENSIONS: mm	DWN	21MAR1995	MATERIAL	FINISH
	RG 9181		-	-
TOLERANCES UNLESS OTHERWISE SPECIFIED: DIN 7168-m	CHK	21MAR1995	TE Connectivity	
	HD 9121			
0 PLC ±- 1 PLC ±- 2 PLC ±- 3 PLC ±- 4 PLC ±- ANGLES ±-	APVD	21MAR1995	NAME FX2-Relay Dimensions	
	HD 9121			
	PRODUCT SPEC		SIZE	CAGE CODE
			A4	00779
	APPLICATION SPEC		DRAWING NO	RESTRICTED TO
			C-1462034-2	-
	WEIGHT		CUSTOMER DRAWING	
			SCALE	SHEET
			4:1	1 OF 1
			REV	A7