

THIS DRAWING IS UNPUBLISHED. RELEASED FOR PUBLICATION
 © COPYRIGHT - By - ALL RIGHTS RESERVED.

REVISIONS				
P	LTR	DESCRIPTION	DATE	APVD
B		UPDATE PER ECO-16-002588	24 FEB 16	CAS CAS

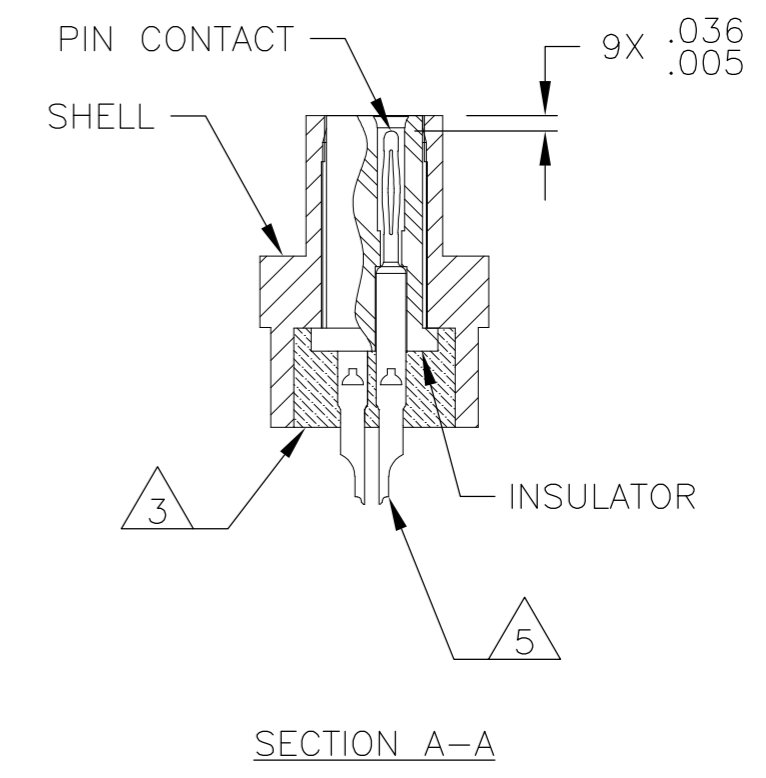
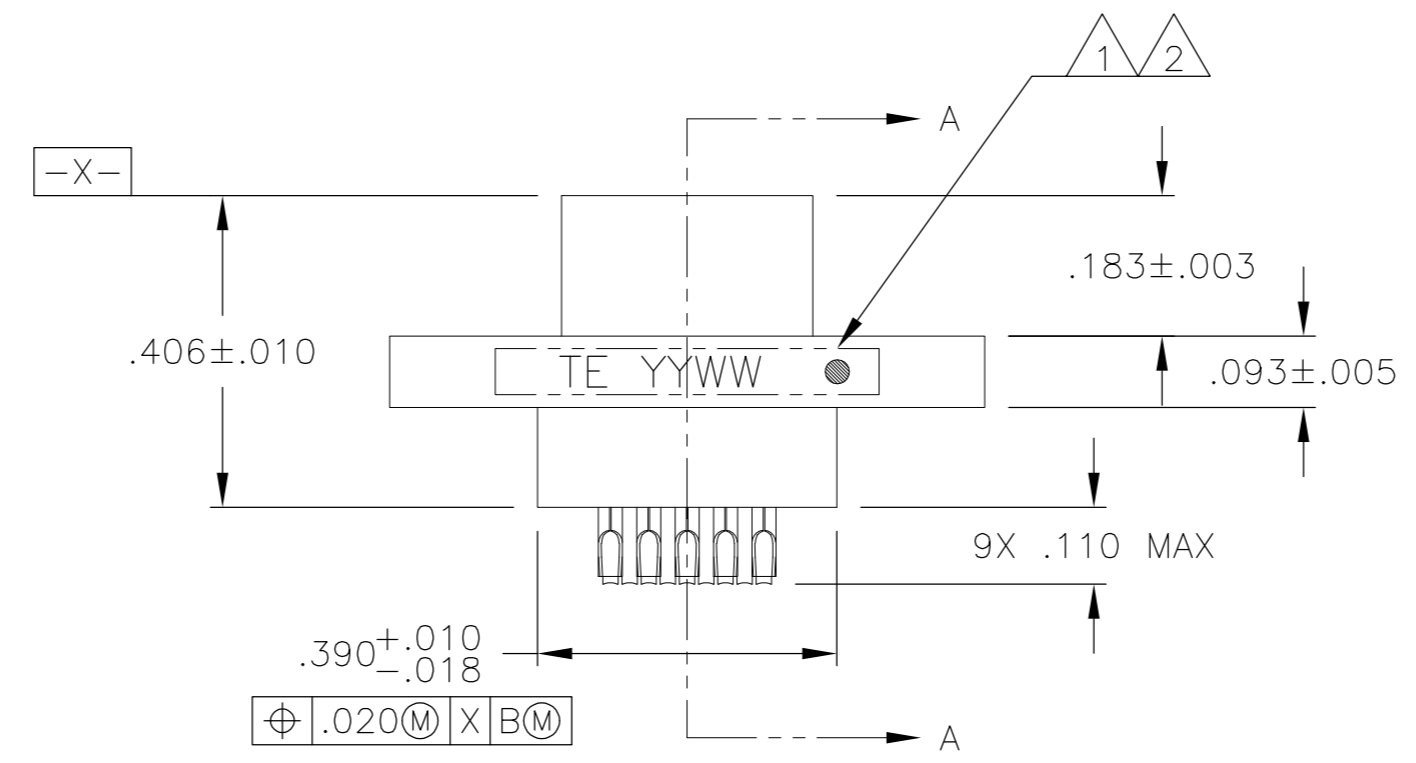
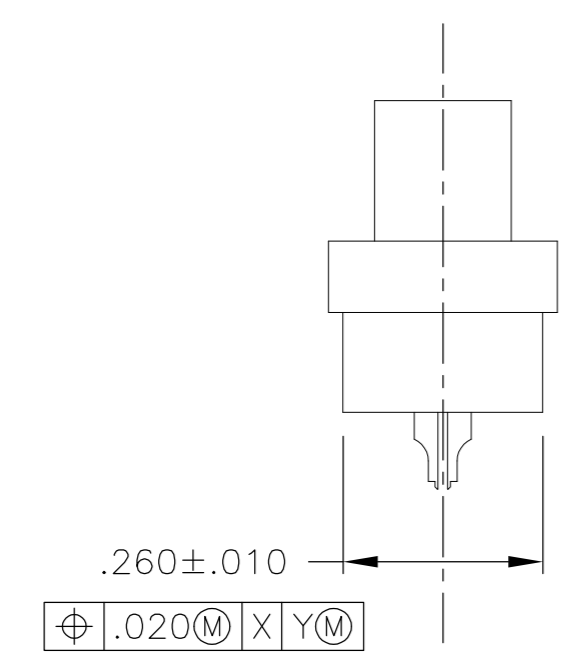
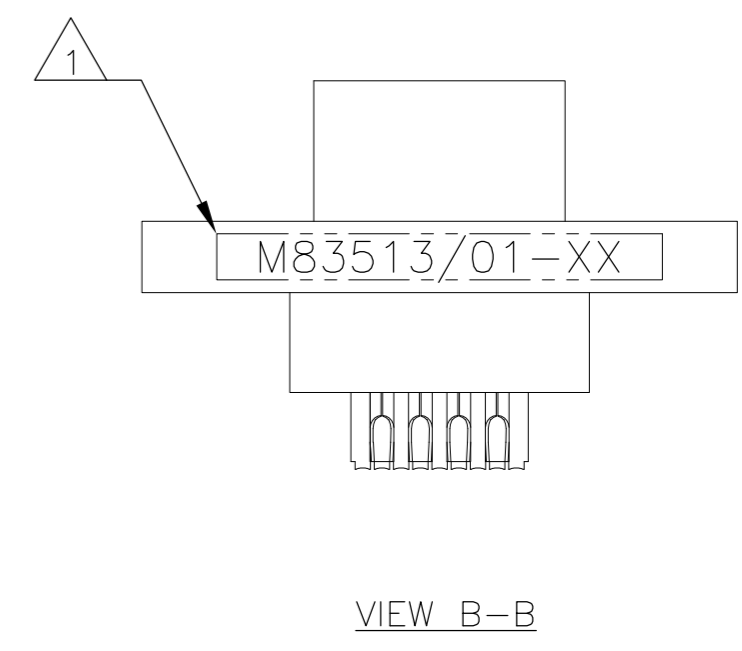
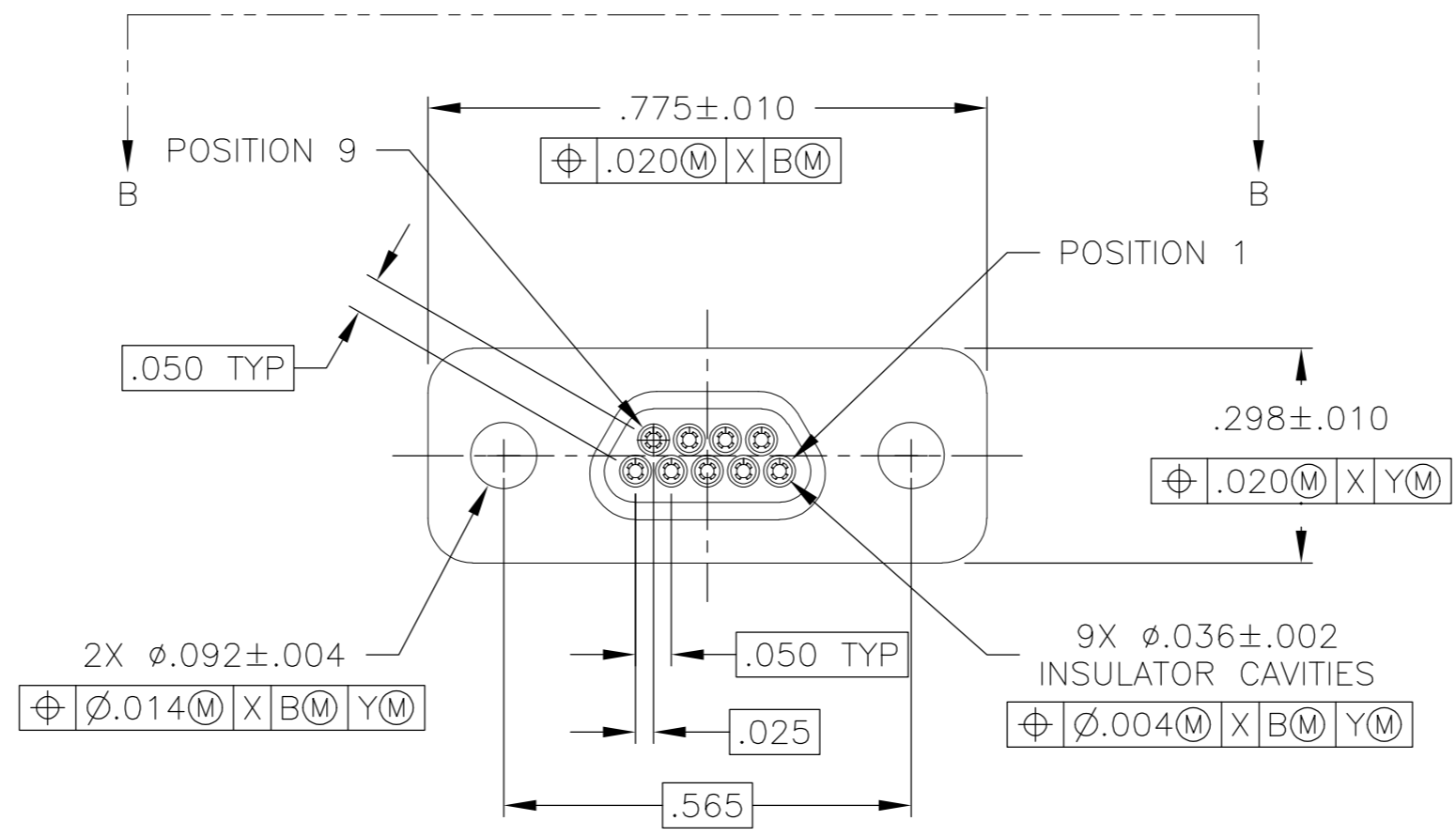
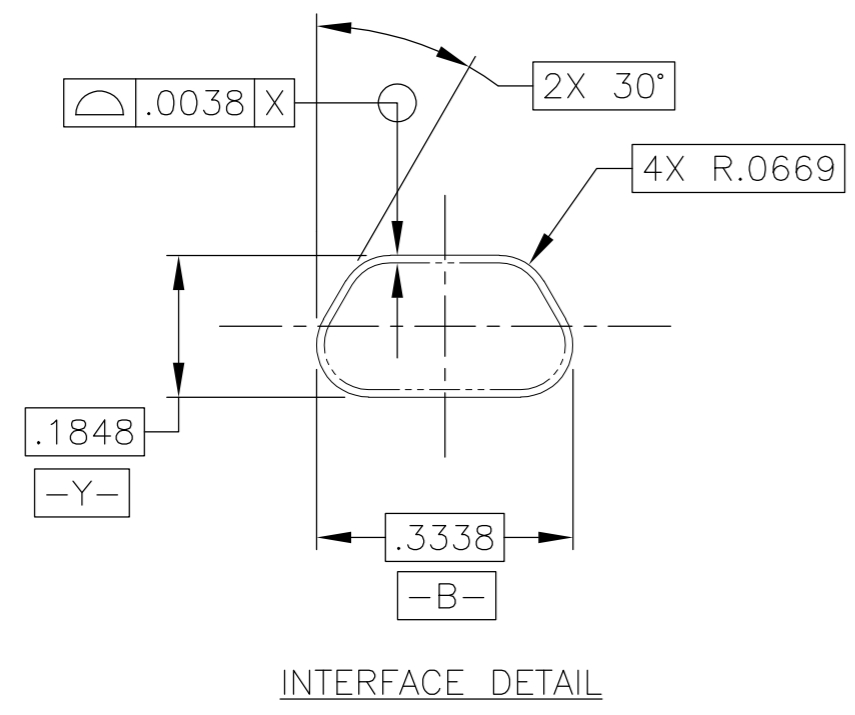

- 1 CONNECTOR SHALL BE MARKED IN ACCORDANCE WITH METHOD I OF MIL-STD-1285. MARKING SHALL CONTAIN THE MILITARY PIN, CAGE CODE (OR TE), AND DATE CODE. EXAMPLE: M83513/01-XX TE YYWW (WHERE XX IS PART OF THE PIN SHOWN IN THE "MIL-DTL-83513" COLUMN OF THE PART NUMBER TABLE, AND YYWW IS THE DATE CODE). FOR THE SIZE 9 PLUG, THE MARKING MUST BE PRINTED ON BOTH SIDES OF THE FLANGE. TEXT HEIGHT SHALL BE .035 INCH MINIMUM.
- 2 POSITION 1 SHALL BE INDICATED BY AN IDENTIFIABLE MARK, LOCATED APPROXIMATELY AS SHOWN ON THE POSITION 1 SIDE OF THE CONNECTOR FLANGE. THIS MARK SHALL BE INCLUDED AS PART OF THE PART MARKING INFORMATION.
- 3 EPOXY ENCAPSULATION. EPOXY MAY WICK .050 INCH MAX FOR SOLDER CUPS.
- 4 ALL DIMENSIONS AND REQUIREMENTS ARE PER MIL-DTL-83513/1
- 5 CHAMFER ON SOLDER POTS ARE PARALLEL WITH THE SIDE OF CONNECTOR WITHIN 10°

THIS DRAWING IS A CONTROLLED DOCUMENT.		DWN B. ROMANCHUK 03 SEP 08		
DIMENSIONS: INCHES		CHK M. STORRY 03 SEP 08		
TOLERANCES UNLESS OTHERWISE SPECIFIED:		NAME PLUG ASSEMBLY, MICRO-D PER MIL-DTL-83513/01, MCKS SERIES, 9 POSITION		
0 PLC ± - 1 PLC ± - 2 PLC ± .010 3 PLC ± .005 4 PLC ± - ANGLES ± 1°		PRODUCT SPEC APPLICATION SPEC		
MATERIAL SEE NOTES		FINISH -		
		WEIGHT -	SIZE A2	CAGE CODE 98278
		DRAWING NO 1532209		RESTRICTED TO -
CUSTOMER DRAWING		SCALE 4:1	SHEET 1 of 2	REV B

