

©1964 BY AMP INCORPORATED. ALL RIGHTS RESERVED. AMP PRODUCTS COVERED BY PATENTS AND/OR PATENTS PENDING.

REVISIONS

SYM	ZONE	DESCRIPTION	DATE	APPROVAL
O		RELEASED WAS M5001-529	7/21/64	KJ/DSTH
A		REVISED V-291	7/30/64	KJ/DM
B		REMOVE PROPOSED DESIGN STAMP W-530	7-23-65	M.S. DM
C		ADD -Z Y-890	1-10-67	KJ/DM
D		REV PER PHIA-0241-05	04-05	AP/OE
E		REV PER ECO-05-005359	11-05	PY/OE

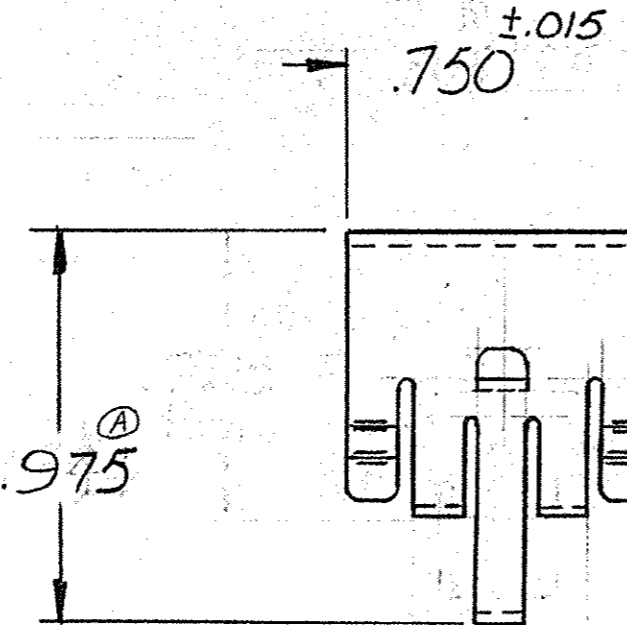
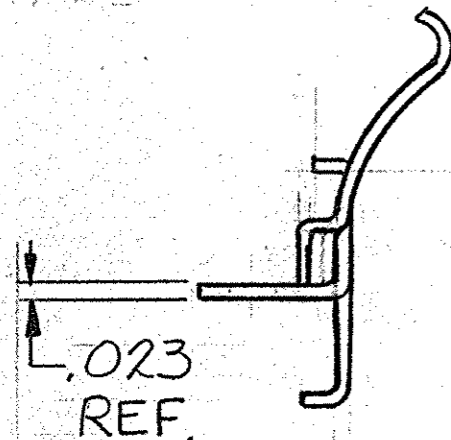
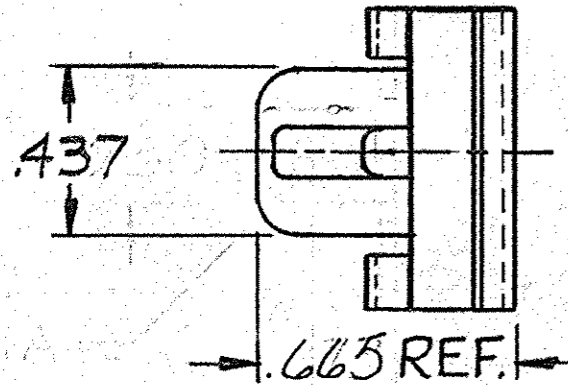

SUPERSEDED BY 5--2

- 202577-1  $\Delta$  3 1. AS SHOWN
- 202577-2  $\Delta$  3 1. SAME AS -1 EXCEPT:  
2. ASS'Y INCLUDES (2) SCREWS,  
(2) LOCKWASHERS & (2) NUTS
- 5-202577-2  $\Delta$  4 1. AS SHOWN
1. (2) LOCKING SPRINGS PACKAGED PER UNIT.  
2. FOR MATING CATCH SEE 202576.
- $\Delta$  3 ELECTROLESS NICKEL PLATE PER SAE-AMS-C-2607A  
.00002 - .000022 THK.
- $\Delta$  4 ELECTROLESS NICKEL PLATE PER SAE-AMS-C-2607A  
.00002 - .000022 THK (NO INTENTIONAL ADDITIONS OF  
LEAD OR CADMIUM PER DFE STANDARD 230-700).

QTY	PART OR REQD IDENTIFYING NO.	NOMENCLATURE OR DESCRIPTION
LIST OF MATERIALS OR PARTS LIST		
UNLESS OTHERWISE SPECIFIED DIMENSIONS ARE IN INCHES TOLERANCES ON		SIGNATURE DR <i>K. Jones</i> 3/18/64 CHK <i>D.S. Heide</i> 7/22/64 DSGN ENGR <i>J. Dellystone</i> 7-22-64 APPR <i>W. Curtis</i> 7/22/64
FRACTIONS ±	DECIMALS ±.005	
MATERIAL STEEL		DATE 3/18/64 7/22/64 7-22-64 7/22/64
HEAT TREAT — / — / —		
FINISH ELECTROPLATE		AMP INCORPORATED HARRISBURG, PENNSYLVANIA  LOCKING SPRING SERIES "G"
AMP INFO LOC PRINT DIST R 39 E		
CODE IDENT NO 00779		SIZE B
NUMBER 202577-2		
SCALE 2-1	WT	CALC ACTUAL SHEET

CUSTOMER DRAWING