

THIS DRAWING IS UNPUBLISHED. RELEASED FOR PUBLICATION
 © COPYRIGHT - By - ALL RIGHTS RESERVED.

PROD 3346 CODE	LOC DF	DIST X0	REVISIONS					
			P	LTR	DESCRIPTION	DATE	DWN	APVD
			M1		ECR-12-005726	27MAR12	RK	MY

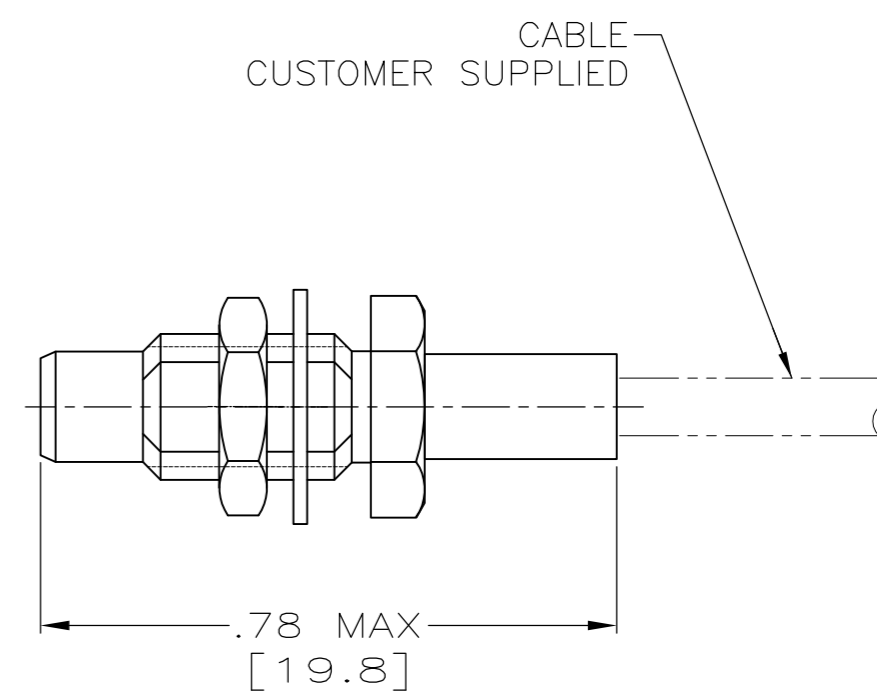
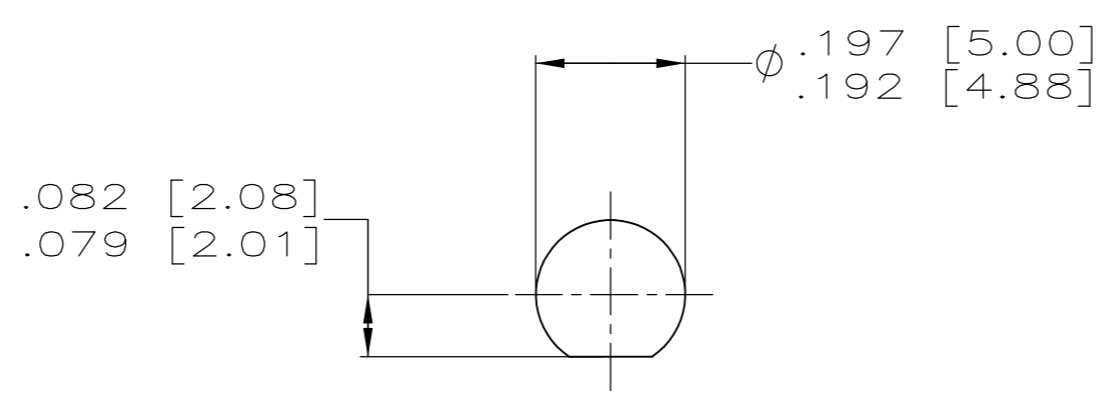
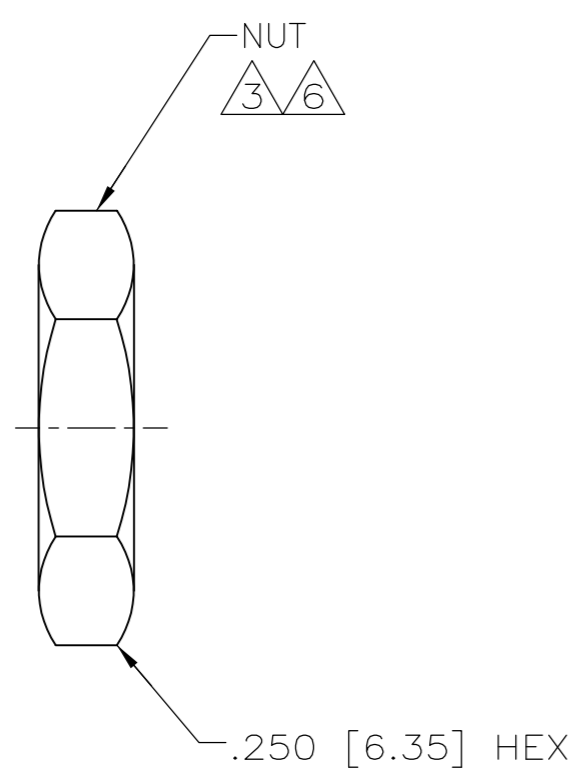
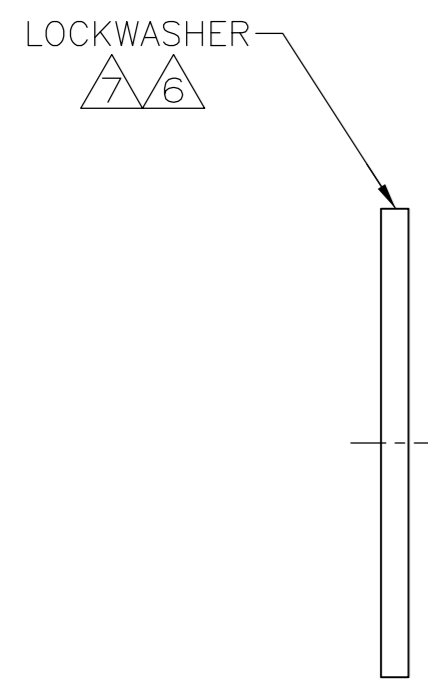
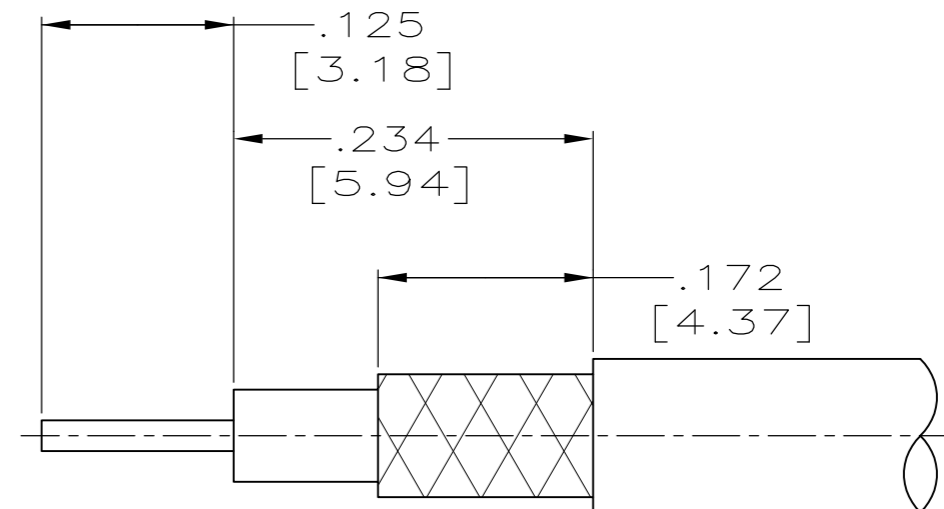
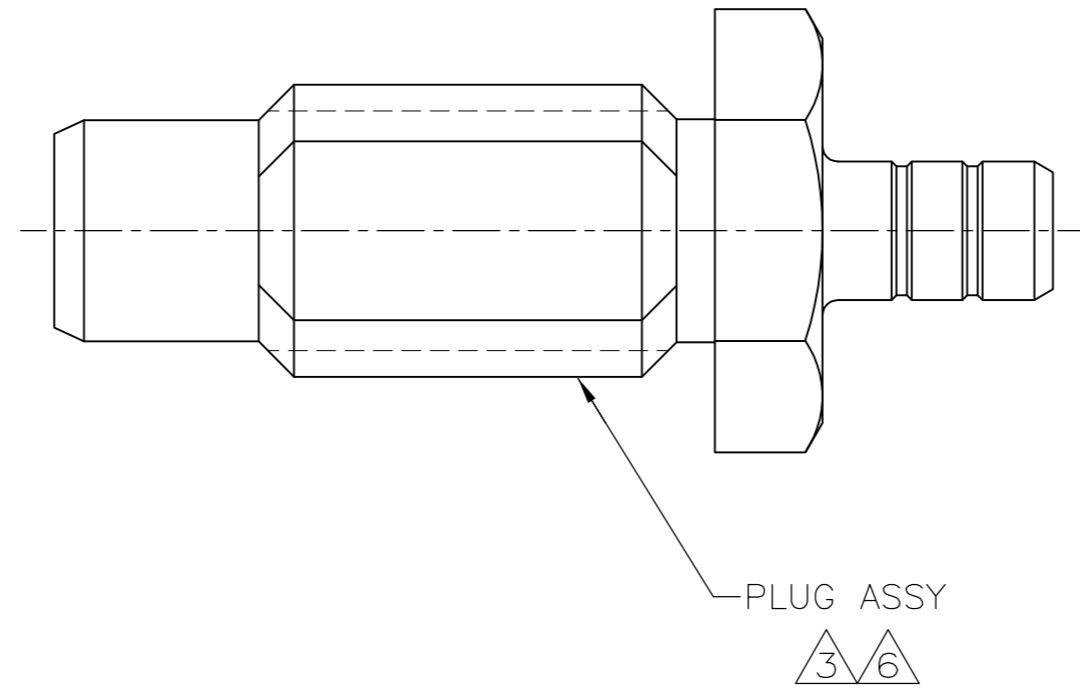
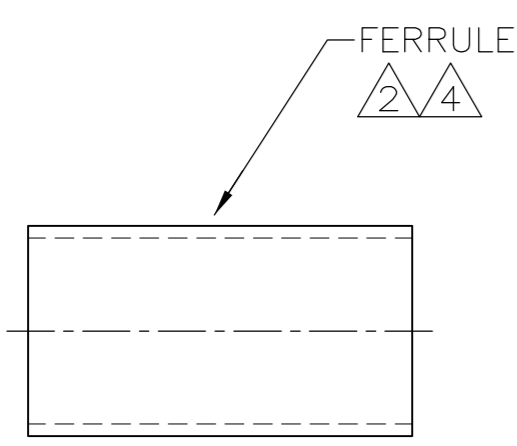
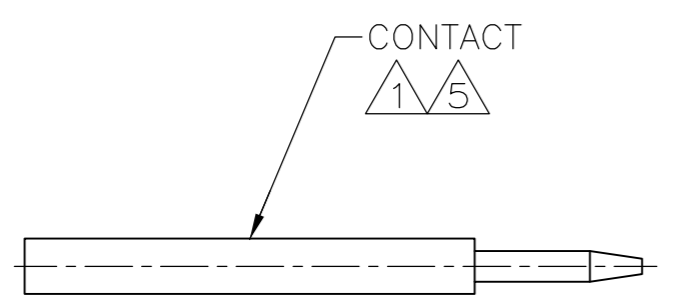

- ① MAT'L: BERYLLIUM COPPER PER ASTM-B-196.
- ② MAT'L: COPPER PER ASTM-B-152.
- ③ MAT'L: BRASS PER ASTM-B-16.
- ④ FINISH: MATTE TIN PLATED PER MIL-T-10727.
- ⑤ FINISH: GOLD PLATE PER MIL-G-45204 OVER NICKEL PER QQ-N-290.
- ⑥ FINISH: GOLD PLATE PER MIL-G-45204 OVER COPPER PER MIL-C-14550.
- △ MAT'L: PHOPHOR BRONZE PER QQ-B-750.
- 8. DIELECTRICS ARE PTFE PER MIL-P-19468.
- 9. CRIMP WITH TOOL #220020-1; SEE I.S.2224.
- 10. FOR USE WITH RG-174 AND 188 COAX CABLE.

51751-1
PART NO.

THIS DRAWING IS A CONTROLLED DOCUMENT.		DWN C.C.THOMAS 8-5-93	TE Connectivity	
DIMENSIONS: mm [INCHES]		CHK J.CABARLO 9-7-93		
TOLERANCES UNLESS OTHERWISE SPECIFIED:		APVD J.CABARLO 9-7-93	NAME	
0 PLC ± - 1 PLC ± - 2 PLC ± - 3 PLC ± .015 [0.38] 4 PLC ± - ANGLES ± -		PRODUCT SPEC	COAXICON-SMC,BULKHEAD JACK KIT,RF	
MATERIAL SEE CALLOUTS		FINISH SEE CALLOUTS	WEIGHT -	RESTRICTED TO
		SIZE A2	CAGE CODE 00779	DRAWING NO 51751-1
		CUSTOMER DRAWING		SCALE 8:1
		SHEET 1 of 1		REV M1