

PART NUMBER	REV	TERMINATOR	FEED TYPE	DESCRIPTION
1426589-1	A	LEADMAKER	MECH POST FEED	CUTS CARRIER
1426589-2	A	BENCH	MECH PRE FEED	CUTS CARRIER
1426589-6	A	LEADMAKER	MECH POST FEED	CONTINUOUS CARRIER
7-1426589-1	A	LEADMAKER	MECH POST FEED	-1 AND SPARE PARTS
7-1426589-2	A	BENCH	MECH PRE FEED	-2 AND SPARE PARTS
7-1426589-6	A	LEADMAKER	MECH POST FEED	-6 AND SPARE PARTS
7-1426589-7	A	-	-	SPARE PARTS KIT

CRIMP DATA		JST TERMINAL	TYCO CRIMP SPECS
TERMINAL NAME: XH CONNECTOR			
CRIMP	SIZE	TYPE	RANGE
WIRE	1.07 [0.042 IN]	F	0.05-0.13mm ² or 30-26 AWG
INSUL	1.78 [0.070 IN]	F	0.90-1.30 [0.035-.051 IN]
WIRE STRIP LENGTH 1.75-2.26 [0.069-.089 IN]		APPL INSTRUCTIONS 408-8322	
TERMINAL APPL SPEC	NONE	FEED	8.50 [0.335 IN]
TERMINALS APPLIED			
TYCO PN	MANUF PN		
1572904-1	SXH-002T-P0.6		
WIRE SIZE	CRIMP HEIGHT	PINPN & LENGTH [IN]	
0.15 mm ²	0.69 ±0.05 [0.027 ±0.002 IN]	6-354779-2 [0.3300]	

- △ RECOMMENDED SPARE PARTS.
- 2. GREASE RAM, CAM, CAM FOLLOWER AND FEED ROD LIGHTLY.
- △ CERTAIN TERMINALS REQUIRE LUBRICATION. REFER TO THE APPLICATOR INSTRUCTION SHEET FOR MORE INFORMATION.
- 4. LUBRICATE DAILY PER THE APPLICATOR INSTRUCTION SHEET SUPPLIED WITH THE APPLICATOR.
- △ WIRE & INS RANGES SHOWN ARE THAT OF THE TERMINAL.
- △ ALL CRIMP DATA CALCULATED BY TYCO ELECTRONICS UK LTD. WIRE SIZE 0.15mm² IS THAT REQUESTED BY THE ORIGINAL CUSTOMER.

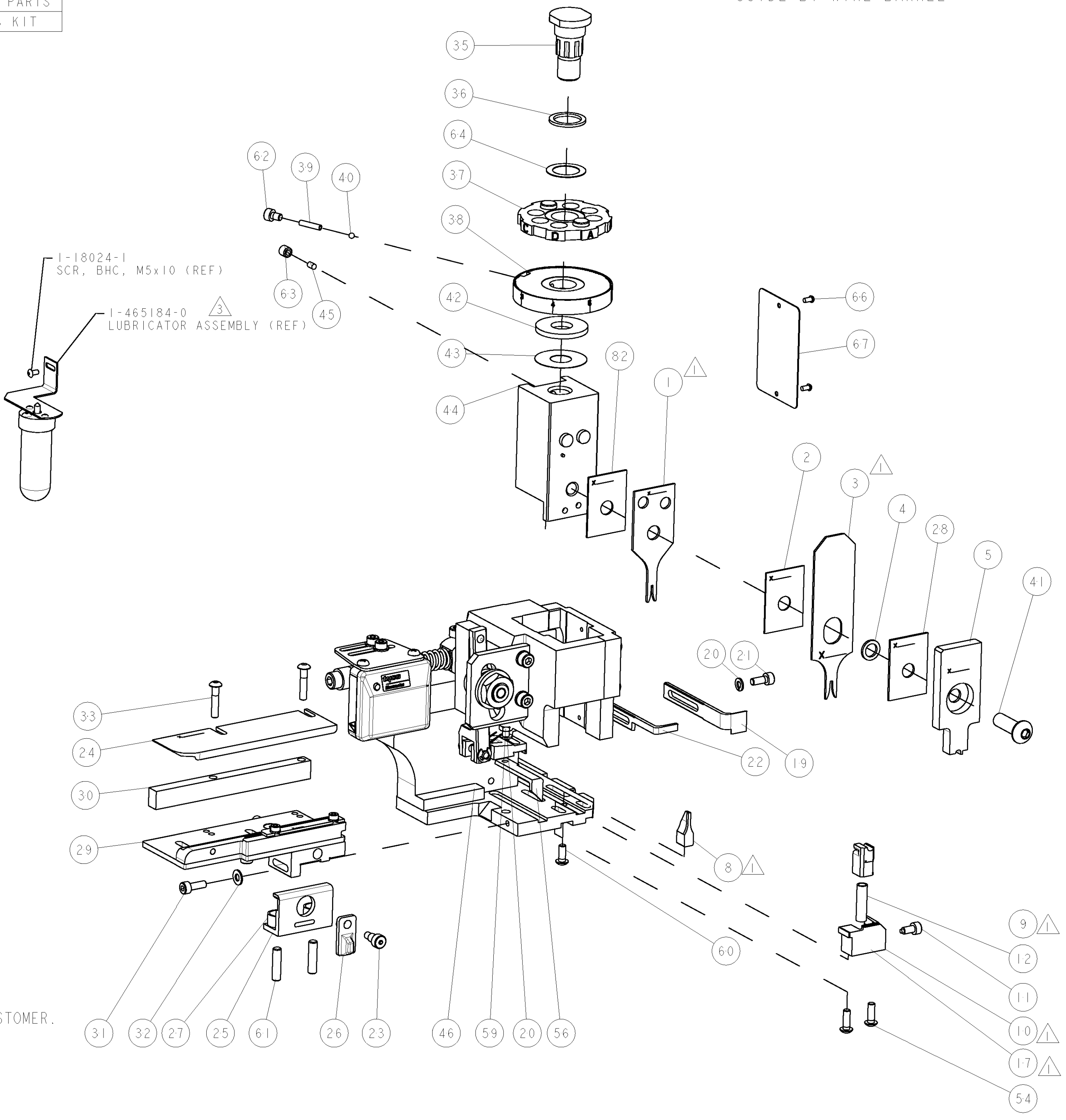
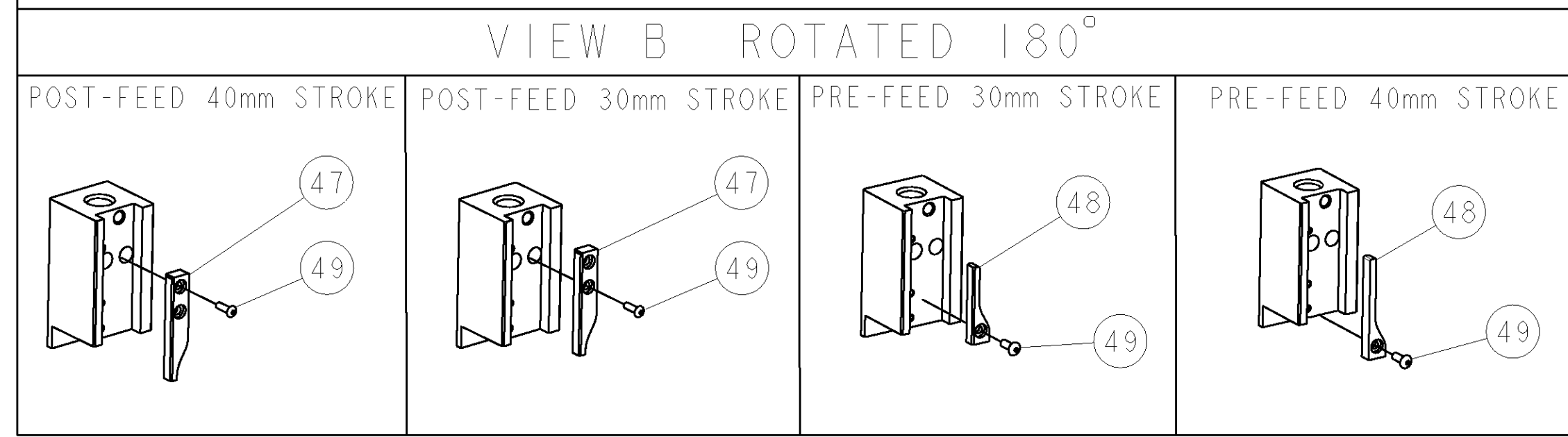

SET UP GAGE 458637-3		LOC	DIST	REVISIONS			
A	66			REV	DATE	BY	APPD
				A	26JAN2006	LJL	MC

REV	DATE	BY	APPD	DESCRIPTION	ITEM NO				
-	-	-	-	-	73				
-	-	-	-	-	72				
-	-	-	-	-	71				
-	-	-	-	-	70				
-	-	-	-	-	69				
-	-	-	-	-	68				
-	-	-	-	-	67				
-	-	-	-	-	66				
-	-	-	-	-	65				
-	-	-	-	-	64				
-	-	-	-	-	63				
-	-	-	-	-	62				
-	-	-	-	-	61				
-	-	-	-	-	60				
-	-	-	-	-	59				
-	-	-	-	-	58				
-	-	-	-	-	57				
-	-	-	-	-	56				
-	-	-	-	-	55				
-	-	-	-	-	54				
-	-	-	-	-	53				
-	-	-	-	-	52				
-	-	-	-	-	51				
-	-	-	-	-	50				
-	-	-	-	-	49				
-	-	-	-	-	48				
-	-	-	-	-	47				
-	-	-	-	-	46				
-	-	-	-	-	45				
-	-	-	-	-	44				
-	-	-	-	-	43				
-	-	-	-	-	42				
-	-	-	-	-	41				
-	-	-	-	-	40				
-	-	-	-	-	39				
-	-	-	-	-	38				
-	-	-	-	-	37				
-	-	-	-	-	36				
-	-	-	-	-	35				
-	-	-	-	-	34				
-	-	-	-	-	33				
-	-	-	-	-	32				
-	-	-	-	-	31				
-	-	-	-	-	30				
-	-	-	-	-	29				
-	-	-	-	-	28				
-	-	-	-	-	27				
-	-	-	-	-	26				
-	-	-	-	-	25				
-	-	-	-	-	24				
-	-	-	-	-	23				
-	-	-	-	-	22				
-	-	-	-	-	21				
-	-	-	-	-	20				
-	-	-	-	-	19				
-	-	-	-	-	18				
-	-	-	-	-	17				
-	-	-	-	-	16				
-	-	-	-	-	15				
-	-	-	-	-	14				
-	-	-	-	-	13				
-	-	-	-	-	12				
-	-	-	-	-	11				
-	-	-	-	-	10				
-	-	-	-	-	9				
-	-	-	-	-	8				
-	-	-	-	-	7				
-	-	-	-	-	6				
-	-	-	-	-	5				
-	-	-	-	-	4				
-	-	-	-	-	3				
-	-	-	-	-	2				
-	-	-	-	-	1				
-77	-76	-72	-71	-6	-2	-1	PART NO	DESCRIPTION	ITEM NO
-	-	-	-	-	-	-	455888-8	SPACER, CRIMPER	82
-	-	-	-	-	-	-	-	-	81
-	-	-	-	-	-	-	-	-	80
-	-	-	-	-	-	-	-	-	79
-	-	-	-	-	-	-	-	-	78
-	-	-	-	-	-	-	-	-	77
-	-	-	-	-	-	-	-	-	76
-	-	-	-	-	-	-	-	-	75
-	-	-	-	-	-	-	-	-	74
-77	-76	-72	-71	-6	-2	-1	PART NO	DESCRIPTION	ITEM NO

REV	DATE	BY	APPD	DESCRIPTION	ITEM NO
-	-	-	-	-	84
-	-	-	-	-	83
-	-	-	-	-	82
-	-	-	-	-	81
-	-	-	-	-	80
-	-	-	-	-	79
-	-	-	-	-	78
-	-	-	-	-	77
-	-	-	-	-	76
-	-	-	-	-	75
-	-	-	-	-	74

REV	DATE	BY	APPD	DESCRIPTION	ITEM NO
-	-	-	-	-	84
-	-	-	-	-	83
-	-	-	-	-	82
-	-	-	-	-	81
-	-	-	-	-	80
-	-	-	-	-	79
-	-	-	-	-	78
-	-	-	-	-	77
-	-	-	-	-	76
-	-	-	-	-	75
-	-	-	-	-	74

REV	DATE	BY	APPD	DESCRIPTION	ITEM NO
-	-	-	-	-	84
-	-	-	-	-	83
-	-	-	-	-	82
-	-	-	-	-	81
-	-	-	-	-	80
-	-	-	-	-	79
-	-	-	-	-	78
-	-	-	-	-	77
-	-	-	-	-	76
-	-	-	-	-	75
-	-	-	-	-	74

REV	DATE	BY	APPD	DESCRIPTION	ITEM NO
-	-	-	-	-	84
-	-	-	-	-	83
-	-	-	-	-	82
-	-	-	-	-	81
-	-	-	-	-	80
-	-	-	-	-	79
-	-	-	-	-	78
-	-	-	-	-	77
-	-	-	-	-	76
-	-	-	-	-	75
-	-	-	-	-	74

REV	DATE	BY	APPD	DESCRIPTION	ITEM NO
-	-	-	-	-	84
-	-	-	-	-	83
-	-	-	-	-	82
-	-	-	-	-	81
-	-	-	-	-	80
-	-	-	-	-	79
-	-	-	-	-	78
-	-	-	-	-	77
-	-	-	-	-	76
-	-	-	-	-	75
-	-	-	-	-	74

REV	DATE	BY	APPD	DESCRIPTION	ITEM NO
-	-	-	-	-	84
-	-	-	-	-	83
-	-	-	-	-	82
-	-	-	-	-	81
-	-	-	-	-	80
-	-	-	-	-	79
-	-	-	-	-	78
-	-	-	-	-	77
-	-	-	-	-	76
-	-	-	-	-	75
-	-	-	-	-	74

REV	DATE	BY	APPD	DESCRIPTION	ITEM NO
-	-	-	-	-	84
-	-	-	-	-	83
-	-	-	-	-	82
-	-	-	-	-	81
-	-	-	-	-	80
-	-	-	-	-	79
-	-	-	-	-	78
-	-	-	-	-	77
-	-	-	-	-	76
-	-	-	-	-	75
-	-	-	-	-	74

REV	DATE	BY	APPD	DESCRIPTION	ITEM NO
-	-	-	-	-	84
-	-	-	-	-	83
-	-	-	-	-	82
-	-	-	-	-	81
-	-	-	-	-	80
-	-	-	-	-	79
-	-	-	-	-	78
-	-	-	-	-	77
-	-	-	-	-	76
-	-	-	-	-	75
-	-	-	-	-	74

REV	DATE	BY	APPD	DESCRIPTION	ITEM NO
-	-	-	-	-	84
-	-	-	-	-	83
-	-	-	-	-	82
-	-	-	-	-	81
-	-	-	-	-	80
-	-	-	-	-	79
-	-	-	-	-	78
-	-	-	-	-	77
-	-	-	-	-	76
-	-	-	-	-	75
-	-	-	-	-	74

REV	DATE	BY	APPD	DESCRIPTION	ITEM NO
-	-	-	-	-	84
-	-	-	-	-	83
-	-	-	-	-	82
-	-	-	-	-	81
-	-	-	-	-	80
-	-	-	-	-	79
-	-	-	-	-	78
-	-	-	-	-	77
-	-	-	-	-	76
-	-	-	-	-	75
-	-	-	-	-	74

REV	DATE	BY	APPD	DESCRIPTION	ITEM NO
-	-	-	-	-	84
-	-	-	-	-	83
-	-	-	-	-	82
-	-	-	-	-	81
-	-	-	-	-	80
-	-	-	-	-	79
-	-	-	-	-	78
-	-	-	-	-	77
-	-	-	-	-	76
-	-	-	-	-	75
-	-	-	-	-	74

REV	DATE	BY	APPD	DESCRIPTION	ITEM NO
-	-	-	-	-	84
-	-	-	-	-	83
-	-	-	-	-	82
-	-	-	-	-	81
-	-	-	-	-	80
-	-	-	-	-	79
-	-	-	-	-	78
-	-	-	-	-	77
-	-	-	-	-	76
-	-	-	-	-	75
-	-	-	-	-	74

REV	DATE	BY	APPD	DESCRIPTION	ITEM NO
-	-	-	-	-	84
-	-	-	-	-	83
-	-	-	-	-	82
-	-	-	-	-	81
-	-	-	-	-	80
-	-	-	-	-	79
-	-	-	-	-	78
-	-	-	-	-	77
-	-	-	-	-	76
-	-	-	-	-	75
-	-	-	-	-	74

REV	DATE	BY	APPD	DESCRIPTION	ITEM NO
-	-	-	-	-	84
-	-	-	-	-	83
-	-	-	-	-	82
-	-	-	-	-	81
-	-	-	-	-	80
-	-	-	-	-	79
-	-	-	-	-	78
-	-	-	-	-	77
-	-	-	-	-	76
-	-	-	-	-	75
-	-	-	-	-	74

REV	DATE	BY	APPD	DESCRIPTION	ITEM NO
-	-	-	-	-	84
-	-	-	-	-	83
-	-	-	-	-	82
-	-	-	-	-	81
-	-	-	-	-</	