

THESE DRAWINGS ARE THE PROPERTY OF QUALTEK ELECTRONICS AND NOT TO BE REPRODUCED FOR OR COMMUNICATED TO A THIRD PARTY WITHOUT THE EXPRESS WRITTEN PERMISSION OF AN OFFICER OF QUALTEK ELECTRONICS.

REVISION			
REV.	DESCRIPTION	DATE	APPROVED
B	RoHS Compliancy	06-01-06	DP

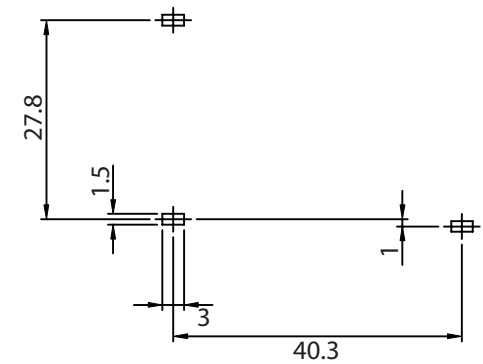
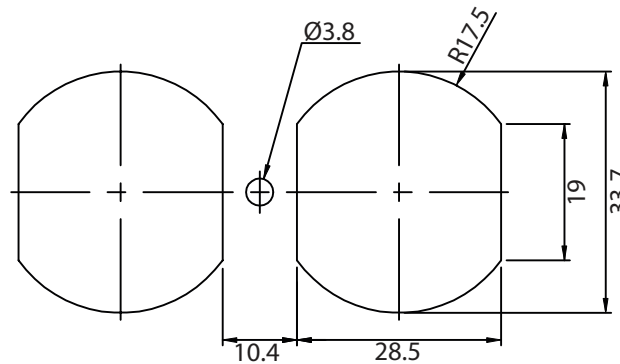
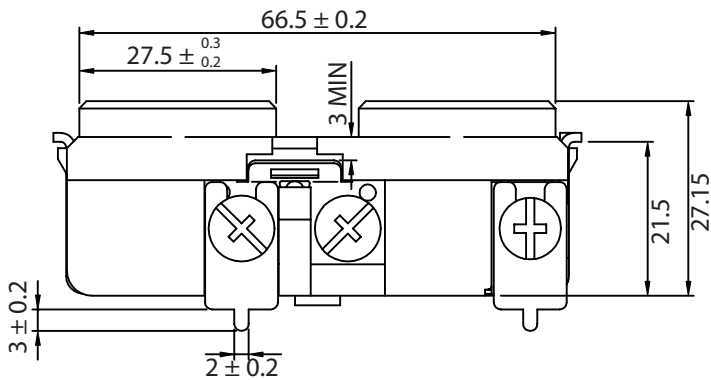
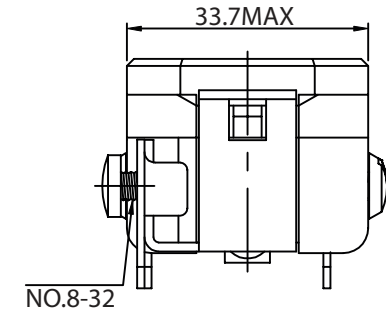
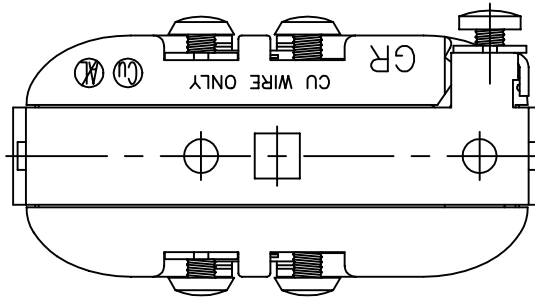
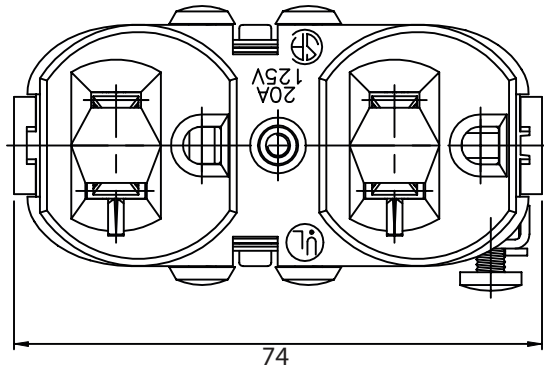

PANEL CUTOUT

P.C.B. LAYOUT

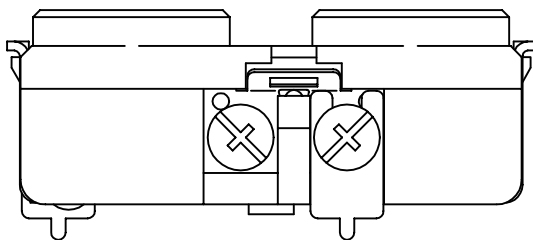

NOTES:

- USE SOLID COPPER WIRE ONLY
- RATING: 20A 125V
- STRAP-W/OUT PLASTER EARS, NO MTG.SCR.
- SIDE WIRE
- MOLD GATE MARKS PERMISSIBLE
- TERMINAL SCREWS-IN ARE OPTIONAL
- COMBINATION HEAD SCREWS ARE OPTIONAL
- HOUSING: BLACK
- APPROVALS: UL,CSA
- RoHS COMPLIANT

**CONTROLLED**

Dim range (mm)		Tolerance +/- (mm)	Qualtek Electronics Corp. PPC DIVISION		
0-1		0.15	Part Number: 740W-F/02		RoHS Compliant
1-6		0.20	Description: AC RECEPTACLE		
6-18		0.30	UNIT: mm		REV. B
18-50		0.50	Drawn / Date		Checked / Date
50-120		0.70	S.Chen 03-17-00		Approved / Date
120-250		0.90	03-17-00		JJH / 03-17-00
250-500		1.20			