

## Operation manual



Digital modified sine wave inverter



Before installing the product, read this manual thoroughly to install and use safely.  
Test reports for each model are included (3page).

## Operation manual procedure

### PAGE Contents

02 Product features

03 Specifications for each model

04 DC12V, 24V, 48V Input(Battery) / Equipment(Output power) Connection

05 Function code / Use the function description

06 Use the function description

07 Caution

08 Warranty

## Product features

- Product Configuration : It is a cutting-edge device configured with original technologies of circuit-operation and connection parts with various patents and licences.
- High stability with 95% maximum efficiency (DC 24V) and 85% of max output efficiency.
- Highly competitive Prices : parallel output operation by original technology.
- Main feature : Smart auto protect controlled by software, High efficiency power by an parallel output circuit, Auto input (DC)/output (AC) control circuits, Auto surge output control by output(AC) sensor

## AIMS Power™ Specifications for each model

NO.	PARAMETER	PWRIG500012W	PWRIG700024W	PWRIG700048W	PWRIG700024024	PWRIG700024048	LIMIT	
		(12Vdc~120Vac)	(24Vdc~120Vac)	(48Vdc~120Vac)	(24Vdc~240Vac)	(48Vdc~240Vac)		
1	DC input voltage	12V	24V	48V	24V	48V	DC12.0V~16.8V·DC21.0V~30.0V·DC42.0V~60.0V	
2	DC input voltage standard	13.4V	26.8V	53.0V	26.8V	53.0V	DC13.4V±5%·DC26.8V±5%·DC53.0V±3%	
3	Output voltage no load	AC120V	AC120V	AC120V	AC245V	AC245V	AC120V±5%·AC245V±5%	
4	Max output power	5000W	7000W				±10%	
5	Output power continuous	3600W	5600W	5300W	5600W	5300W	±5%	
6	Surge rating	10KW	14KW				±10%	
7	Efficiency et rated power	89%	91%				±3%	
8	Efficiency et max power	83%	88%	87%	88%	87%	±3%	
9	THD[max]	25%					MAX	
10	No load current	no fan	0.58A	0.60A	0.30A	0.60A	0.18A	±0.1A
		on fan	1.74A	1.10A	0.66A	1.30A	0.66A	
11	Low battery shut down	10.0V	20.0V	40.0V	20.0V	40.0V	DC10.0V±0.5V·DC20.0V±1.0V·DC40.0V±1.0V	
12	Low battery return on power	11.2V	22.0V	44.0V	22.0V	44.0V	DC11.2V±0.5V·DC22.0V±1.0V·DC44.0V±1.0V	
13	High battery shut down	17.0V	31.0V	60.8V	31.0V	60.8V	DC17.0V±1.0V·DC31.0V±1.5V·DC60.8V±1.5V	
14	High battery return on power	15.0V	28.0V	56.0V	28.0V	56.0V	DC15.0V±0.8V·DC28.0V±1.0V·DC56.0V±1.0V	
15	Frequency selection[50hz/60hz]	60hz (50hz/60hz select switch)						±0.8hz
16	Regulation	Max ±10%						±10%
17	Over temperature protection	-25°C~+76°C						80°C±5°C
18	Over temperature power on	58°C						60°C±5°C
19	Output wave form	Modified sine wave						
20	Cooling fan [auto fan]	Fan on temperature 41°C (±5°C)						±5°C
21	Insulation transformer tester (withstand voltage)	2KV~2.5KV						±0.5KV
22	Over load protection	input sensor	100A					PL cable type
		input fuse	40A(12EA)	40A(8EA)	40A(4EA)	40A(8EA)	40A(4EA)	Car fuse type
		output sensor	50A(Sensor)					Terminal type
		output circuit breaker	60AH(DCP-BH)	75AH(DCP-BH)		35AH(DCP-PR)		SS-001 DCP-BH(PR)
		AC outlet/terminal	2P Outlet 15A / 3P-(2C)50A Terminal		1P Outlet 30A / 3P-30A Terminal			Output socket terminal
23	Dimensions (DxHxW)	Inch	8.85x6.06x16.53	8.85x6.06x21.26	8.85x6.06x18.50			
		mm	225x154x420	225x154x540	225x154x470			
	Weight	lb	16.76lb	22.05lb	18.74lb		±0.44lb	
		kg	7.6Kg	10.0Kg	8.5Kg		±200g	

Product in use ♦Specially equipped vehicles ♦Construction Power ♦Generator replacement ♦Power Tools ♦Medium-term vehicle air-conditioning  
 ♦Solar Energy ♦Refrigerator ♦Hammer drill ♦Motor pump ♦TV/Monitor ♦Compressors/Cutters ♦Welder(5KW or more)  
 ♦Other electric products \* Based on the models, the use might be different from the device.

⇒ Specification of the product may change without notification for the improvement of performance. ⇐

● Input connection diagram

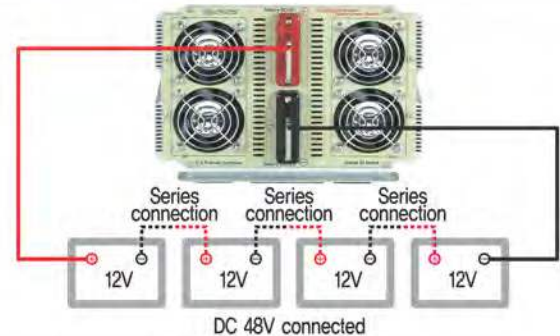
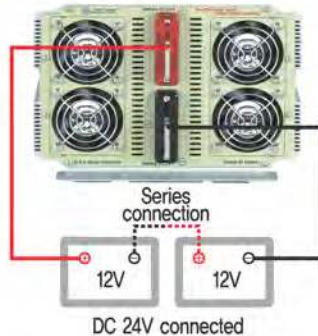
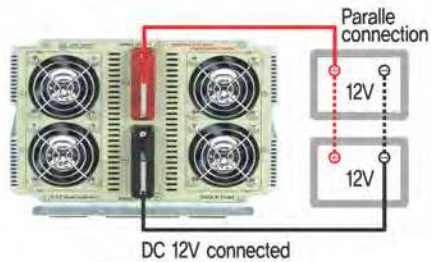

● Output connection diagram

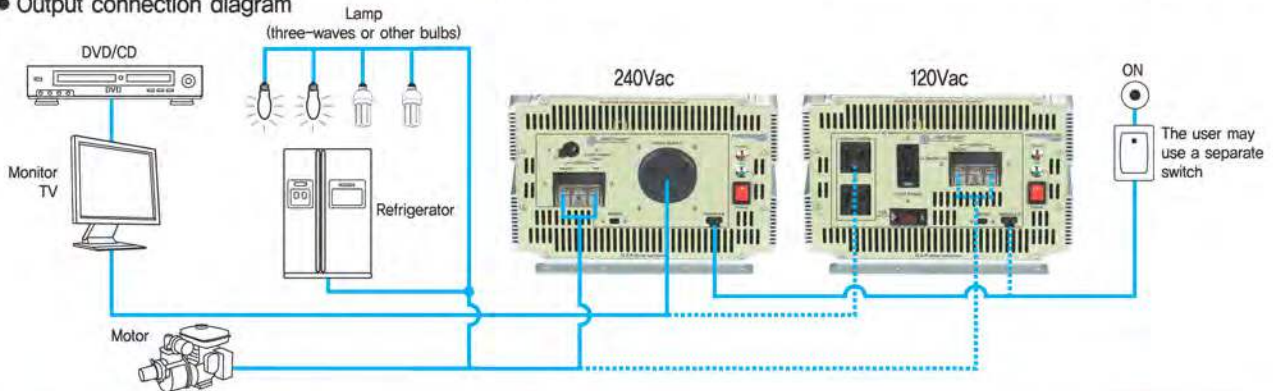

Avoid installing this inverter in a sealed area, or an area with poor ventilation/excessive heat



This product contains battery connections and sparks can easily occur. To prevent fire or other accidents, do not install this inverter in a small or partitioned area with flammable materials. Wet or moist environments are fatal to this inverter. Special care shall be taken, keep inverter out of direct sunlight.

240Vac Model

- PWRIG700024024(DC24V)
- PWRIG700024048(DC48V)

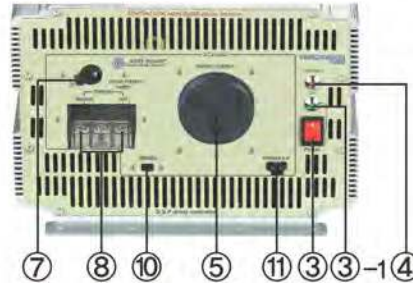

120Vac Model

- PWRIG500012W(DC12V)
- PWRIG700024W(DC24V)
- PWRIG700048W(DC48V)

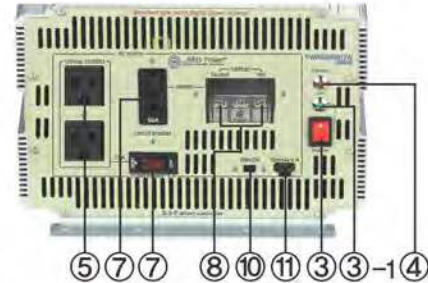

Use the function description

1. DC input power ⊕ red terminal 12V/24V/48V

12V/24V/48V DC input power ⊕ terminal. Connect the red cable to the terminal. Refer to the connection diagrams in the attached paper and according to order, connect the cables. Check ⊕ red polarity and secure connection. This terminal should be clamped tightly to work without failure because this terminal generate high current and overheat.

※Even slight loosening between bolts and nuts in the terminal and the cable will generate heat and make a play, which leads to failure of the product or dramatically drains battery life.

1-1. Input power fuse inside the product

An internal input fuse is located at ⊕ red wiring. It is for the safety reasons. Be careful when changing shorted fuses.

※As for the double layer model, loosen the screw from both panels and lift the upper panel lightly, and you can change a fuse.

※When you need to change fuses, consult an expert.

2. DC input power ⊖ black terminal 12V/24V/48V

12V/24V/48V DC input power ⊖ connection terminal. Connect the black cable to the terminal. Refer to the connection diagrams in the attached paper and according to order, connect the cables. Check ⊕ red polarity and secure connection. This terminal should be clamped securely to work without failure because this connection terminal generate high current and overheat

※Even slightly loosening between bolts and nuts in the terminal and the cable will generate heat and make a play, which leads to failure of the product or dramatically drains battery life.

### 3. Power switch

In the control circuit, DC input and AC output switches start simultaneously. The Power Switch turns the product on/off. Switch off when not in use.

※This switch is the only power switch on the inverter.

### 3-1. Power LED

This LED always light up when the power switch is on or this inverter is in operation.

### 4. Warning LED

Overheating or exceeding maximum capacity will shut down the product to protect and operation will be restored when the state is stabled and normalized. Before the shutdown, buzz noise will warn you. When you hear the sound, turn off the power switch, and then 3 or 4 minute later, turn on the switch back. If the product works properly, it is in normal condition. If the product sounds alarm, sent the product to our company's warranty service center to check.

※Functions of warning lamp (red LED)

A. Low battery    B. High battery    C. Over temperature protection    D. Over load LED    E. Surge protection    F. Output short light

As for the warning LED operation to stop each function, refer to cautions on the page 7.

### 5. 120Vac/240Vac 60hz/50hz power outlet

It is 120Vac/240Vac AC power outlet. It can be connected to devices needed 15A to 30A (according to models), and 4500W or less.

※Capacity (current) on the product greater than the indicated one will deform the outlet.

### 6. Automatic fan operation

When the internal temperature increases (40 to 48°C), ventilation automatically starts until cooling down to under 40°C. The direction of ventilation could be different according to model.

### 7. Output protection switch (circuit breaker switch)

Dramatic change and overload on output power outlet or terminal make the circuit breaker cause shutdown. When you turn the switch on under normal condition of input power, the output is turned off again. Check if it is overpower or failure.

### 8. Output power terminal

The outlet use around 4kw output. Devices using over 4kw such as a welder or a motor compressor should not use this terminal (3pin). Consult an expert for wiring.

※For the connection to this terminal (3pin), refer to the figure on the left.

※Neutral and common terminals share the same line on AC in the circuit.

※Caution : Don't connect to the earth terminal.

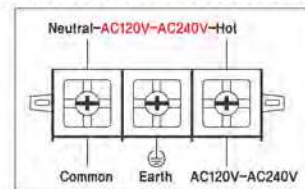

### 9. Ground terminal

The whole case is grounded. This can be used to ground other devices or equipment.

※3p terminal earth is the same with the ground terminal. You can use either of them.

### 10. Output frequency (60Hz ↔50Hz) select switch

※To change frequency, tune the switch to the frequency you want and turn it off. Wait until the power lamp light is completely out. Turn on the power. The product will work at the desired frequency.

### 11. Auxiliary power switch outlet (remote power switch connector)

If you want to turn the power switch on/off more than 1m to 2m away from the product, or if you have difficulty in using the switch in the spot where the product was installed, use the included wiring to connect another power switch. The auxiliary power switch can be used only when the power of the product is turned off.

### Check below items before repair report

Problems	Possible causes and check points	Solution
1. Low output voltage ; red LED lit	The device connected to the inverter uses exceeding capacity of the output and causes overload. (Check if it is overload)	<ul style="list-style-type: none"> <li>• Stop the device connected to the inverter.</li> <li>• To check the capacity of the inverter and use less than the capacity</li> </ul>
2. No output voltage even when connected to small power devices	To check charging status To check battery life span To check the cable	<ul style="list-style-type: none"> <li>• To check battery charging</li> <li>• To check the cable gauge</li> </ul>
3. Red LED lit and overload buzzer	To check the device connected to the inverter output. To check consumption power of the device.	<ul style="list-style-type: none"> <li>• To check the quality of the device connected to the inverter.</li> <li>• Motors or freezers should be operated within 50% of the maximum power marked on this inverter</li> </ul>
4. Input fuse open and circuit breaker shut down and sensor shutdown	To check wiring To check the device connected to the inverter	<ul style="list-style-type: none"> <li>• To check polarity of input wire.</li> <li>• To check the power input of the device connected to the inverter</li> </ul>
5. High output voltage dramatically increases output	To check if the battery is 12V or 24V or 48V	<ul style="list-style-type: none"> <li>• Use DVM to check battery voltage.</li> </ul>

### General problem

Noise from audio systems: general audio system or related equipment can generate noise signals when the inverter is in operation. It is caused by current at the device interference with the one through the inverter.

TV interference : operation of the power inverter can interfere with television reception on some channels.

- Audio equipment, TV, RF transmitter, should be installed 1.5m away from the inverter.
- Check your system is grounded well at the inverter ground terminal.

## Warranty

If the inverter still does not function correctly after troubleshooting, Please contact AIMS power tech support at [Techsupport@aimscorp.net](mailto:Techsupport@aimscorp.net) (775) 359-6703 ex227

For additional products such as :

- Modified sine wave inverters
- Low frequency pure sine wave inverters
- Pure sine wave inverters
- Solar charge controllers
- Grid-tie inverters
- Inverter chargers
- Automatic transfer switches
- Customer sized cables
- Batteries
- Solar panels



AIMS Operating Corp. Inc. Aims Power warranty instructions.

This product is designed and is under very strict quality control and testing guidelines. If however you feel this product is not performing as it should, please contact us: [Techsupport@aimscorp.net](mailto:Techsupport@aimscorp.net) or (775) 359-6703 ex227.

We will do our best to resolve any of your concerns. If the product needs repair or replacement make sure to keep your receipt/invoice, as that will need to be sent back along with the package and RMA# to AIMS Power. You have a full 1 year warranty from the date of purchase. This warranty is valid world-wide with the exception that freight and duty charges incurred outside the continuous 48 States. User is responsible for return shipping. Except as provided above, AIMS makes no warranty of any kind, express or implied, including without limitation the implied warranties of merchantability and fitness for a particular purpose. In no event shall AIMS be liable for indirect, special or consequential damages. This warranty only applies to AIMS Power branded products. All other name brand products are warranted by and according to their respective manufacturer. Please do not attempt to return non-AIMS Power branded products to AIMS Power.