

REVISIONS					
REV	ECO	DESCRIPTION	DATE	BY	APPR
A1	-	FIRST RELEASE	Jun.27,2015	Drack	Tommy
A2	-	UPDATE THE SHAPE	APR.18,2016	Drack	Tommy

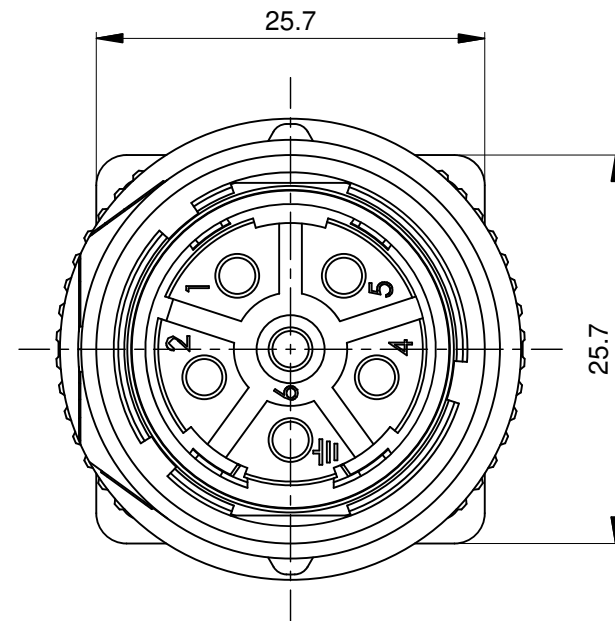

NOTES: UNLESS OTHERWISE SPECIFIED

- MATERIAL:
 - INSULATION INSERT: PA66,UL94 V0
 - SEAL: VITON
 - HOUSING BODY: ZINC DIE CAST, NICKEL PLATED
 - COUPLING NUT: ZINC DIE CAST, NICKEL PLATED
- SPECIFICATIONS:
 - 2.1 CURRENT RATING: 28 AMPS
 - 2.2 VOLTAGE RATING: 630V AC/DC
 - 2.3 OPERATING TEMPERATURE: -20°C TO +130°C
 - 2.4 DIELECTRIC WITHSTANDING VOLTAGE: LESS THAN 2 MILLIAMPS CURRENT LEAKAGE @ 6000 VOLTS AC.
 - 2.5 DEGREE OF PROTECTION: IP67 (MATED CONDITION)
 - 2.6 DEGREE OF POLLUTION: 3 PER UL840
 - 2.7 OVERVOLTAGE CATEGORY: III PER UL840
 - 2.8 MATING CYCLE DURABILITY: >500 CYCLES
 - 2.9 RoHS COMPLIANT
- ALL DIMENSIONS ARE FOR REFERENCE USE ONLY.

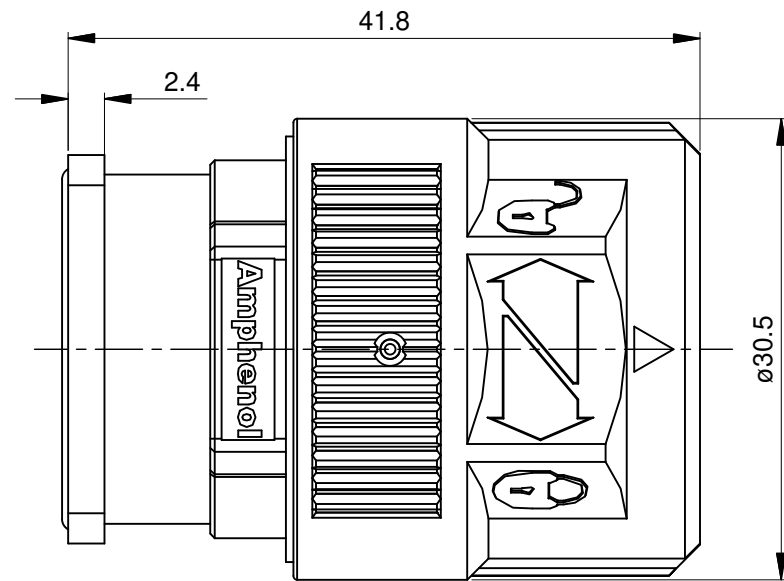
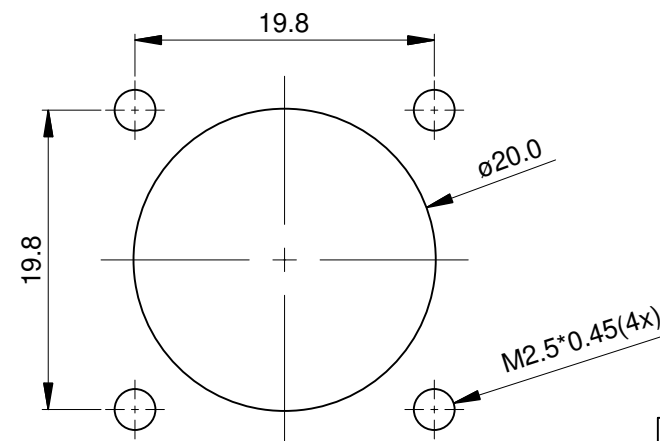
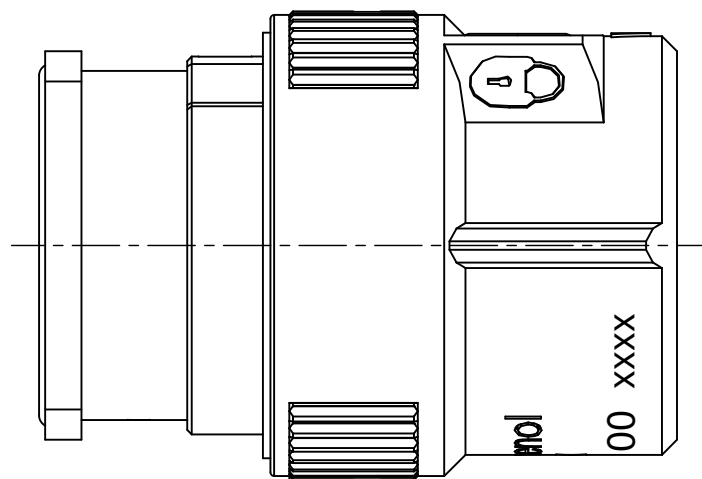

MOUNTING HOLE

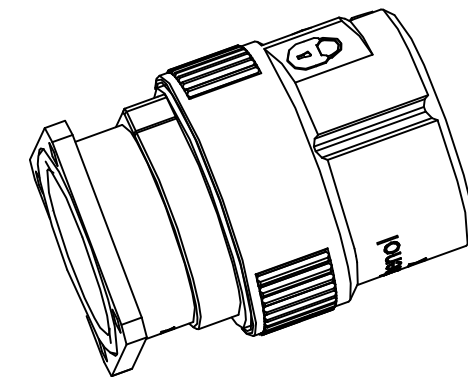

QUANTITY	SEE PART NUMBER PART NUMBER	DESCRIPTION	ITEM
MATERIALS LIST			
UNLESS OTHERWISE SPECIFIED 1) All dimensions are in metric (mm). 2) Tolerances are as follows: 1 PL DEC ±0.30 2 PL DEC ±0.15 3 PL DEC ±0.08 Fractions ±1/64 Angles ±1° 3) Note reference =		SIGNATURES DRAWN: Drack CHECKED: ENGINEER: APPROVAL: DATE: APR.18,2016	Amphenol Sine Systems - www.amphenol-sine.com 44724 Morley Drive Clinton Township, MI 48036
MATERIAL SPECIFICATIONS:		CUSTOMER:	M23B,PLUG,STR,6POS,FLANGE,CHECKMATE
PROCESS SPECIFICATIONS:		THIS DRAWING IS SUPPLIED FOR INFORMATION ONLY. DESIGN FEATURES, SPECIFICATIONS AND PERFORMANCE DATA SHOWN HEREON ARE THE PROPERTY OF THE AMPHENOL CORPORATION. NO RIGHTS OF REPRODUCTION ARE IMPLIED. ALL DIMENSIONS ARE SUBJECT TO NORMAL MANUFACTURING VARIATIONS.	SIZE: B C- DWG NO: MB2GJN0600 REVISION: A2
NEXT ASSY:		SCALE: NONE	SHEET 1 OF 1

TITLE: M23B,PLUG,STR,6POS,FLANGE,CHECKMATE
 DWG NO: MB2GJN0600
 REV: A2
 SH: 1
 OF: 1