

NOTES :

- 1- MATERIAL:**
- HOUSING: POLYESTER FIBER GLASS FILLED UL 94-V0, COLOR BLACK.
 - TERMINAL: PHOSPHOR BRONZE .
- PLATING 2:**
- POST PLATE (0.00127)/.000050 MIN GOLD IN CONTACT AREA
 - (0.00190)/.000075 MIN PURE TIN IN TAIL AREA
 - BOTH OVER (0.00127)/.000050 MIN NICKEL OVERALL.
- PLATING 7:**
- POST PLATE (0.00005)/.000002 MIN GOLD OVER (0.00076)/.000030 MIN
 - PALLADIUM NICKEL IN CONTACT AREA (0.00190)/.000075 MIN
 - PURE TIN IN TAIL AREA BOTH OVER (0.00127)/.000050 MIN NICKEL OVERALL (4 CKTS VERSION)

- 2- JACK FOR MATING WITH F.C.C. 68 PLUGS 90075 MOLEX SERIES.
- 3- PRODUCT SPECIFICATION PS-9500I.
- 4- APPLICATION SPECIFICATION AS-9500I.
- 5- PACKAGING SPECIFICATION PK-9500I; STANDARD PACKAGING SHEET 1. SPECIAL PACKAGING SHEET 2. TUBE PACKAGING SHEET 3.

EC NO: MG2005-0106 DRWN: MARTIN 2004/10/12 CHKD: FCARABET 2004/10/12 APPR: KNOLLER 2004/10/13	QUALITY SYMBOLS ▽=0 ▽=0	GENERAL TOLERANCES (UNLESS SPECIFIED)		DIMENSION STYLE MM/IN		SCALE 4:1	DESIGN UNITS METRIC	THIRD ANGLE PROJECTION	
		4 PLACES ± --- ± --- 3 PLACES ± --- ± .006 2 PLACES ± 0.15 ± .010 1 PLACE ± 0.25 ± --- ANGULAR ± ---°	DRAWN BY FB DATE 1993/02/24	TITLE R/A LOW PROFILE PC JACK 4,6,8 CKTS SIZE THROUGH HOLE VERSION		MOLEX INCORPORATED		DOCUMENT NO. SDA-95001	SHEET NO. 1 OF 9
DRAFT WHERE APPLICABLE MUST REMAIN WITHIN DIMENSIONS		SEE CHART SHEETS 4.5688		THIS DRAWING CONTAINS INFORMATION THAT IS PROPRIETARY TO MOLEX INCORPORATED AND SHOULD NOT BE USED WITHOUT WRITTEN PERMISSION					

TYPE \ DIM.	POS. 4		POS. 6		POS. 8	
	4 CKTS.	4 CKTS.	6 CKTS.	4 CKTS.	6 CKTS.	8 CKTS.
A	(11.18) / .440	(13.21) / .520	(13.21) / .520	(15.24) / .600	(15.24) / .600	(15.24) / .600
C $\pm 0.05 / \pm 0.002$	(7.62) / .300	(10.16) / .400	(10.16) / .400	(11.43) / .450	(11.43) / .450	(11.43) / .450
B $\pm 0.05 / \pm 0.002$	(3.81) / .150	(3.81) / .150	(6.35) / .250	(3.81) / .150	(6.35) / .250	(8.89) / .350

P.C.B. MOUNTING PATTERNS - SEE FROM COMPONENT SIDE

FOR SMT JACK TYPE (SURFACE MOUNT)

FOR STANDARD JACK TYPE (THROUGH HOLE)

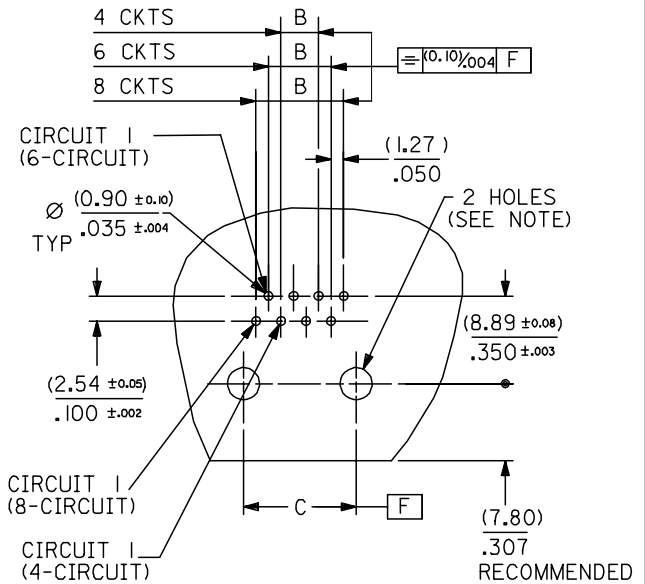
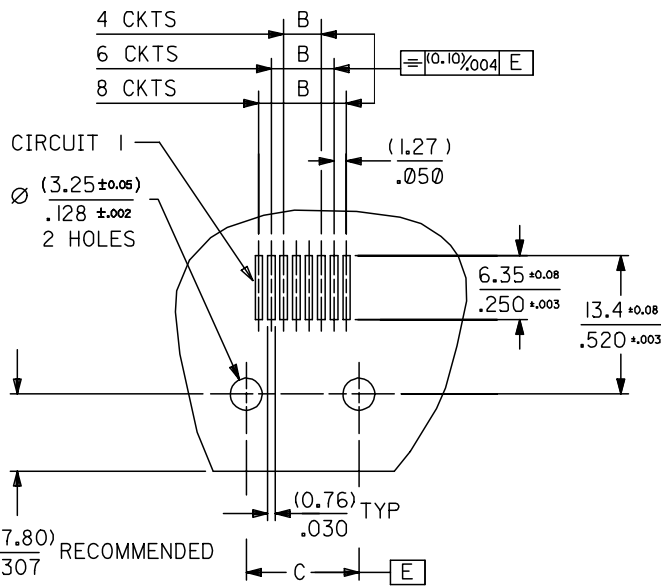

FOR ALL VERSIONS, CIRCUIT 1 ALWAYS ON THE LEFT SIDE

NOTE:
FOR CONVECTION SOLDERING: DIA 3.25 \pm 0.05 / .128 \pm .002
FOR WAVE SOLDERING: DIA 3.20 \pm 0.10 / .126 \pm .004

EC NO: MG2005-0106 DRAWN: MARTIN 2004/10/12 CHKD: FCARABET 2004/10/12 APPR: KNOLLER 2004/10/13	QUALITY SYMBOLS ▽=0 ▽=0	GENERAL TOLERANCES (UNLESS SPECIFIED)		DIMENSION STYLE MM/IN		SCALE 2:1	DESIGN UNITS METRIC	THIRD ANGLE PROJECTION	
		4 PLACES \pm --- \pm --- 3 PLACES \pm --- \pm .006 2 PLACES \pm 0.15 \pm .010 1 PLACE \pm 0.25 \pm --- ANGULAR \pm ---°	mm INCH FB 2004/09/25 DATE DATE DATE	TITLE R/A LOW PROFILE JACK PC JACK 4,6,8 CKT SIZE SMT AND STANDARD VERSION		MOLEX INCORPORATED		DOCUMENT NO. SDA-95001	
DRAFT WHERE APPLICABLE MUST REMAIN WITHIN DIMENSIONS		MATERIAL NO. SEE CHART SHEETS 4,5&6		THIS DRAWING CONTAINS INFORMATION THAT IS PROPRIETARY TO MOLEX INCORPORATED AND SHOULD NOT BE USED WITHOUT WRITTEN PERMISSION					

STANDARD PACKAGING OPEN TRAY ,SEE PACKAGING SPEC PK95001 SHEET 1

PART NO FOR JACK ASSEMBLY

STANDARD VERSION

SPECIAL VERSION
HIGH TEMPERATURE

HOUSING SIZE	LOADED CONTACTS	PLATING	POLYESTER FIBER GLASS FILED 94V0,COLOR BLACK.						POLYAMIDE FIBER GLASS FILLED COLOR BLACK				
			NO KEY		KEY		TOOLED	TOOLED	NO KEY		KEY		
			NOT RIBBED	TOOLED	NOT RIBBED	TOOLED			NOT RIBBED	TOOLED	NOT RIBBED	TOOLED	
4	4	2	9500I-244I	X	9500I-2442					9500I-844I	X		
6	4	2	9500I-264I	X	9500I-2642					9500I-864I	X		
6	6	2	9500I-266I	X	9500I-2662					9500I-866I	X		
8	4	2	9500I-284I		9500I-2842								
8	6	2	9500I-286I	X	9500I-2862								
8	8	2	9500I-288I	X	9500I-2882	X				9500I-888I	X		

EC NO: MG2005-0106 DRAWN: MARTIN 2004/10/12 CHKD: FCARABET 2004/10/12 APPR: KNOLLER 2004/10/13	QUALITY SYMBOLS	GENERAL TOLERANCES (UNLESS SPECIFIED)		DIMENSION STYLE MM ONLY		SCALE ---	DESIGN UNITS METRIC	THIRD ANGLE PROJECTION		
	▽=0 ▽=0	4 PLACES	±---	±---	mm	INCH	DRAWN BY DP	DATE 1989/06/01	TITLE LOW PROFILE R/A JACK STANDARD AND SMT VERSION STANDARD OPEN TRAY VERS	
		3 PLACES	±---	±---			CHECKED BY FB	DATE 1989/06/01	MOLEX INCORPORATED	
		2 PLACES	±---	±---			APPROVED BY JB	DATE 1989/06/01	DOCUMENT NO. SDA-95001	
		1 PLACE	±---	±---			MATERIAL NO.		SHEET NO. 4 OF 9	
		ANGULAR ±---°		DRAFT WHERE APPLICABLE MUST REMAIN WITHIN DIMENSIONS		SEE CHART				
				SIZE A3		THIS DRAWING CONTAINS INFORMATION THAT IS PROPRIETARY TO MOLEX INCORPORATED AND SHOULD NOT BE USED WITHOUT WRITTEN PERMISSION				