

FCI CONFIDENTIAL



FCIconnect.com

This document is the property of and embodies CONFIDENTIAL and PROPRIETARY information of FCI. No part of the information shown on this document may be used in any way or disclosed to others without the written consent of FCI. Copyright FCI.

PRODUCT NO.
92140

PRODUCT NO.	STAND OFF	SOLDER TAIL	DIM "P" (mm)	DIM "Q" (mm)	FOR LOWER DECK OR UPPER DECK	HOLD DOWN	LOCATOR FOR SOLDER TAIL ALIGNMENT	SHEET NO.	MOUNTING STYLE TO PCB
92140-XXXX	0	R/A	2.8	---	LOWER	NONE	NONE	NO.2	TOP MOUNT 92140-XXXX
000	0	R/A	2.8	---	LOWER	NONE	NONE		
000M	0	R/A	2.8	---	LOWER	NONE	NONE		
000LF	0	R/A	2.8	---	LOWER	NONE	NONE		
000MLF	0	R/A	2.8	---	LOWER	NONE	NONE		
000H	0	R/A	2.8	---	LOWER	YES	NONE		
000HLF	0	R/A	2.8	---	LOWER	YES	NONE		
001	0	SMT STG.	---	---	LOWER	NONE	NONE		
001LF	0	SMT STG.	---	---	LOWER	NONE	NONE		
001H	0	SMT STG.	---	---	LOWER	YES	NONE		
001HLF	0	SMT STG.	---	---	LOWER	YES	NONE		
002	0	SMT L.L.	---	---	LOWER	NONE	NONE		
002LF	0	SMT L.L.	---	---	LOWER	NONE	NONE		
002H	0	SMT L.L.	---	---	LOWER	YES	NONE		
002HLF	0	SMT L.L.	---	---	LOWER	YES	NONE		
010	4	R/A	2.8	---	LOWER	NONE	YES		
010LF	4	R/A	2.8	---	LOWER	NONE	YES		
010H	4	R/A	2.8	---	LOWER	YES	YES		
010HLF	4	R/A	2.8	---	LOWER	YES	YES		
020	5	R/A	2.8	---	LOWER	NONE	YES		
020LF	5	R/A	2.8	---	LOWER	NONE	YES		
020MLF	5	R/A	2.8	---	LOWER	NONE	YES		
021MLF	5	R/A	2.8	---	LOWER	NONE	YES		
020H	5	R/A	2.8	---	LOWER	YES	YES		
020HLF	5	R/A	2.8	---	LOWER	YES	YES		
026HLF	5	R/A	2.8	---	LOWER	YES	YES		
040	2	R/A	2.5	---	LOWER	NONE	NONE		
040LF	2	R/A	2.5	---	LOWER	NONE	NONE		
040HLF	2	R/A	2.5	---	LOWER	YES	NONE		
050	3	R/A	2.8	---	LOWER	NONE	YES		
050LF	3	R/A	2.8	---	LOWER	NONE	YES		
050H	3	R/A	2.8	---	LOWER	YES	YES		
050HLF	3	R/A	2.8	---	LOWER	YES	YES		
005	FOR 0	R/A	2.8	8.6	UPPER	NONE	YES		
005LF	FOR 0	R/A	2.8	8.6	UPPER	NONE	YES		
045	FOR 2	R/A	2.5	10.3	UPPER	NONE	YES		
045LF	FOR 2	R/A	2.5	10.3	UPPER	NONE	YES		
500	0	R/A	2.8	---	LOWER	NONE	NONE		
500LF	0	R/A	2.8	---	LOWER	NONE	NONE		
500H	0	R/A	2.8	---	LOWER	YES	NONE		
500HLF	0	R/A	2.8	---	LOWER	YES	NONE		
501	0	SMT STG.	---	---	LOWER	NONE	NONE		
501LF	0	SMT STG.	---	---	LOWER	NONE	NONE		
501H	0	SMT STG.	---	---	LOWER	YES	NONE		
501HLF	0	SMT STG.	---	---	LOWER	YES	NONE		
502	0	SMT L.L.	---	---	LOWER	NONE	NONE		
502LF	0	SMT L.L.	---	---	LOWER	NONE	NONE		
502H	0	SMT L.L.	---	---	LOWER	YES	NONE		
502HLF	0	SMT L.L.	---	---	LOWER	YES	NONE		
503	0	SMT L.L.	---	---	LOWER	NONE	NONE		
503LF	0	SMT L.L.	---	---	LOWER	NONE	NONE		
510	4	R/A	2.8	---	LOWER	NONE	YES		
510LF	4	R/A	2.8	---	LOWER	NONE	YES		
510HLF	4	R/A	2.8	---	LOWER	YES	YES		
520	5	R/A	2.8	---	LOWER	NONE	YES		
520LF	5	R/A	2.8	---	LOWER	NONE	YES		
520H	5	R/A	2.8	---	LOWER	YES	YES		
520HLF	5	R/A	2.8	---	LOWER	YES	YES		
530	2	R/A	1.48	---	LOWER	NONE	NONE		
530LF	2	R/A	1.48	---	LOWER	NONE	NONE		
540	2	R/A	2.5	---	LOWER	NONE	NONE		
540LF	2	R/A	2.5	---	LOWER	NONE	NONE		
505	FOR 0	R/A	2.8	8.6	UPPER	NONE	YES		
505LF	FOR 0	R/A	2.8	8.6	UPPER	NONE	YES		
535	FOR 2	R/A	1.48	9.28	UPPER	NONE	YES		
535LF	FOR 2	R/A	1.48	9.28	UPPER	NONE	YES		
545	FOR 2	R/A	2.5	10.3	UPPER	NONE	YES		
545LF	FOR 2	R/A	2.5	10.3	UPPER	NONE	YES		

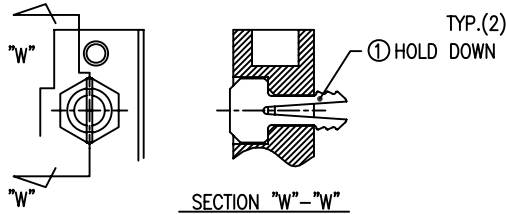
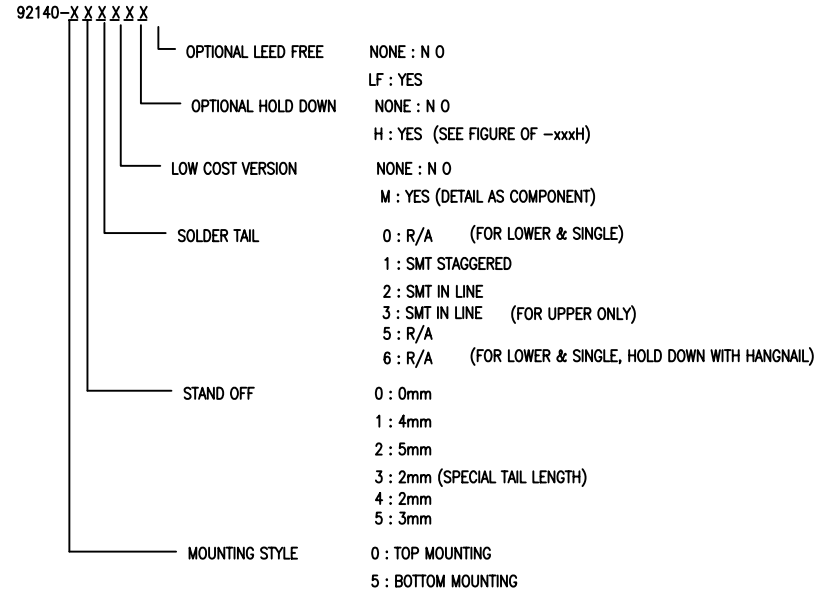

92140-xxxH
(OPTIONAL HOLD DOWN)

NOTE
1. THIS PRODUCT MEETS EUROPEAN UNION DIRECTIVES AND OTHER COUNTRY REGULATIONS AS DESCRIBED IN GS-22-008.
2. PRODUCT SPEC: 110-263

mat'l. code		surface		tolerance		projection		product family	
		ISO 1902		ISO 406 ISO 1101				PCMCIA	
ltr		ecn no		date		tolerances unless otherwise specified		title	
AL		ELX-N-011428		ZK 04/23/12		angles		68 POS EJECTOR HEADER ASSY	
AM		ELX-N-16398		JH 11/28/13		linear		FOR 5.0V APPLICATION	
						±2°		scale	
		dr		Mike Zhou		11/21/06		dwg no	
AH		N08-0219		MZ 11/14/08		enrg		Mike Zhou 11/21/06	
AJ		N09-0045		SH 05/26/09		chr		David Qin 11/21/06	
AK		ELX-N-007949		ZK 11/01/11		appd		Jack Wang 11/21/06	
sheet		revision		AM				sheet 1 of 7	
index		sheet		1-7				size A4	
								type CUSTOMER Drawing	

PRODUCT NO.
92140-000M
92140-000MLF
92140-000H
92140-000HLF
92140-001
92140-001LF
92140-001H
92140-001HLF
92140-002
92140-002LF
92140-002H
92140-002HLF

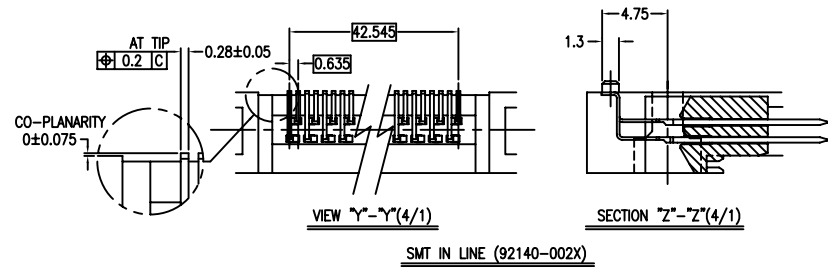
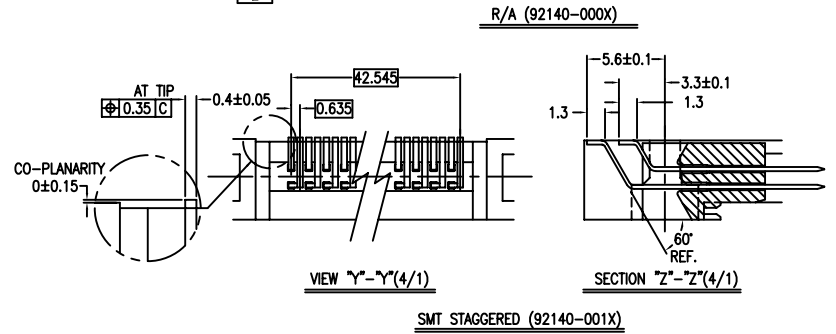
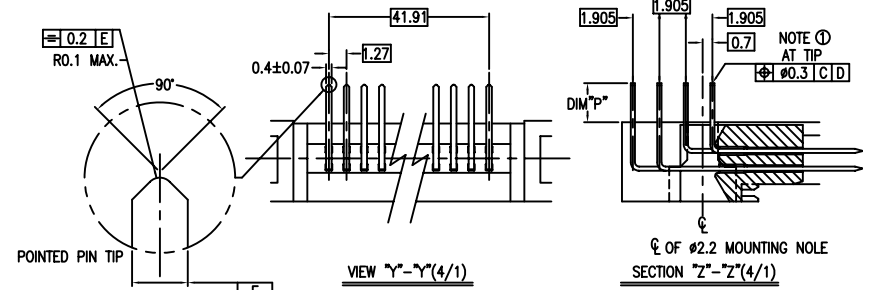
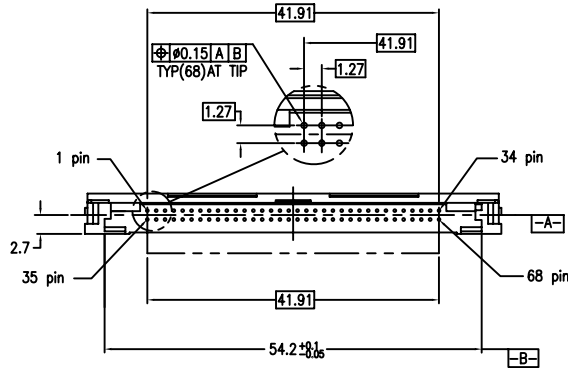
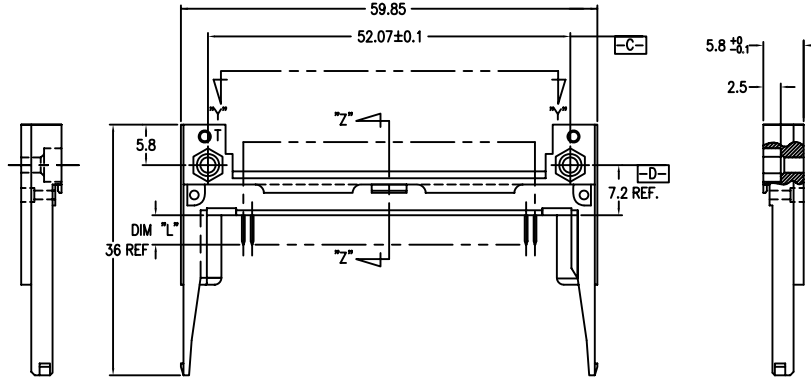

- NOTES
- TRUE POSITION IS A FREE GRID TO PIN PATTERN ITSELF.
 - SEE TA-946 FOR PCB LAYOUT.
 - MATERIAL HOUSING : HIGH TEMPERATURE THERMOPLASTIC UL94V-0 BLACK
PIN : COPPER ALLOY.
HOLD-DOWN : BRASS
 - FINISH PIN
UNDER PLATING : 0.5µm MIN. Ni.
CONTACT AREA : 0.076 µm MIN. GOLD

NOTE:SPECIAL VERSION:ONLY 0.25µm Au
SOLDER AREA : 2.5µm MIN. Sn-Pb.
OR 2.5µm MIN. PURE Sn.(FOR -XXXLF)
HOLD-DOWN : 2.5µm MIN. PURE Sn.

- RECOMMENDED PCB HOLE (OPTIONAL HOLD-DOWN) : 2.3±0.1
- SEQUENCE PIN ASSIGNMENT

		DIM "L"		
		4.25±0.1	3.5±0.1	5.0±0.1
PIN No.	OTHERS	36.67	117.34	35.51.88

- GENERAL TOLERANCE : ±0.3
- SEE SHEET 1 REGARDING COMPONENTS.

mat'l. code		surface		tolerance		projection		product family		PCMCIA	
ltr		ecn no		dr		date		title		88 POS EJECTOR HEADER ASSY FOR 5.0V APPLICATION	
AM				angles		linear		MM		dwg no	
				±2'		0.XX±0.13		scale		sheet 2 of 7	
				dr		Mike Zhou		11/21/06		size	
				enr		Mike Zhou		11/21/06		A4	
				chr		David Qin		11/21/06		92140	
				appd		Jack Wang		11/21/06		type CUSTOMER Drawing	
sheet		revision									
index		sheet									

PRODUCT NO.	PRODUCT NO.
92140-010	92140-010LF
92140-010H	92140-010HLF
92140-020	92140-020LF
92140-020H	92140-020HLF
92140-040	92140-040LF
92140-050	92140-050LF
92140-050H	92140-050HLF
92140-020MLF	92140-040HLF
92140-021MLF	
92140-026HLF	

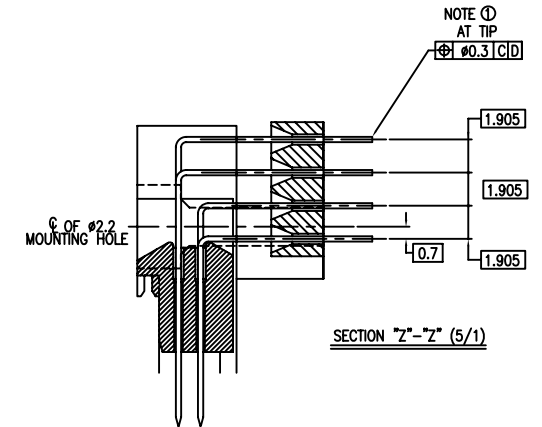
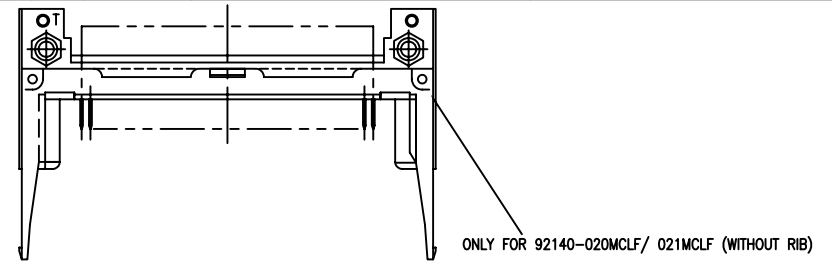
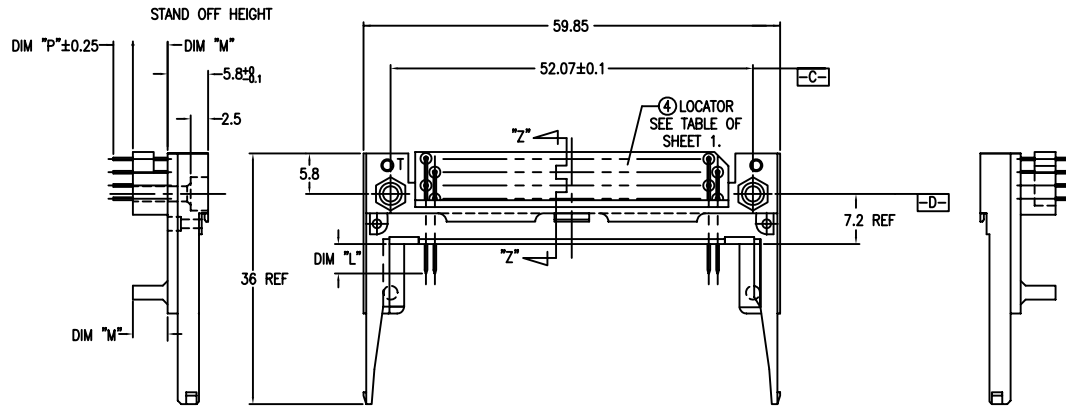

- NOTES
- TRUE POSITION IS A FREE GRID TO PIN PATTERN ITSELF.
 - SEE TA-946 FOR PCB LAYOUT.
 - MATERIAL
 - HOUSING : HIGH TEMPERATURE THERMOPLASTIC UL94V-0 BLACK
 - PIN : COPPER ALLOY
 - HOLD-DOWN : BRASS
 - FINISH PIN
 - UNDER PLATING : 0.5µm MIN. Ni.
 - CONTACT AREA 1 : 0.076 µm MIN. GOLD
 - CONTACT AREA 2 : 0.076 µm MIN. GOLD (FOR -XXXMLF).
 - SOLDER AREA : 2.5µm MIN. Sn-Pb.
 - OR 2.5µm MIN. PURE Sn.(FOR -XXXLF&XXXMLF)
 - HOLD-DOWN : 2.5µm MIN. PURE Sn.
 - RECOMMENDED PCB HOLE (OPTIONAL HOLD-DOWN) : 2.3±0.1
 - SEQUENCE PIN ASSIGNMENT
- | | DIM "L" | | |
|---------|----------|---------|---------|
| | 4.25±0.1 | 3.5±0.1 | 5.0±0.1 |
| PIN No. | OTHERS | 36.67 | 36.57 |
- GENERAL TOLERANCE : ±0.3
 - SEE SHEET 1 REGARDING COMPONENTS.
 - THIS PRODUCT MEETS EUROPEAN UNION DIRECTIVES AND OTHER COUNTRY REGULATIONS AS DESCRIBED IN GS-22-008

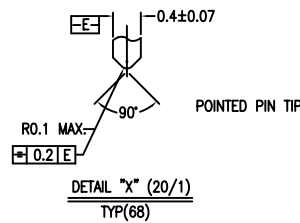
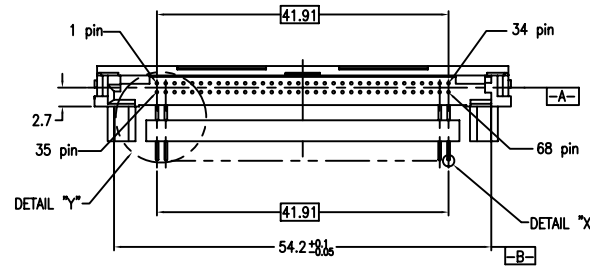
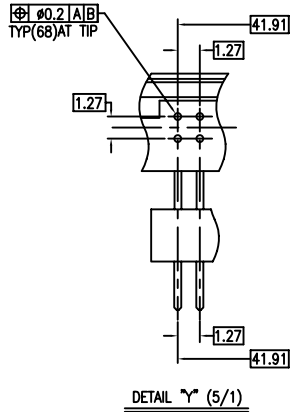

mat'l. code		surface	tolerance	projection	product family
		ISO 1302	ISO 406 ISO 1101		PCMCIA
ltr		ecn no	dr	date	title
AM					68 POS EJECTOR HEADER ASSY FOR 5.0V APPLICATION
		angles	linear	scale	dwg no
		±2'	0.X±0.3	MM	92140
			0.XX±0.13		sheet 3 of 7
			0.XXX±0.051		size
		dr	Mike Zhou	11/21/06	A4
		enfr	Mike Zhou	11/21/06	
		chr	David Qin	11/21/06	
		appd	Jack Wang	11/21/06	
sheet index		revision sheet			type CUSTOMER Drawing



FCIconnect.com

PRODUCT NO.
92140-005
92140-005LF
92140-045
92140-045LF

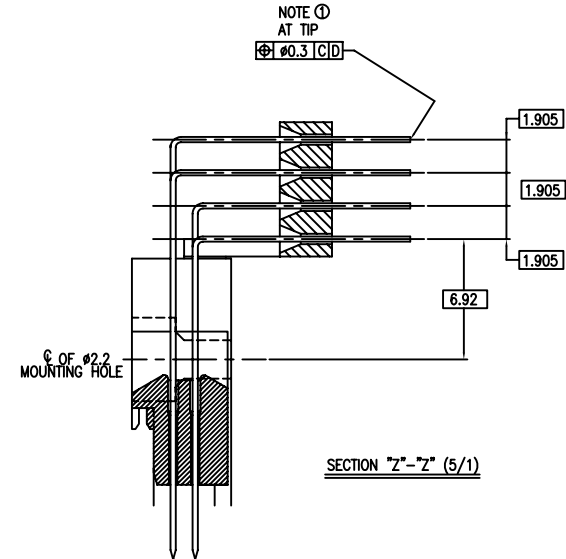
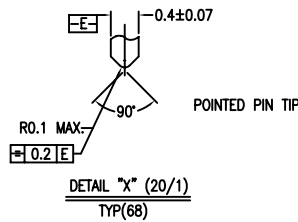
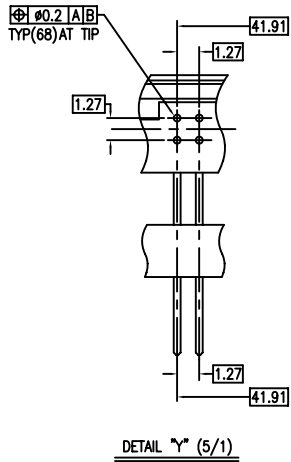
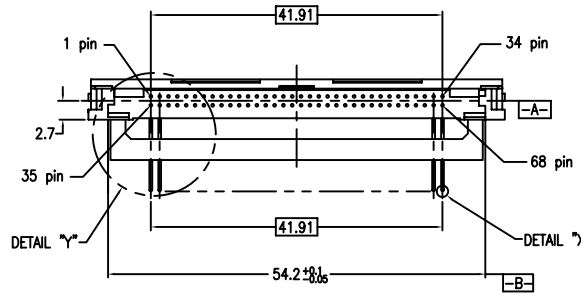
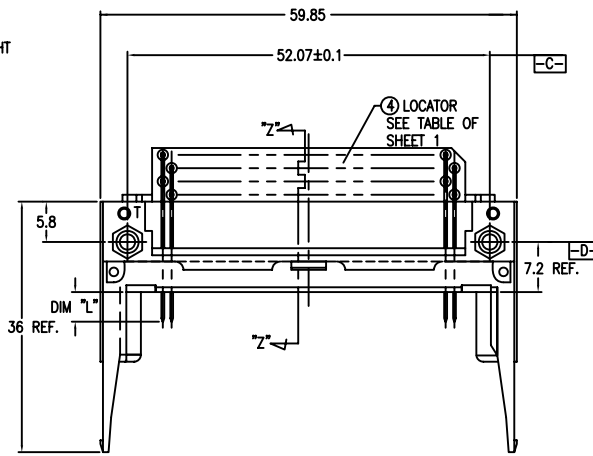
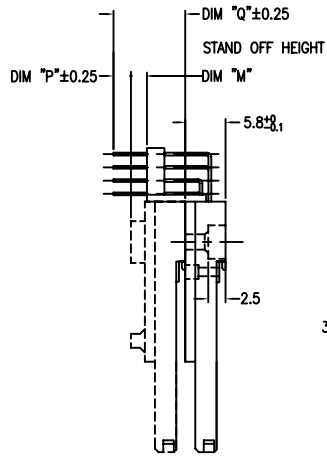

NOTES

- TRUE POSITION IS A FREE GRID TO PIN PATTERN ITSELF.
- SEE TA-946 FOR PCB LAYOUT.
- MATERIAL
HOUSING : HIGH TEMPERATURE THERMOPLASTIC UL94V-0 BLACK
PIN : COPPER ALLOY
HOLD-DOWN : BRASS
- FINISH
PIN
UNDER PLATING : 0.5µm MIN. Ni.
CONTACT AREA : 0.076 µm MIN. GOLD
SOLDER AREA : 2.5µm MIN. Sn-Pb.
OR 2.5µm MIN. PURE Sn.(FOR -XXLF)
HOLD-DOWN : 2.5µm MIN. PURE Sn.
- RECOMMENDED PCB HOLE (OPTIONAL HOLD-DOWN) : 2.3±0.1
- SEQUENCE PIN ASSIGNMENT

PIN No.	DIM "Z"		
	4.25±0.1	3.5±0.1	5.0±0.1
OTHERS	36.67	17.54	35.31/68

- GENERAL TOLERANCE : ±0.3
- SEE SHEET 1 REGARDING COMPONENTS.
- THIS PRODUCT MEETS EUROPEAN UNION DIRECTIVES AND OTHER COUNTRY REGULATIONS AS DESCRIBED IN GS-22-008

mat'l. code		surface		tolerance		projection		product family		PCMCIA	
		ISO 1302		ISO 406 ISO 1101		⊕					
ltr		ecn no		dr		date		tolerances unless otherwise specified		title	
AM								0.X±0.3		68 POS EJECTOR HEADER ASSY	
								0.XX±0.13		FOR 5.0V APPLICATION	
								0.XXX±0.051			
								MM		dwg no	
								scale		sheet 4 of 7	
								FCI		size	
										A4	
										type	
										CUSTOMER Drawing	
sheet		revision									
index		sheet									

PRODUCT NO.
92140-500
92140-500LF
92140-500H
92140-500HLF
92140-501
92140-501LF
92140-501H
92140-501HLF
92140-502
92140-502LF
92140-502H
92140-502HLF
92140-503
92140-503LF

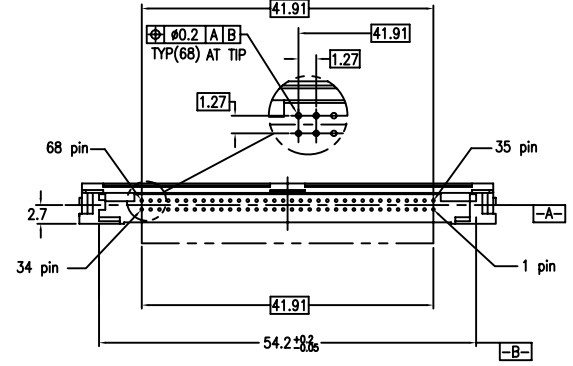
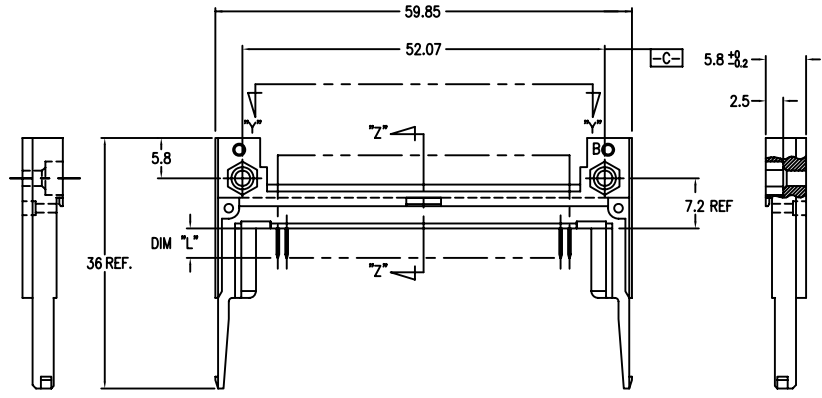

NOTES

- TRUE POSITION IS A FREE GRID TO PIN PATTERN ITSELF.
- SEE TA-946 FOR PCB LAYOUT.
- MATERIAL
HOUSING : HIGH TEMPERATURE THERMOPLASTIC UL94V-0 BLACK
PIN : PHOSPHOR BRONZE.
HOLD-DOWN : BRASS
- FINISH
PIN
UNDER PLATING : 0.5um MIN. Ni.
CONTACT AREA : 0.076 um MIN. GOLD
SOLDER AREA : 2.5um MIN. Sn-Pb.
OR 2.5um MIN. PURE Sn.(FOR -XXXLF)
HOLD-DOWN : 2.5um MIN. PURE Sn.
- RECOMMENDED PCB HOLE (OPTIONAL HOLD-DOWN) : 2.3±0.1
- SEQUENCE PIN ASSIGNMENT

	DIM "L"		
	4.25±0.1	3.5±0.1	5.0±0.1
PIN No.	OTHERS	36,67	35,51,68

- GENERAL TOLERANCE : ±0.3
- SEE SHEET 1 REGARDING COMPONENTS.
- THIS PRODUCT MEETS EUROPEAN UNION DIRECTIVES AND OTHER COUNTRY REGULATIONS AS DESCRIBED IN GS-22-008

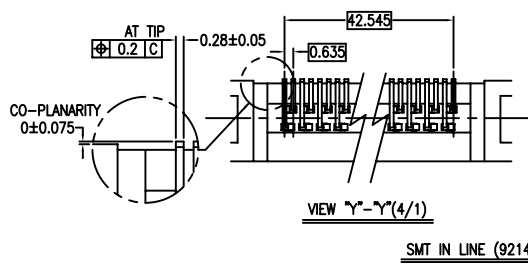
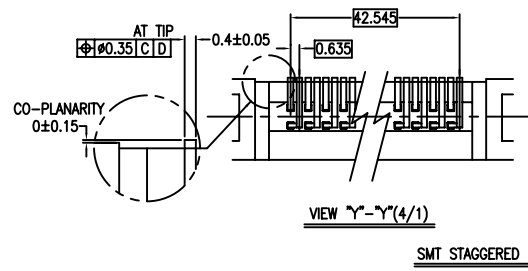
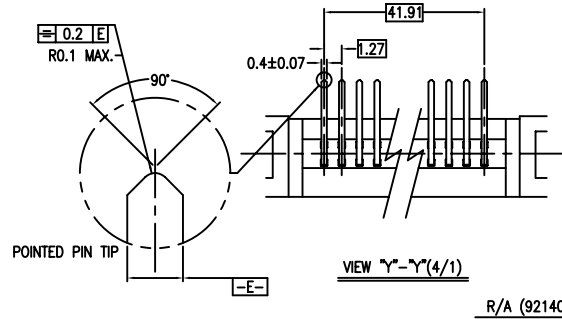

mat'l. code		surface		tolerance		projection		product family	
		ISO 1902		ISO 406 ISO 1101				PCMCIA	
ltr		ecn no		dr		date		title	
AM								68 POS EJECTOR HEADER ASSY FOR 5.0V APPLICATION	
		angles		linear				dwg no	
		±2°		0.X±0.3 0.XX±0.13 0.XXX±0.051		MM		sheet 5 of 7	
		dr		Mike Zhou		11/21/06		size	
		enr		Mike Zhou		11/21/06		A4	
		chr		David Qin		11/21/06		type	
		appd		Jack Wang		11/21/06		CUSTOMER Drawing	
sheet		revision							
index		sheet							

FCI CONFIDENTIAL



This document is the property of and embodies CONFIDENTIAL and PROPRIETARY information of FCI. No part of the information shown on this document may be used in any way or disclosed to others without the written consent of FCI.
Copyright FCI

PRODUCT NO.		
92140-510	92140-510LF	92140-510HLF
92140-520	92140-520LF	
92140-520H	92140-520HLF	
92140-530	92140-530LF	
92140-540	92140-540LF	

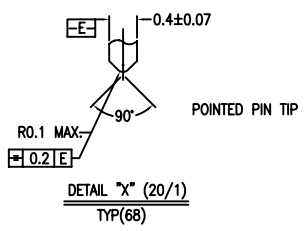
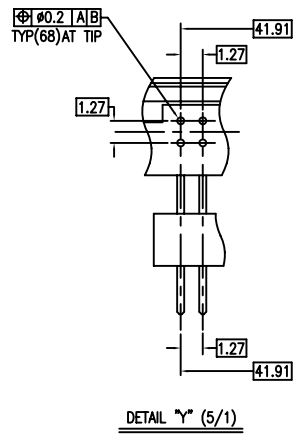
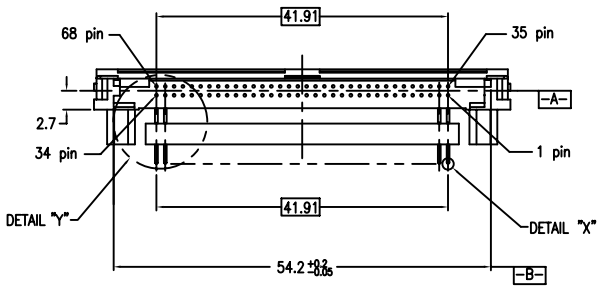
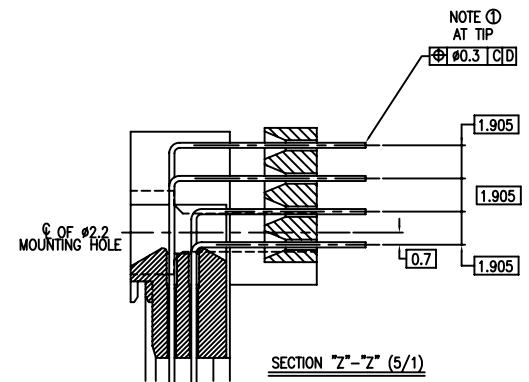
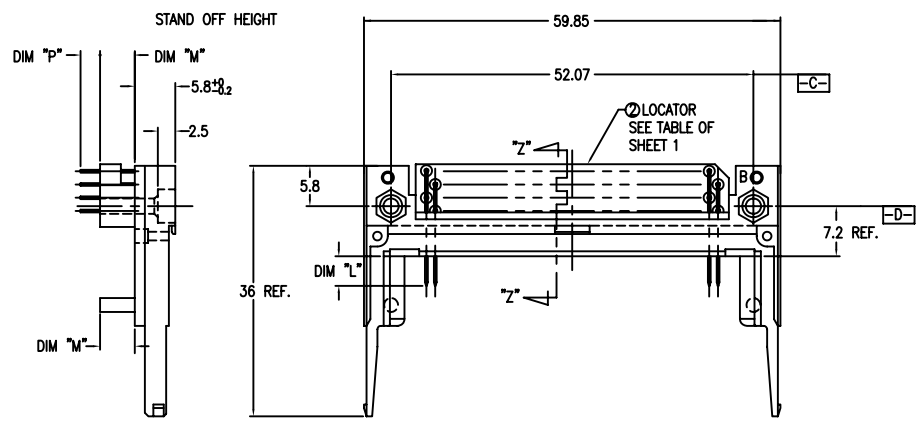

- NOTES
- TRUE POSITION IS A FREE GRID TO PIN PATTERN ITSELF.
 - SEE TA-946 FOR PCB LAYOUT.
 - MATERIAL
HOUSING : HIGH TEMPERATURE THERMOPLASTIC UL94V-0 BLACK
PIN : COPPER ALLOY.
HOLD-DOWN : BRASS
 - FINISH
PIN
UNDER PLATING : 0.5µm MIN. Ni.
CONTACT AREA : 0.076 µm MIN. GOLD
SOLDER AREA : 2.5µm MIN. Sn-Pb.
OR 2.5µm MIN. PURE Sn.(FOR -XXXLF)
HOLD-DOWN : 2.5µm MIN. PURE Sn.
 - RECOMMENDED PCB HOLE (OPTIONAL HOLD-DOWN) : 2.3±0.1
 - SEQUENCE PIN ASSIGNMENT

PIN No.	DIM "L"		
	4.25±0.1	3.5±0.1	5.0±0.1
OTHERS	36.67	35.51	36.88

- GENERAL TOLERANCE : ±0.3
- SEE SHEET 1 REGARDING COMPONENTS.
- THIS PRODUCT MEETS EUROPEAN UNION DIRECTIVES AND OTHER COUNTRY REGULATIONS AS DESCRIBED IN GS-22-008

mat'l. code		surface	tolerance	projection	product family	PCMCIA
ltr		ISO 1302	ISO 406 ISO 1101	101	title	
AM		angles	tolerances unless otherwise specified	MM	68 POS EJECTOR HEADER ASSY FOR 5.0V APPLICATION	
		±2°	0.X±0.3 0.XX±0.13 0.XXX±0.051	scale	dwg no 92140 sheet 6 of 7 size A4	
		dr	Mike Zhou	11/21/06	type CUSTOMER Drawing	
		enr	Mike Zhou	11/21/06		
		chr	David Qin	11/21/06		
		appd	Jack Wang	11/21/06		
sheet index	revision sheet					

FCI CONFIDENTIAL



This document is the property of and embodies CONFIDENTIAL and PROPRIETARY information of FCI. No part of the information shown on this document may be used in any way or disclosed to others without the written consent of FCI.
Copyright FCI

PRODUCT NO.
92140-505
92140-505LF
92140-535
92140-535LF
92140-545
92140-545LF

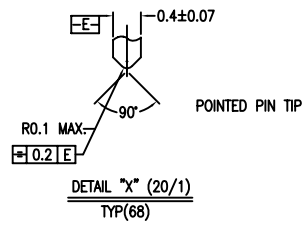
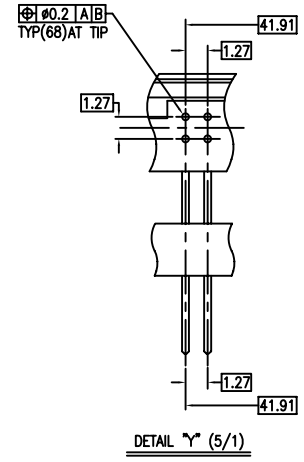
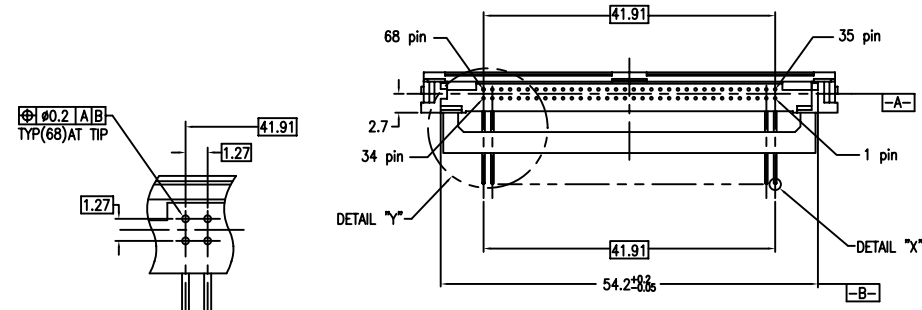
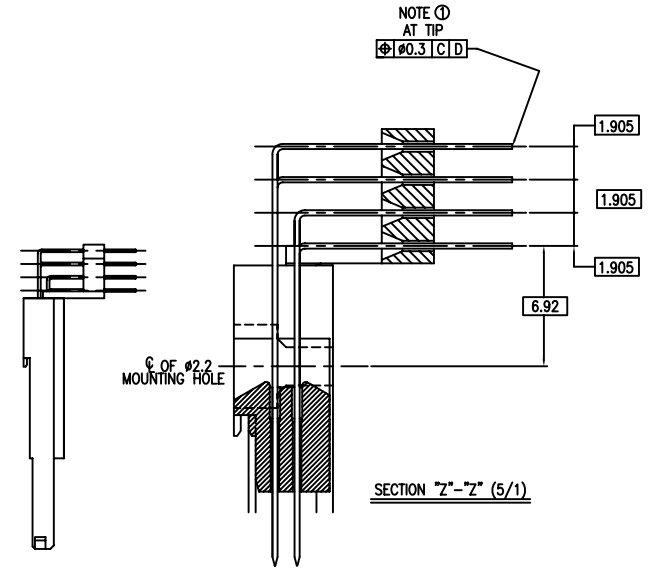
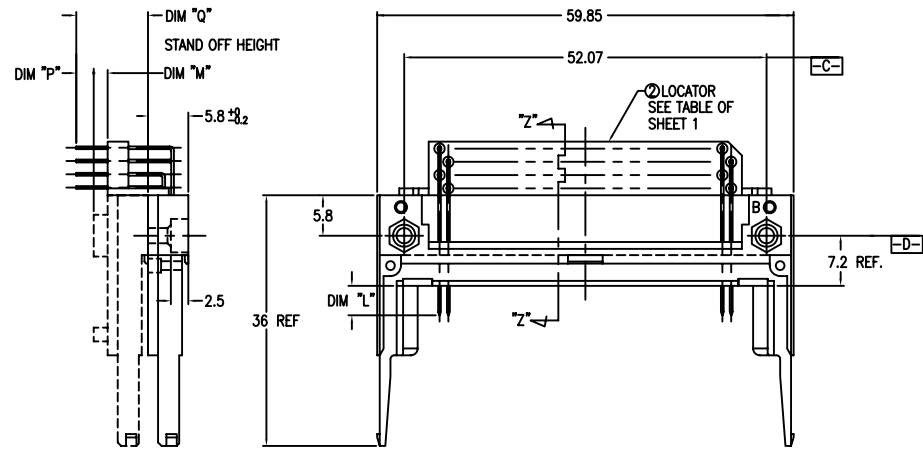

NOTES

- TRUE POSITION IS A FREE GRID TO PIN PATTERN ITSELF.
- SEE TA-946 FOR PCB LAYOUT.
- MATERIAL
HOUSING : HIGH TEMPERATURE THERMOPLASTIC UL94V-0 BLACK
PIN : COPPER ALLOY.
HOLD-DOWN : BRASS
- FINISH PIN
UNDER PLATING : 0.5µm MIN. Ni.
CONTACT AREA : 0.076 µm MIN. GOLD

SOLDER AREA : 2.5µm MIN. Sn-Pb.
OR 2.5µm MIN. PURE Sn.(FOR -XXXLF)
HOLD-DOWN : 2.5µm MIN. PURE Sn.
- RECOMMENDED PCB HOLE (OPTIONAL HOLD-DOWN) : 2.3±0.1
- SEQUENCE PIN ASSIGNMENT

PIN No.	DIM 'L'		
	4.25±0.1	3.5±0.1	5.0±0.1
OTHERS	36.67	1.1734	35.5788

- GENERAL TOLERANCE : ±0.3
- SEE SHEET 1 REGARDING COMPONENTS.
- THIS PRODUCT MEETS EUROPEAN UNION DIRECTIVES AND OTHER COUNTRY REGULATIONS AS DESCRIBED IN GS-22-008
- PRODUCT SPEC: 110-263

mat'l. code		surface		tolerance		projection		product family	
		ISO 1902		ISO 406 ISO 1101				PCMCIA	
ltr		ecn no		dr		date		title	
AM								68 POS EJECTOR HEADER ASSY FOR 5.0V APPLICATION	
		angles		linear				dwg no	
		±2'		0.X±0.3 0.XX±0.13 0.XXX±0.051		MM		sheet 7 of 7	
		dr		Mike Zhou		11/21/06		size	
		enr		Mike Zhou		11/21/06		A4	
		chr		David Qin		11/21/06		type	
		appd		Jack Wang		11/21/06		CUSTOMER Drawing	
sheet		revision							
index		sheet							