

THIS DRAWING AND THE SUBJECT MATTER SHOWN THEREON ARE CONFIDENTIAL AND THE PROPERTY OF BEL/STEWART/TRP CONNECTOR AND SHALL NOT BE REPRODUCED, COPIED, OR USED IN ANY MANNER WITHOUT THE WRITTEN CONSENT OF TRP CONNECTOR.

PRODUCT MAY BE PROTECTED BY ONE OR MORE OF THE FOLLOWING US PATENTS:
 5736910 5939955 6425781 6428361 6554638 6840817 7123117
 7429195 7717749 7808751 6217391 6149050 7924130

REVISIONS				
P	LTN	DESCRIPTION	DATE	OWN APVD
2		SEE LAST SHEET	14JAN2015	RL TY

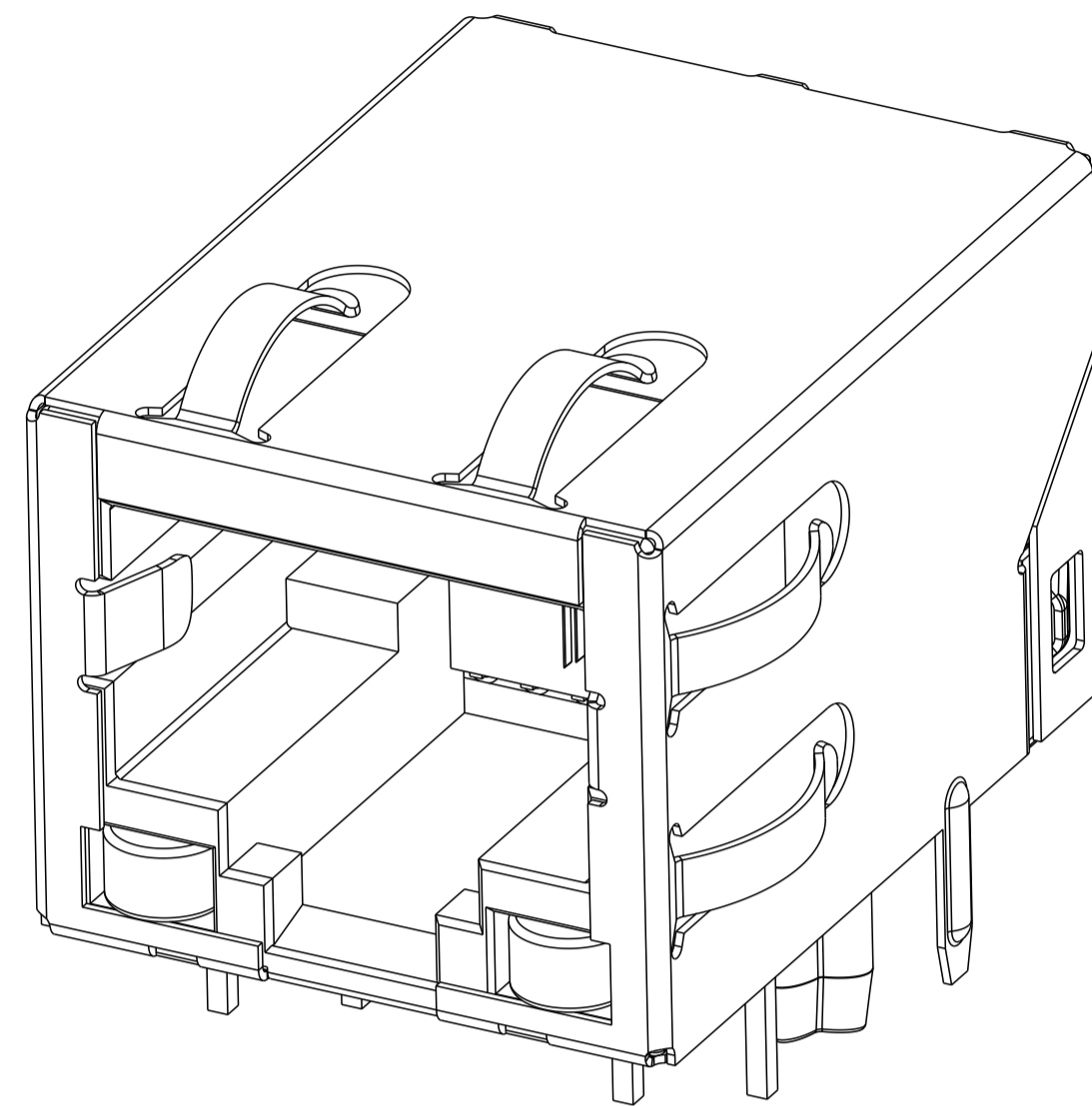
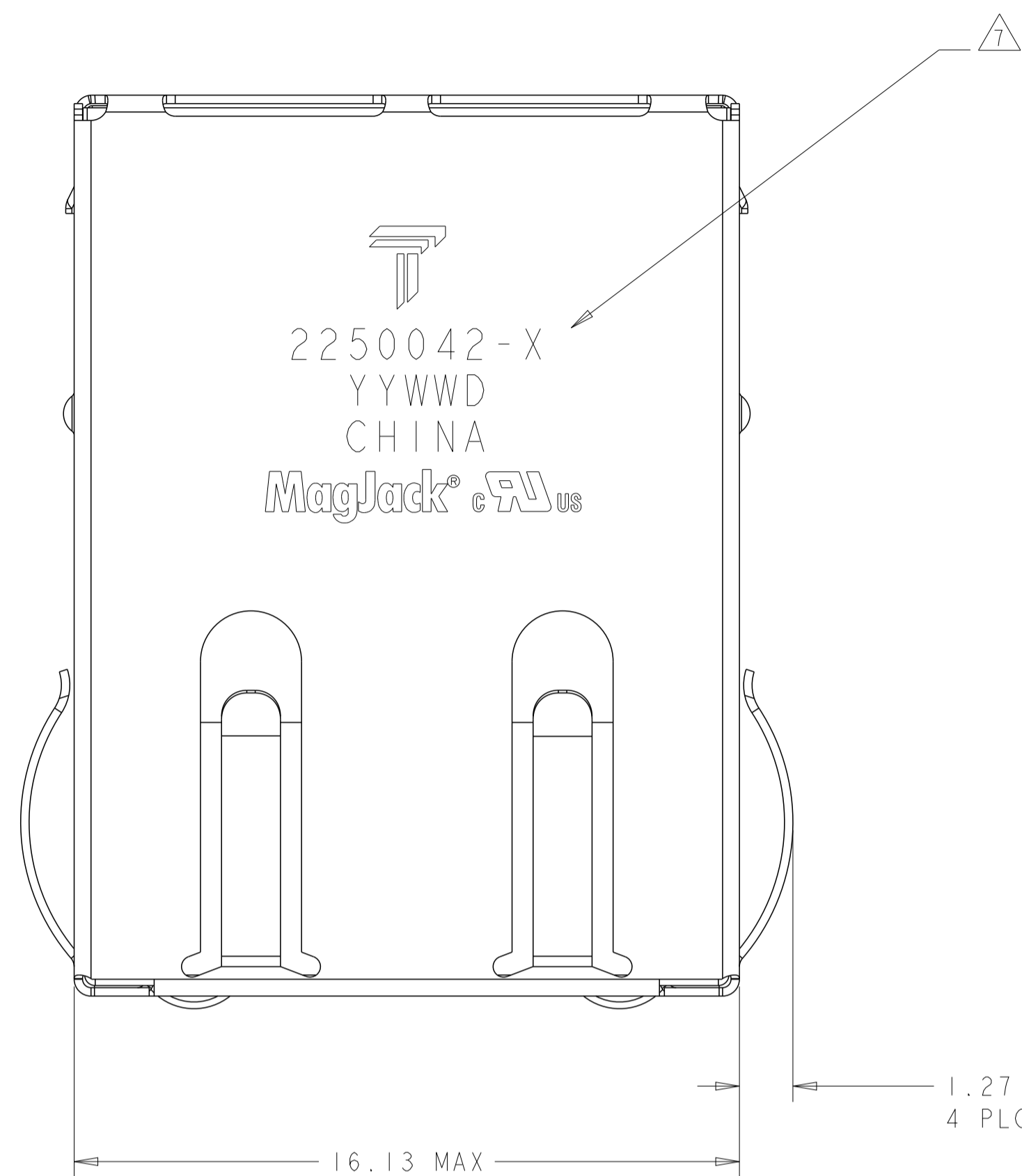

1. MATERIALS
- HOUSING: THERMOPLASTIC, FLAMMABILITY RATING UL 94V-0.
 - SHIELD: BRASS 0.20mm THICK, PREPLATED WITH 0.76um MIN SEMI-BRIGHT NICKEL. SOLDER TABS POST DIPPED WITH 2.54um MIN SAC SOLDER.
 - CONTACTS: PHOSPHOR BRONZE 0.46mm X 0.30mm, PHOSPHOR BRONZE, 1.27um MIN NICKEL UNDERPLATE, WITH 1.27um MIN GOLD PLATING AT MATING INTERFACE AND 2.54um MIN MATTE TIN ON SOLDER TAILS.
 - SOLDER TAILS: 0.25mm THICK, PHOSPHOR BRONZE, 1.27um MIN OVERALL NICKEL UNDERPLATE, 3um TIN PLATE
 - LIGHT EMITTING DIODE (LED): DIFFUSED EPOXY LENS, 0.5mm X 0.5mm CARBON STEEL WIREFRAME LEADS PREPLATED WITH 2.03um MIN. SILVER PLATE OVER 1.02um MIN. NICKEL OVER 1.02um MIN. COPPER UNDERPLATE; LEADS POST-PLATED WITH 3.05um MIN. MATTE TIN AND/OR SAC SOLDER DIP OR PURE TIN SOLDER DIP

2. RJ45 JACK CAVITY CONFORMS TO FCC RULES AND REGULATIONS PART 68 SUB PART F.

3. MAGNETICS
- APPLICATION: 10/100 BASE-T
 - IMPEDANCE: 100 OHMS
 - TURNS RATIO (CHIP:CABLE): TX = 1:1, RX = 1:1
 - OPEN CIRCUIT INDUCTANCE (OCL): 350uH MIN @100kHz, 0.1VRMS, 8mADC BIAS FROM 0°C TO +70°C, TX AND RX
 - PERFORMANCE @ 25°C:
 - INSERTION LOSS (IL): 1.1dB MAX FROM 0.5MHz TO 100MHz
 - RETURN LOSS (RL): 18dB MIN FROM 0.5MHz TO 30MHz
 - 18-20LOG(f/30)dB MIN FROM 30.1MHz TO 60MHz
 - 12dB MIN FROM 60.1MHz TO 80MHz
 - CROSSTALK ATTENUATION: 35dB MIN FROM 0.5MHz TO 40MHz
 - 33-20LOG(f/50)dB MIN FROM 40.1MHz TO 100MHz
 - COMMON MODE REJECTION RATIO (CMRR): 30dB MIN FROM 0.5MHz TO 100MHz
 - ISOLATION VOLTAGE: 2250VDC FOR 60 SECONDS WITH A RISE TIME OF 500 V/SEC

4. OPERATING TEMPERATURE: FROM 0°C TO +70°C.

5. INDICATED MAGNETIC CONNECTIONS ARE SYMMETRICAL TO SUPPORT AUTO-MDI/MDIX.

6. THE 250 OHM LED RESISTORS ARE OPTIONAL, PLEASE SEE CHART FOR PRESENCE OR ABSENCE OF RESISTORS.
 IF LEADS WITHOUT 250 OHM RESISTORS. LEADS ARE DRIVEN WITH CONSTANT CURRENT AT APPROX 20mA
 LED COLOR: DOMINATE WAVELENGTH (λD): GREEN 568 nm TYP. AT IF = 20mA
 FORWARD VOLTAGE (VF): GREEN 2.2V TYP. @ IF = 20mA
 DOMINATE WAVELENGTH (λD): YELLOW 588 nm TYP. AT IF = 20mA
 FORWARD VOLTAGE (VF): YELLOW 2.1V TYP. @ IF = 20mA
 IF LEADS WITH BUIL-IN 250 OHM RESISTORS. LEADS ARE DRIVEN WITH 5V VOLTAGE AND THE MAX OPERATING CURRENT IS 20mA
 LED COLOR: DOMINATE WAVELENGTH (λD): GREEN 568 nm TYP. @ VF=5V
 FORWARD CURRENT (IF): GREEN 12mA TYP @ VF = 5V
 DOMINATE WAVELENGTH (λD): YELLOW 588 nm TYP. @ VF=5V
 FORWARD CURRENT (IF): YELLOW 13mA TYP @ VF = 5V

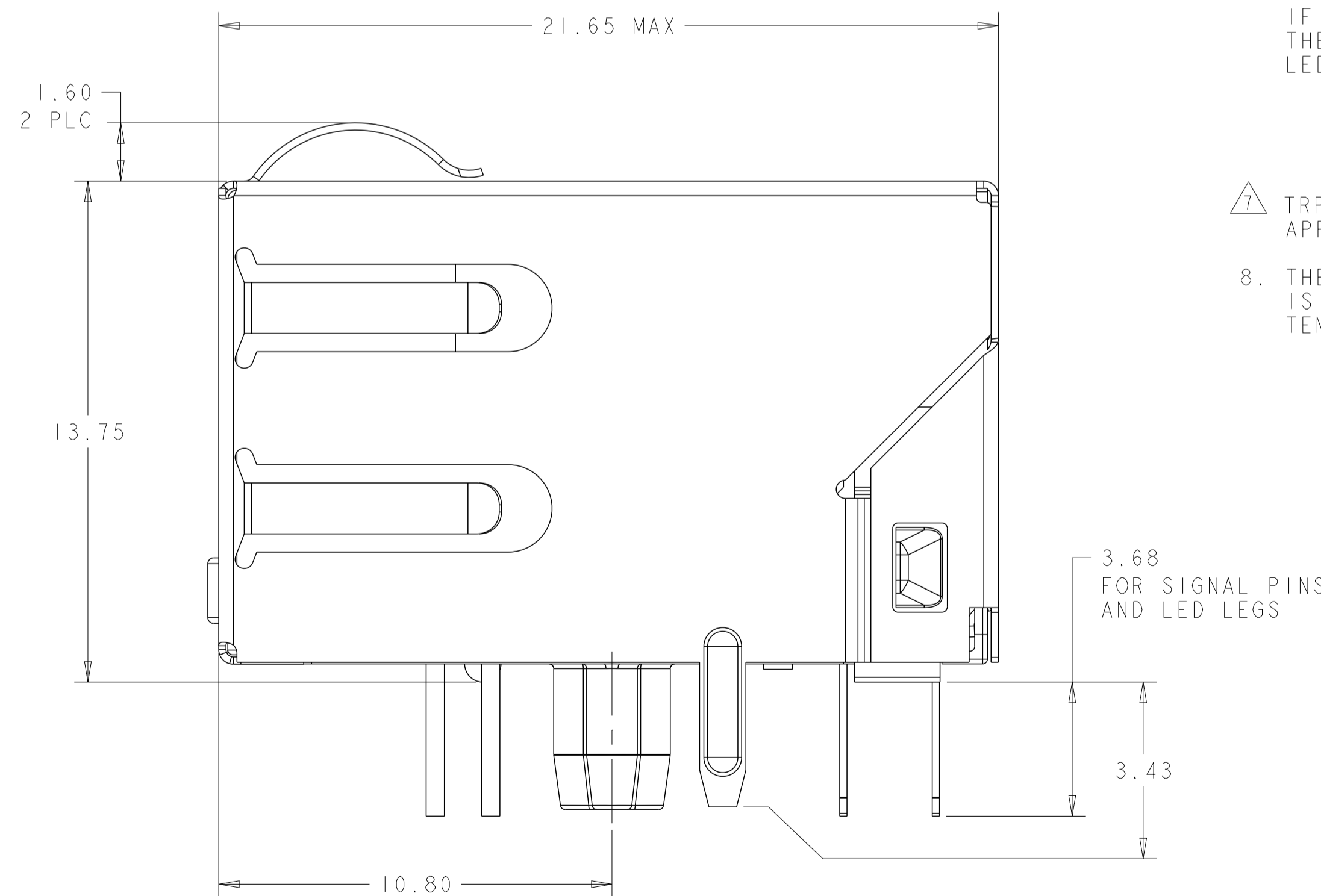
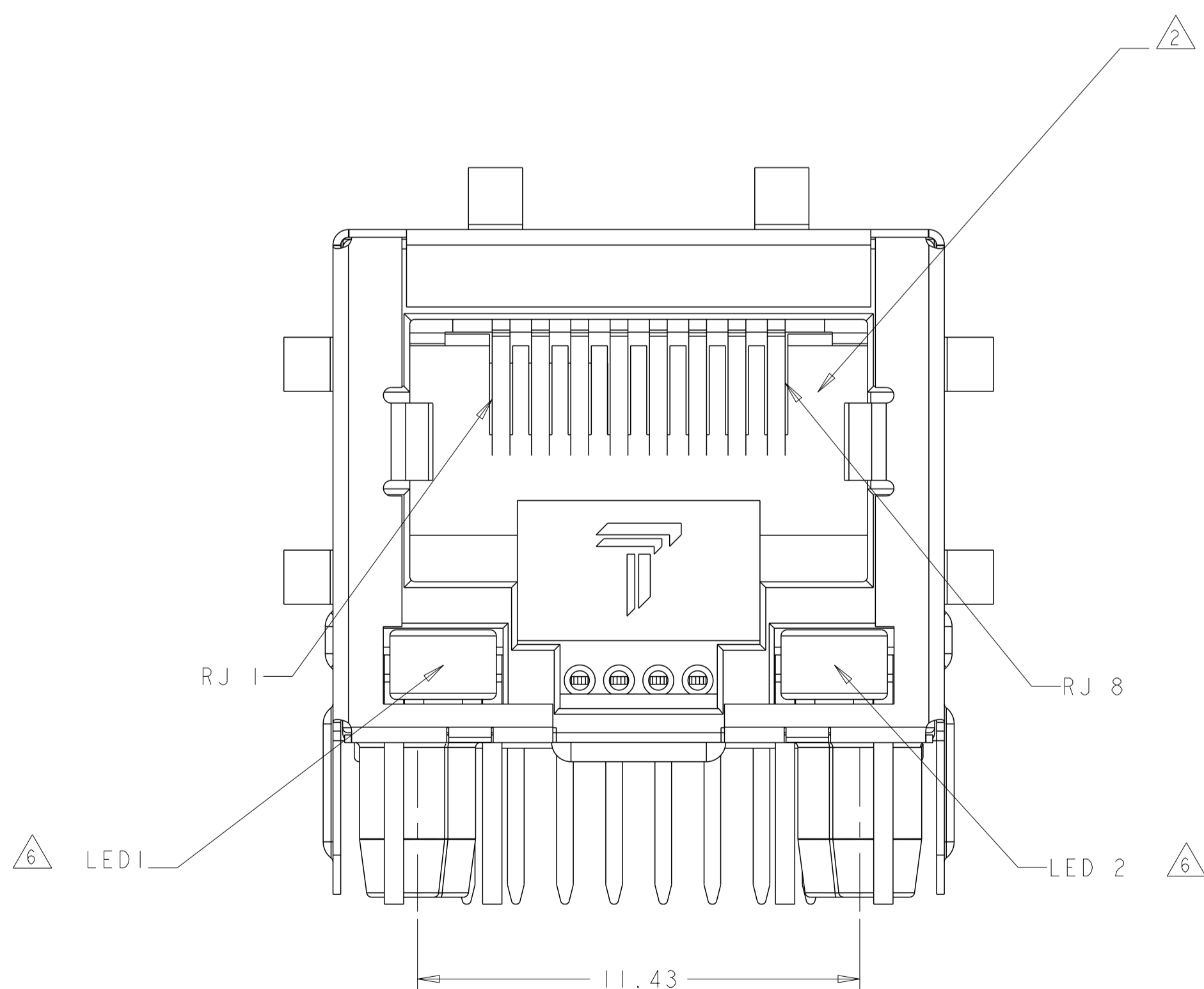

7. TRP CONNECTOR LOGO, PART NUMBER, DATE CODE, COUNTRY OF ORIGIN AND AGENCY APPROVAL MARKING IN APPROXIMATE LOCATION SHOWN.

8. THESE PARTS ARE RECOMMENDED FOR WAVE SOLDERING PROCESS, PREHEAT TEMPERATURE IS 120°C TO 160°C, 120 SECONDS TO 180 SECONDS, PEAK WAVE SOLDERING TEMPERATURE IS 260°C MAX, 10 SECONDS MAX.



GREEN	YES	YELLOW	YES	2250042-2
GREEN	NO	YELLOW	NO	2250042-1
9 10	250 OHMS RESISTOR	11 12	250 OHMS RESISTOR	PART NUMBER
LED 1		LED 2		

THIS DRAWING IS A CONTROLLED DOCUMENT.		OWN: ROY LIU 05JUN2013	 trp CONNECTOR a bel group	DONGGUAN CHINA
DIMENSIONS: mm		CHK: TOWER YU/FRANK LIU 05JUN2013		
TOLERANCES UNLESS OTHERWISE SPECIFIED:		APVD: TONY YUAN 05JUN2013	MODEL NAME: MAGJACK	
0 PLC ±0.25 1 PLC ±0.25 2 PLC ±0.25 3 PLC ±0.25 4 PLC ± ANGLES ± APPLICATION SPEC ±		DESC: 1X1 314P10 10/100 TAB DOWN W/ LED		RESTRICTED TO
PRODUCT SPEC: 108-104004		SIZE: A1	CAGE CODE: C=2250042	DRAWING NO: 2250042
CUSTOMER DRAWING		SCALE: 4:1	SHEET: 1	OF: 3
			REV: 2	

314P10 10/100 BASE-T CIRCUIT  

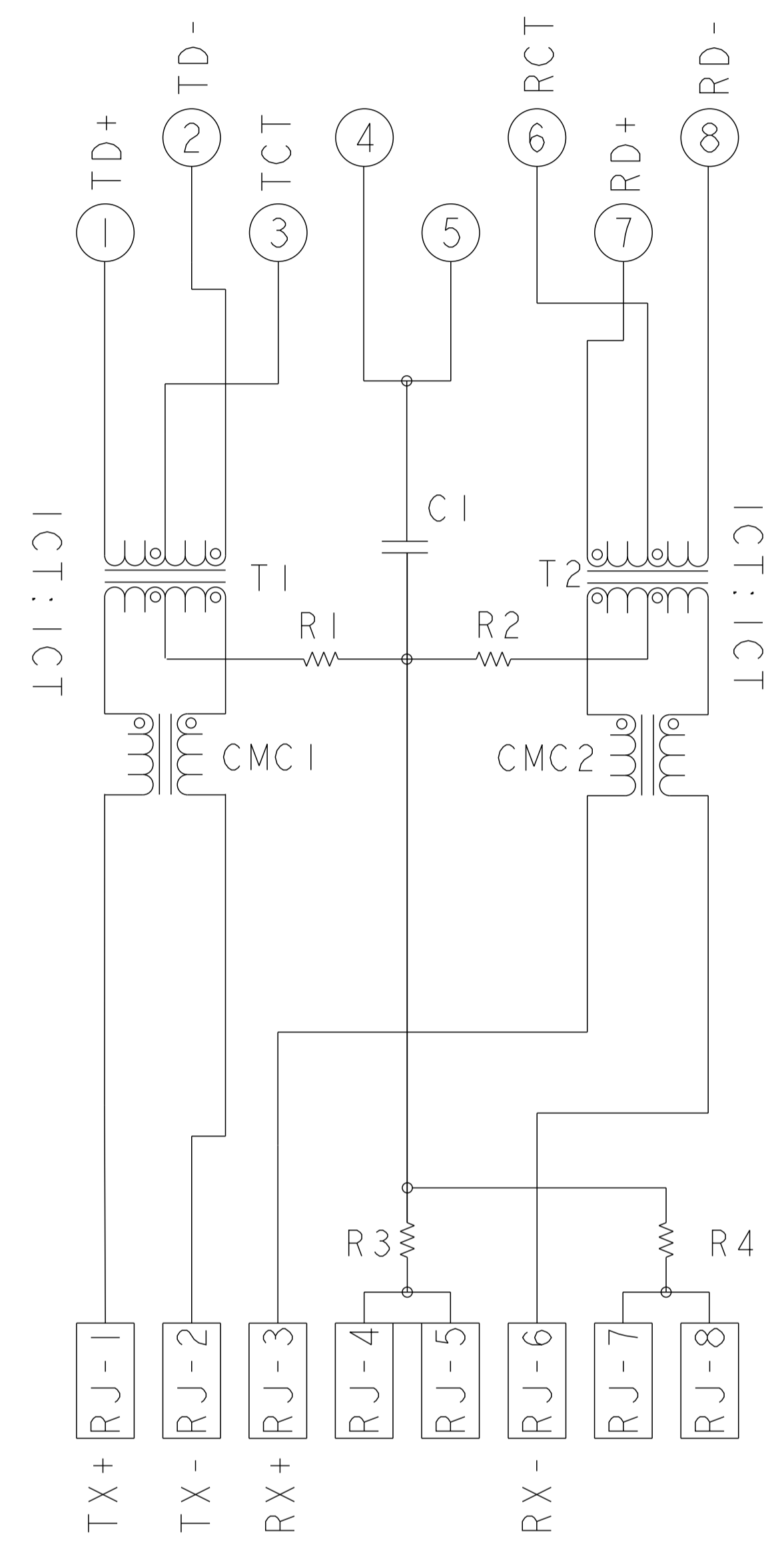
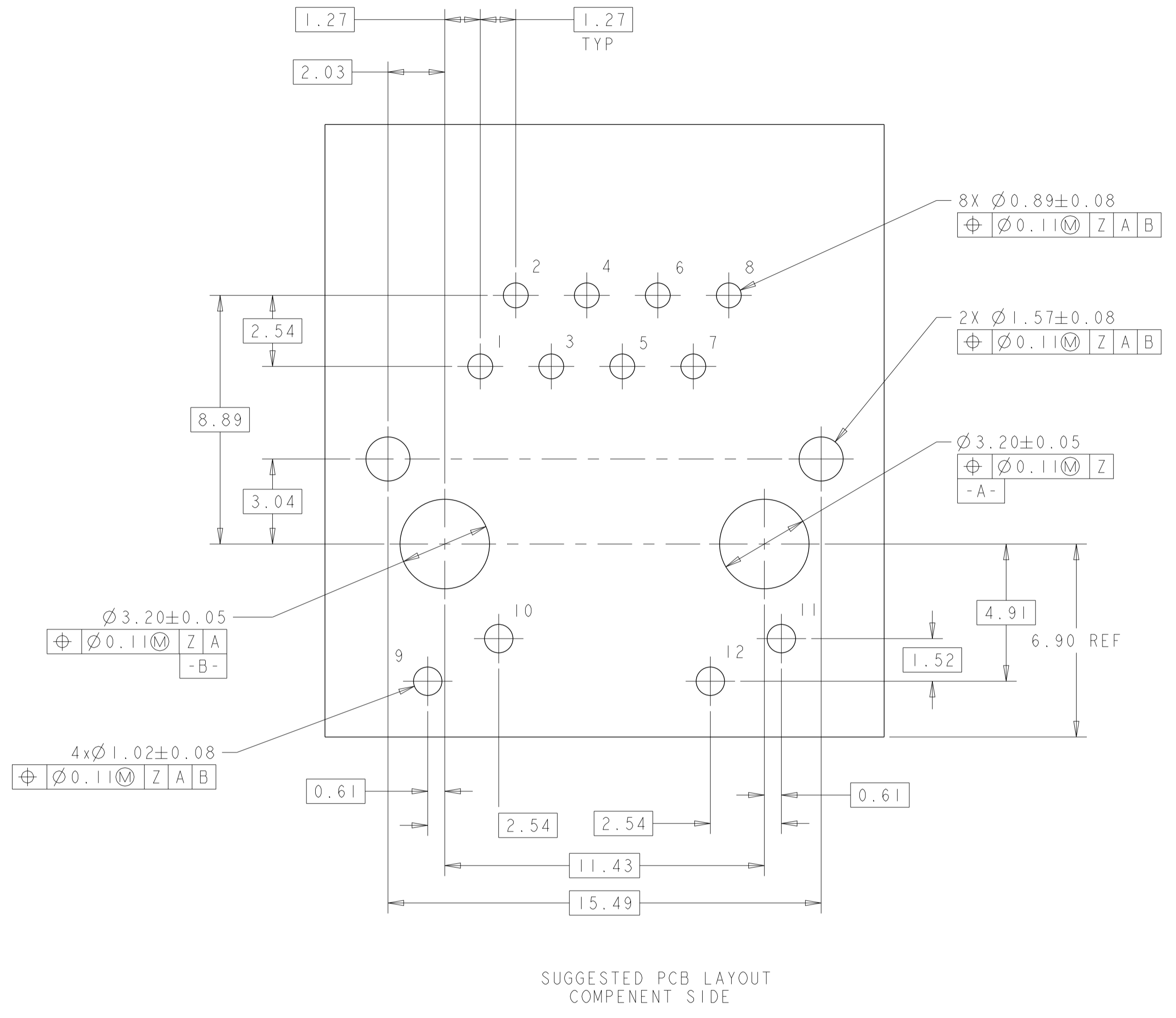

1. C1 = 1000pF, 2kV, CAPACITORS
2. R1-R4 = 75 Ohms, RESISTORS

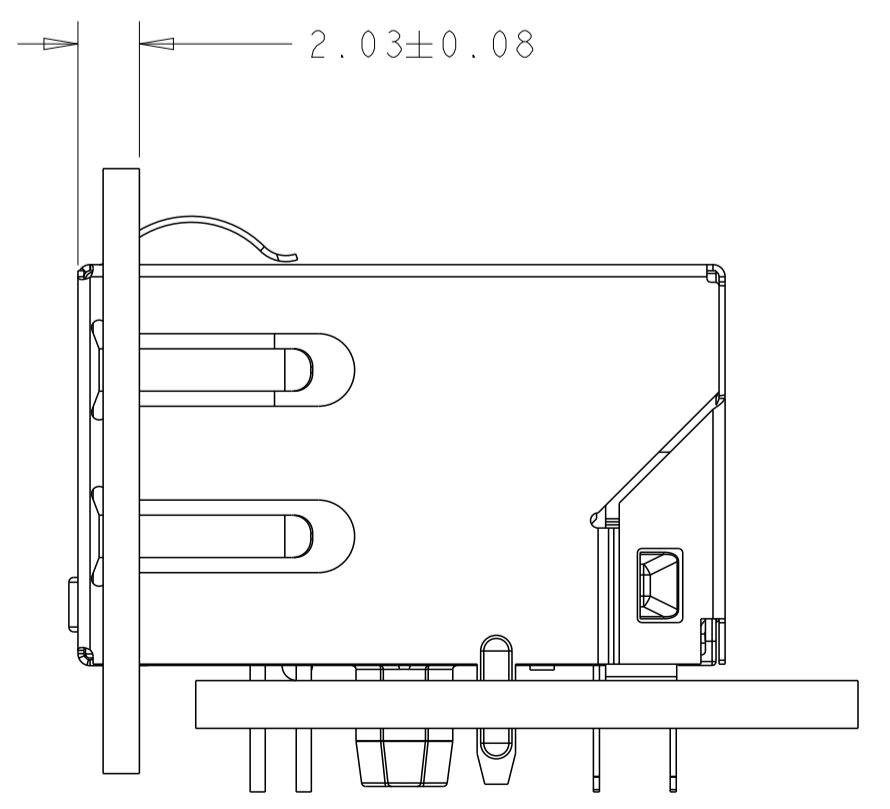
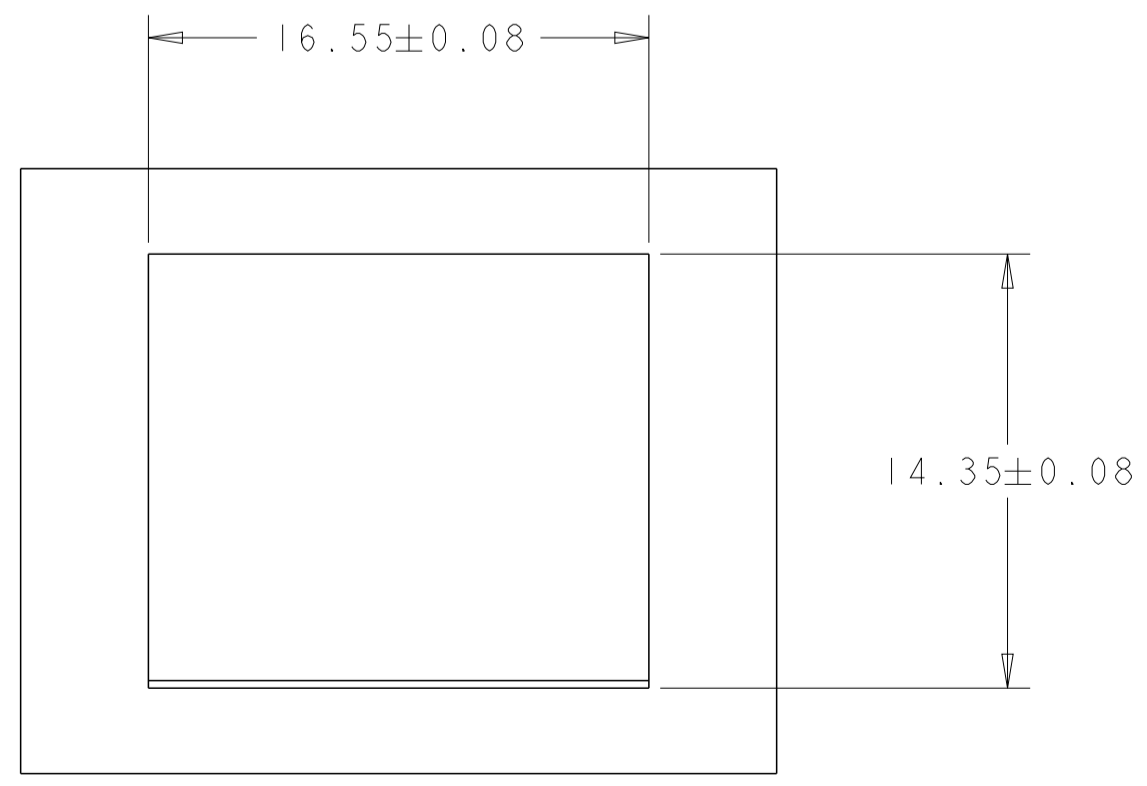

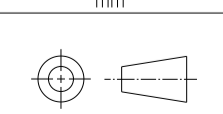
THIS DRAWING IS A CONTROLLED DOCUMENT.		OWN ROY LIU 05JUN2013	 trp CONNECTOR a bel group DONGGUAN CHINA
DIMENSIONS: mm		CHK TOWER YU/FRANK LIU 05JUN2013	
		APP'D TONY YUAN 05JUN2013	
TOLERANCES UNLESS OTHERWISE SPECIFIED:		MODEL NAME MAGJACK	
0 PLC ±0.25 1 PLC ±0.25 2 PLC ±0.25 3 PLC ±0.25 4 PLC ± ANGLES ± APPLICATION SPEC ±		DESC 1X1 314P10 10/100 TAB DOWN W/ LED	
PRODUCT SPEC 108-104004		SIZE A1	
		CAGE CODE C=2250042	
		RESTRICTED TO	
		CUSTOMER DRAWING	
		SCALE 4:1 SHEET 2 OF 3 REV 2	

C_2250042					STOCK DISPOSITION			
REVISION HISTORY					A: CONTINUE AS IS	D: USE OLD FIRST		
					B: REWORK	E: PARTS TO CONFORM		
					C: SCRAP	F: OTHER		
DATE	REV	CHANGES	REASON	APPROVAL	INVENTORY (A,B,C,D,E,F)	WORK IN PROCESS (A,B,C,F)	SUPPLIER ORDERS (A,E,F)	OPEN CUST ORDERS (A,E,F)
05JUN2013	1	-	INITIAL RELEASE	TONY YUAN	-	-	-	-
14JAN2015	2	EC-1411035 COMPANY LOGO CHANGE	MARKET REQUIREMENT	TONY YUAN	-	-	-	-

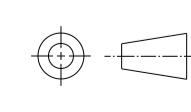
THIS DRAWING IS A CONTROLLED DOCUMENT.		OWN ROY LIU	05JUN2013	 trp CONNECTOR <small>a bel group</small>	DONGGUAN CHINA
DIMENSIONS: mm		CHK TOWER YU/FRANK LIU	05JUN2013		DESC 1X1 314P10 10/100 TAB DOWN W/ LED
		APVD TONY YUAN	05JUN2013		SIZE A1
0 PLC ±0.25 1 PLC ±0.25 2 PLC ±0.25 3 PLC ± 4 PLC ± ANGLES ± APPLICATION SPEC ±		MODEL NAME MAGJACK SINGLE Non-PoE		DRAWING NO C=2250042	RESTRICTED TO -
PRODUCT SPEC 108-104004		CUSTOMER DRAWING		SCALE 4:1	SHEET 3 OF 3
				REV 2	