

NMA 1 SERIES

Non-magnetic Trimmer Capacitors

Part Number	Capacitance (pF)		Q (Min)	DC Working Voltage	DC Withstanding Voltage	Dielectric	Fig.	"A" Dim. $\pm .016$	"B" Dim. $\pm .016$
	From Below	To Above	100 MHz.						
NMA1F4HV	0.45	4	4000	1000	2000	PTFE	4	0.39	0.25
NMA1J4HV	0.45	4	4000	1000	2000	PTFE	1	0.14	0.26
NMA1M4HV	0.45	4	4000	1000	2000	PTFE	5	0.40	0.26
NMA1P4HV	0.45	4	4000	1000	2000	PTFE	2	0.14	0.26
NMA1T4HV	0.45	4	4000	1000	2000	PTFE	3	0.15	0.24
NMA1F8HV	0.5	8	3000	500	1000	PTFE	4	0.39	0.25
NMA1J8HV	0.5	8	3000	500	1000	PTFE	1	0.14	0.26
NMA1M8HV	0.5	8	3000	500	1000	PTFE	5	0.40	0.26
NMA1P8HV	0.5	8	3000	500	1000	PTFE	2	0.14	0.26
NMA1T8HV	0.5	8	3000	500	1000	PTFE	3	0.15	0.24
NMA1F12HV	0.6	12	2000	500	1000	PTFE	4	0.50	0.30
NMA1J12HV	0.6	12	2000	500	1000	PTFE	1	0.20	0.30
NMA1M12HV	0.6	12	2000	500	1000	PTFE	5	0.50	0.30
NMA1P12HV	0.6	12	2000	500	1000	PTFE	2	0.20	0.30
NMA1T12HV	0.6	12	2000	500	1000	PTFE	3	0.21	0.29

FIG. 1

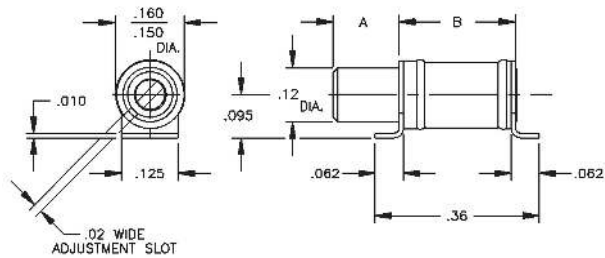

FIG. 4

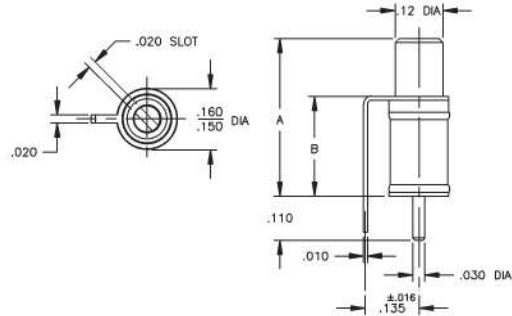

FIG. 2

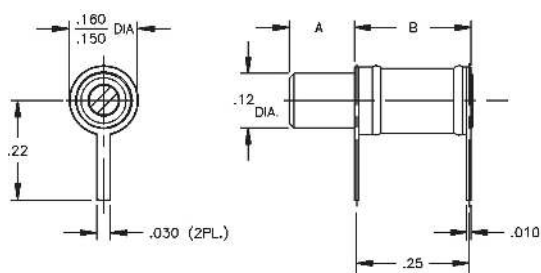

FIG. 5

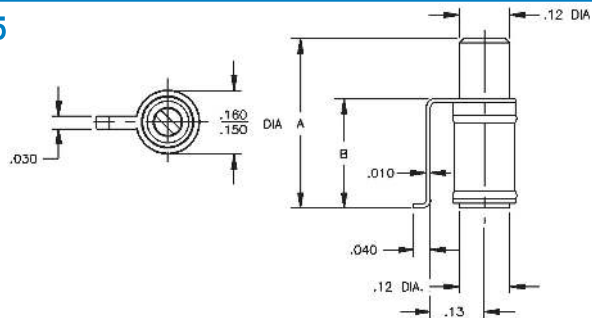
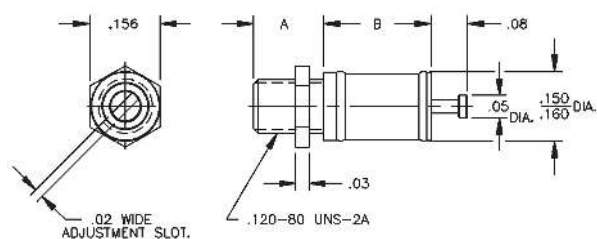

FIG. 3



IN	MM	IN	MM	IN	MM	IN	MM
0.010	0.254	0.070	1.778	0.150	3.810	0.278	7.061
0.015	0.381	0.080	2.032	0.156	3.962	0.290	7.366
0.016	0.406	0.095	2.413	0.160	4.064	0.320	8.128
0.020	0.508	0.100	2.540	0.165	4.191	0.325	8.255
0.025	0.635	0.110	2.794	0.210	5.334	0.360	9.144
0.030	0.762	0.120	3.048	0.220	5.588	0.390	9.906
0.036	0.914	0.125	3.175	0.225	5.715	0.400	10.160
0.040	1.016	0.130	3.302	0.240	6.096		
0.050	1.270	0.125	3.429	0.250	6.350		
0.062	1.575	0.140	3.556	0.260	6.604		