

REVISIONS					
P	LTR	DESCRIPTION	DATE	DMN	APVD
E		REV PER ECO 19-019228	4-16-20	CT	DM

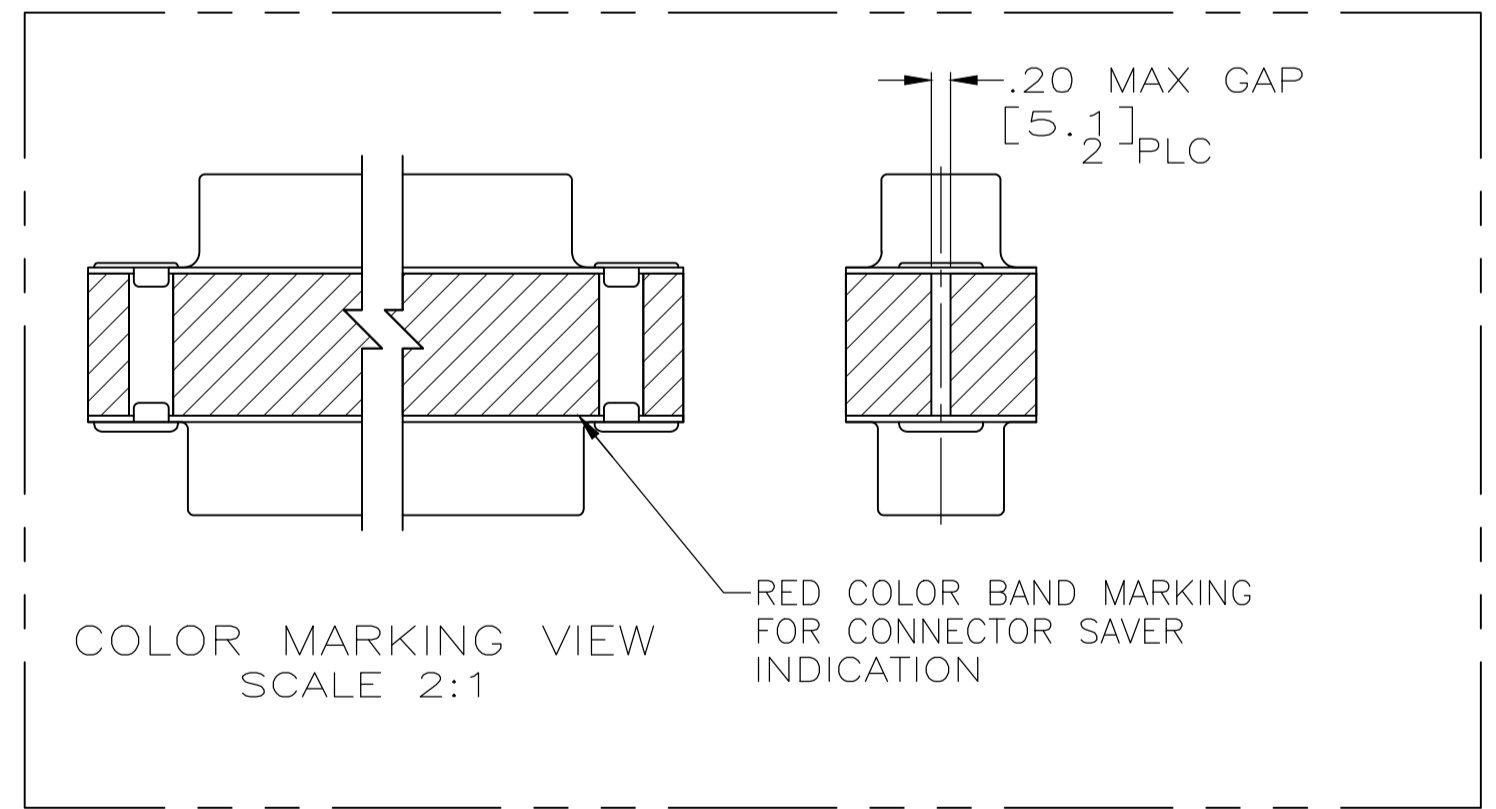
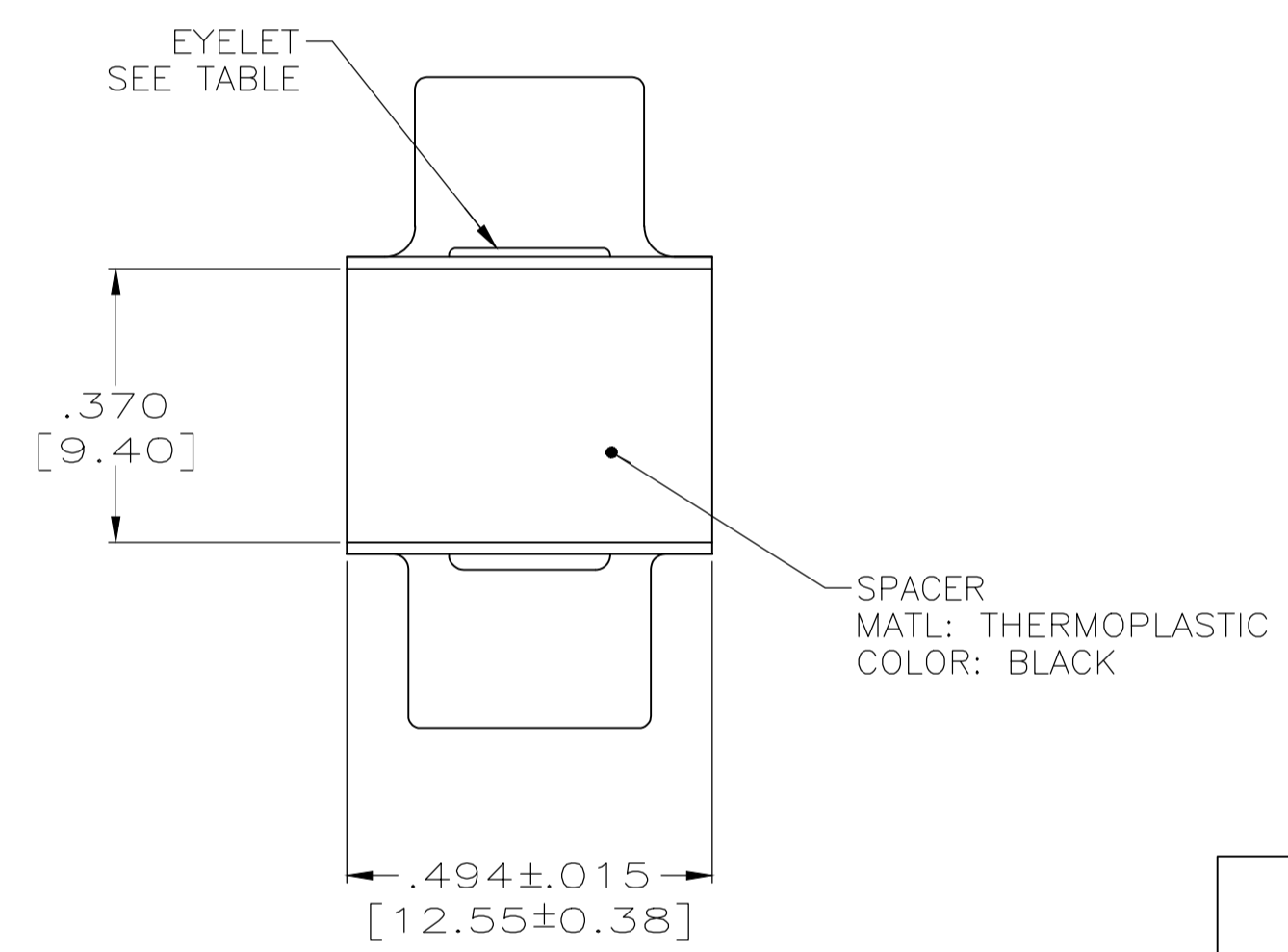
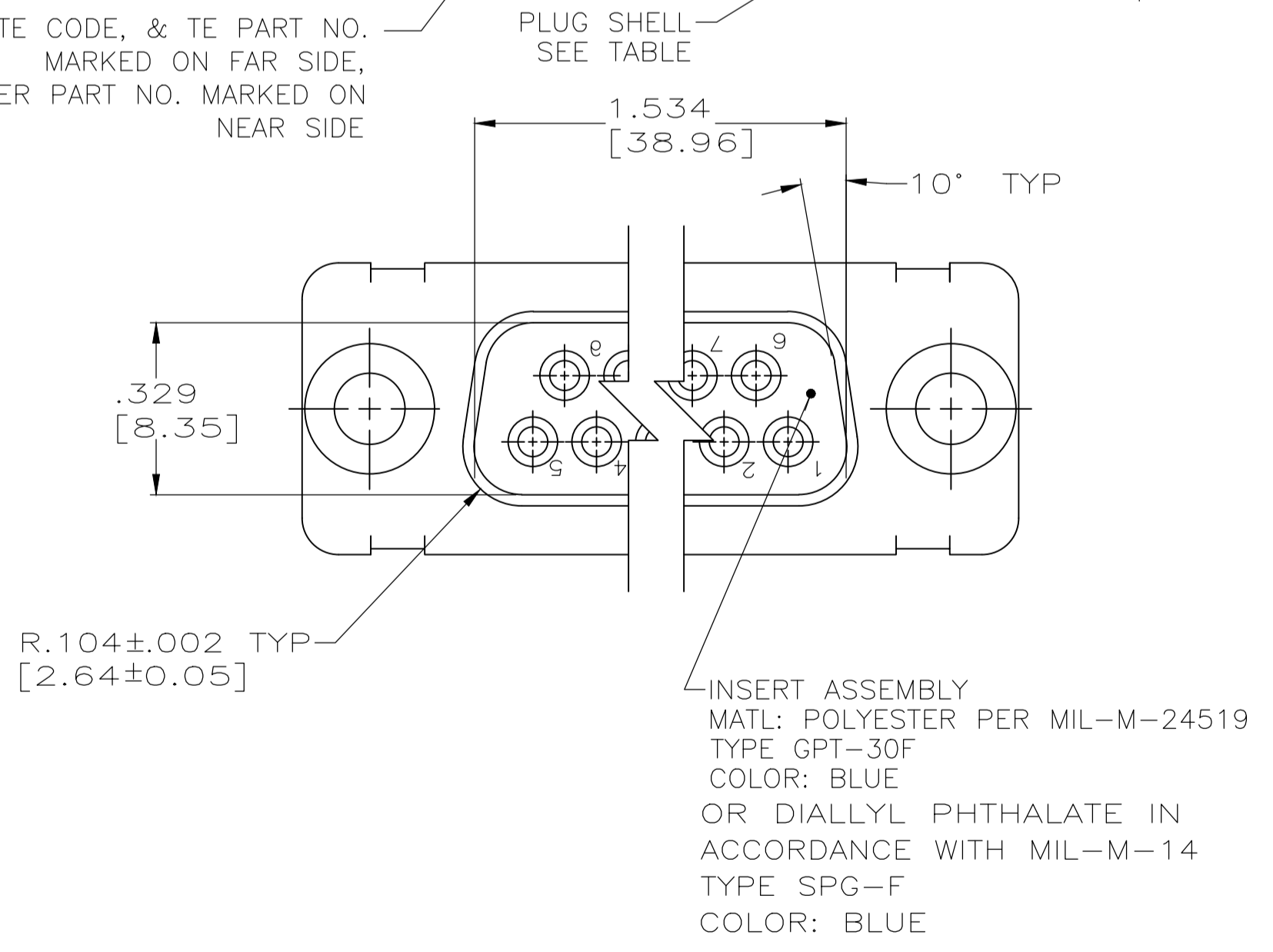
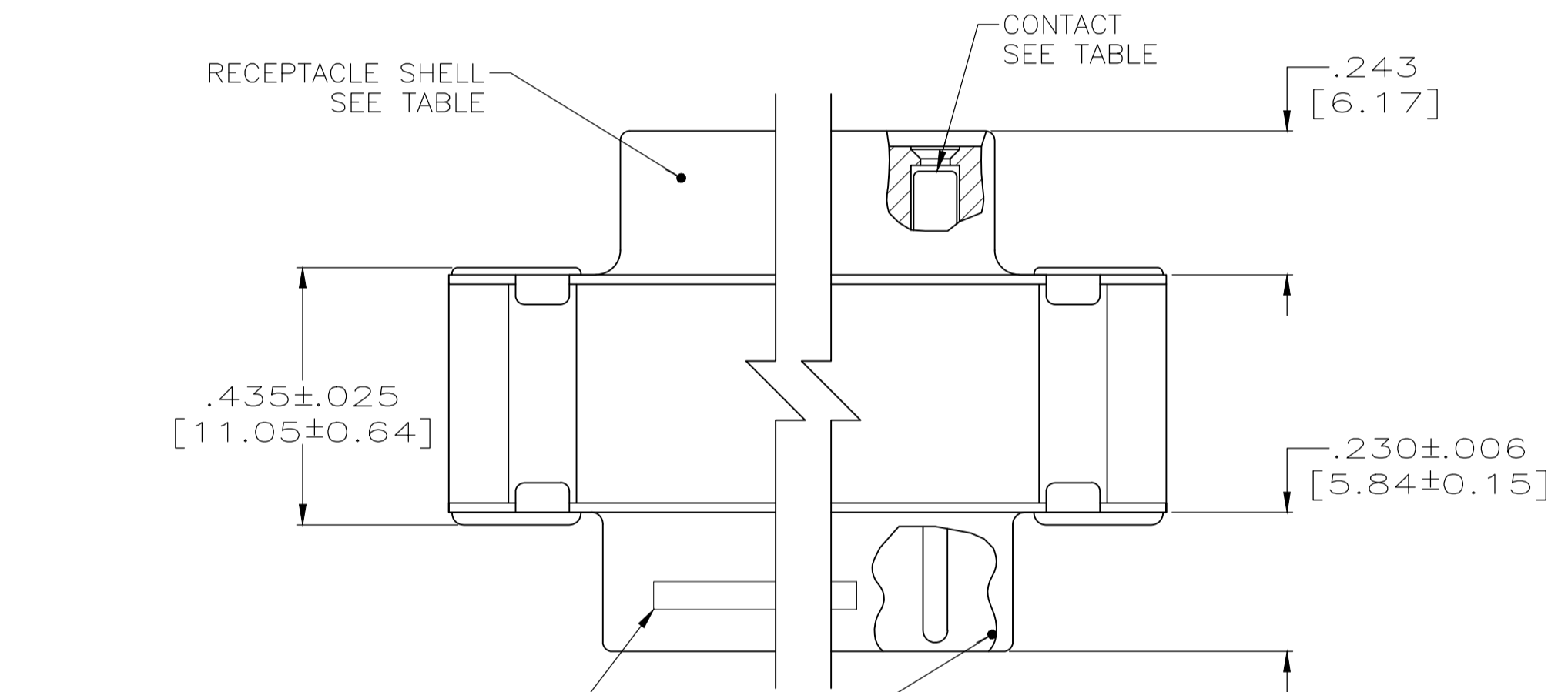
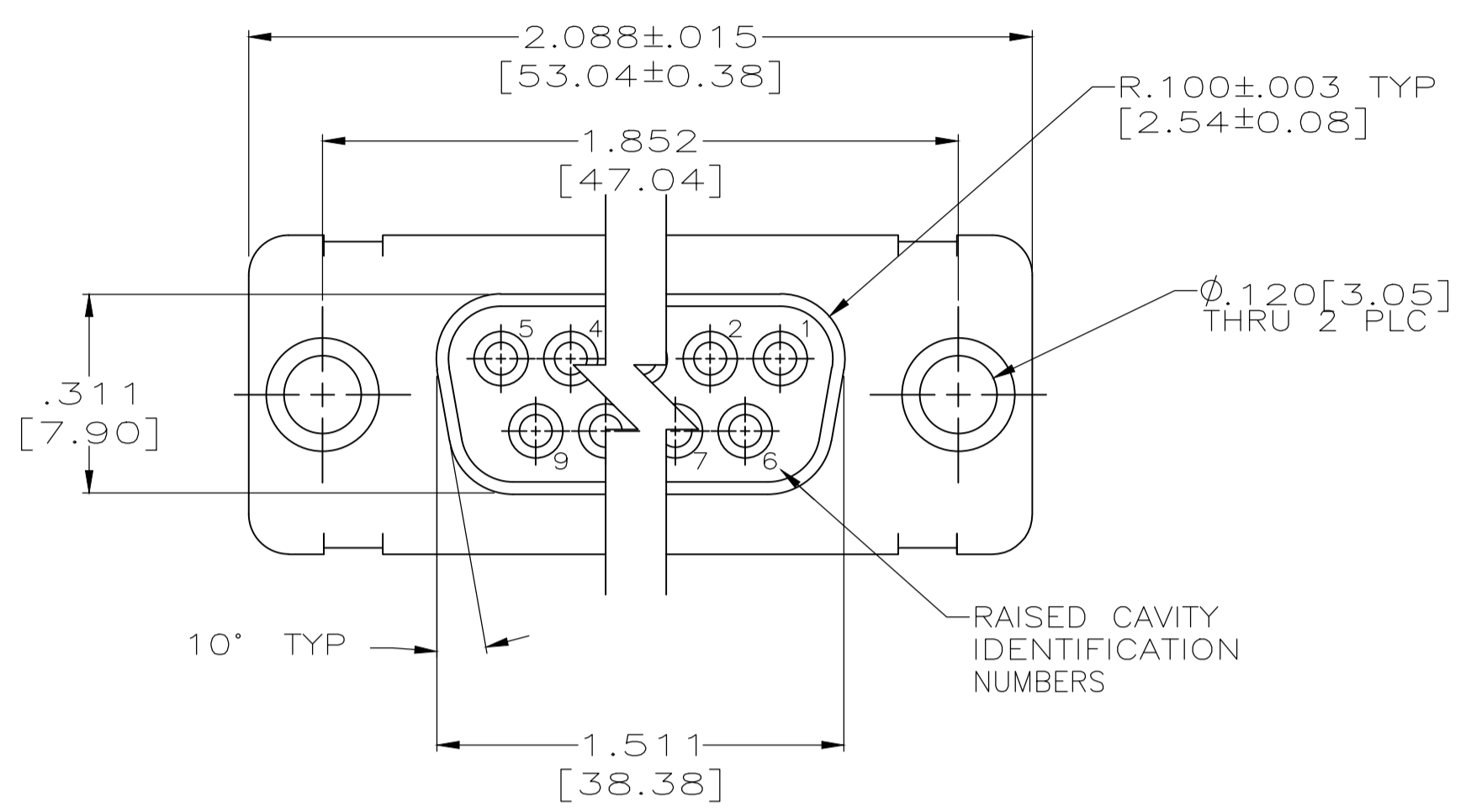

- CONTACTS INCLUDED IN ASSEMBLY.
- CONTACT
 BODY MATL: BERYLLIUM COPPER PER ASTM-B-197.
 BODY FINISH: PLATED GOLD, .000050 MIN THK PER MIL-G-45204 OVER NICKEL, .000050 MIN THK PER QQ-N-290.
 HOOD MATL: STAINLESS STEEL PER ASTM-A-167.
 HOOD FINISH: PASSIVATED PER ASTM-A-380.
- MATL: BRASS PER ASTM-B-36.
- FINISH: PLATED GOLD, .000050 MIN THK PER MIL-G-45204 OVER COPPER, .000100 MIN THK PER MIL-C-14550.

③ ④	③ ④	②	4U884 SOCN R10002677-0003	1218305-2
③ ④	③ ④	②	(1J02-003)	1218305-1
EYELET	SHELLS	CONTACT	CUSTOMER P/N	PART NO.

THIS DRAWING IS A CONTROLLED DOCUMENT.		DIN T. THOMPSON 19AUG98		TE Connectivity	
DIMENSIONS: INCHES		TOLERANCES UNLESS OTHERWISE SPECIFIED:		NAME	
0 PLC ± - 1 PLC ± - 2 PLC ± - 3 PLC ± .005(0.13) 4 PLC ± - ANGLES ± -		APVD J. NORTON 19AUG98 PRODUCT SPEC APPLICATION SPEC WEIGHT 0.000000 CUSTOMER DRAWING		AMPLITE CONNECTOR SAVER SERIES 109, SIZE 3, 25 POS NON-REMOVABLE CONTACTS SIZE CAGE CODE DRAWING NO A1 00779 C=1218305 SCALE 4:1 SHEET 1 OF 1 REV E	